

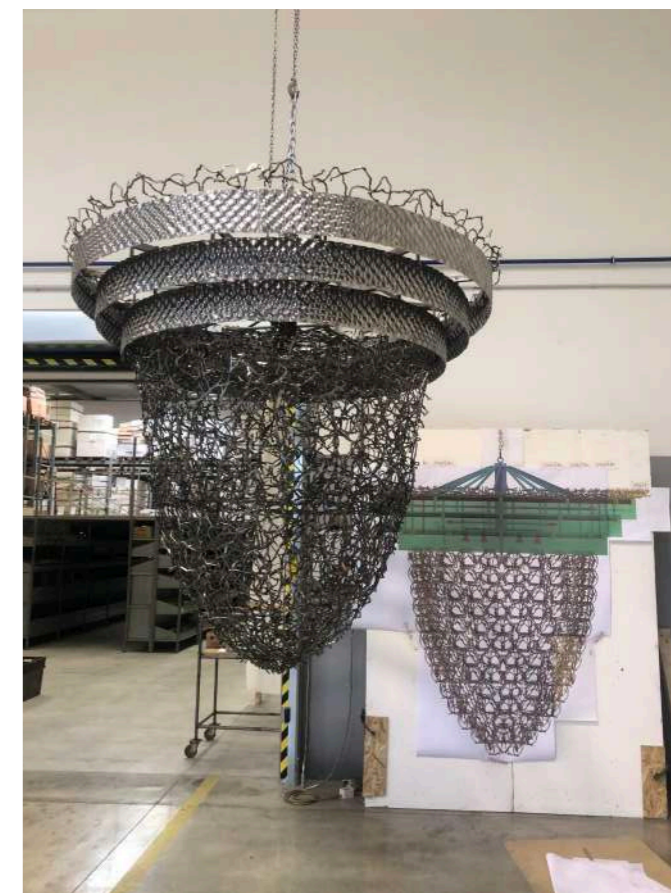

ITALIAN DESIGN LIGHTING

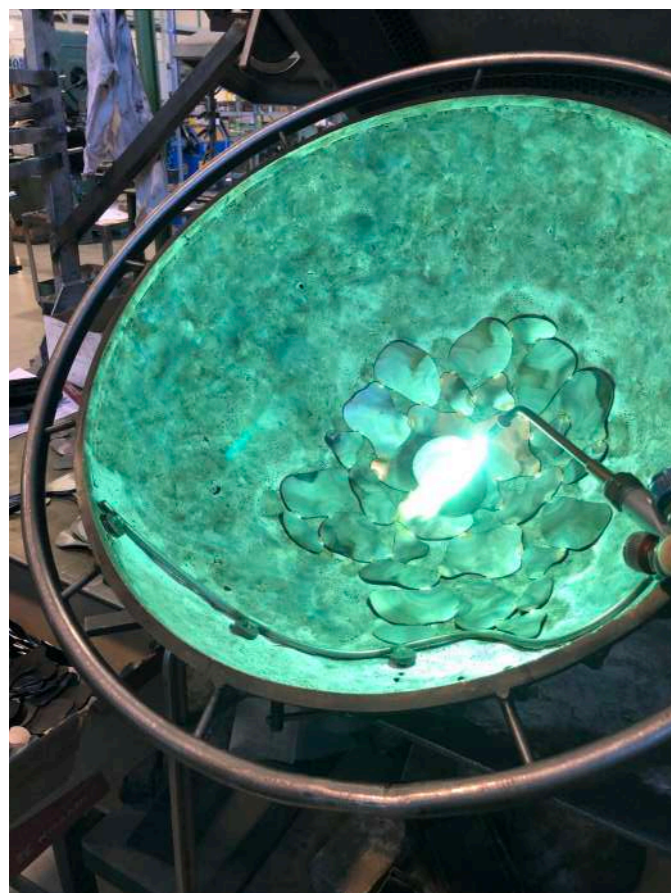

## ABOUT

LA FABBRICA IDL (ITALIAN DESIGN LIGHTING) È STATA FONDATA NEL 1987 A FANZOLO DI VEDELAGO DA FELTRIN LINO E ANTONIO PIVA. CON UNA PRODUZIONE PROPRIA, L'AZIENDA PROGETTA LAMPADE DAL DESIGN ESCLUSIVO, DI QUASI OGNI FORMA E DIMENSIONE, CREANDO ANCHE PRODOTTI SU MISURA.

IL PUNTO DI FORZA DELLA FABBRICA È L'UFFICIO TECNICO, CHE REALIZZA DEI PROGETTI PIÙ COMPLESSI, CHE, GRAZIE ALLA PRODUZIONE MODERNA E AI MODERNI METODI DI LAVORAZIONE DEI METALLI, VENGONO IMPLEMENTATI CON PARTICOLARE ATTENZIONE ALLA REALIZZAZIONE DEI DETTAGLI.

IDL È IL MADE IN ITALY INDISCUSSO PER QUALITÀ E DESIGN ORIGINALE.

LA DIREZIONE ARTISTICA AFFIDATA INIZIALMENTE AD ANTONIO PIVA E AL NIPOTE CRISTIAN FELTRIN, È STATA COSTANTEMENTE ALLA RICERCA DI NUOVE IDEE. DAL 2012, DOPO L'IMPROVVISA SCOMPARSA DEL SOCIO FONDATORE ANTONIO PIVA, CRISTIAN È DIVENTATO IL SOLO DESIGNER. LA COSTANTE RICERCA DI NUOVE IDEE E DI NUOVI MATERIALI È LA LINEA GUIDA FONDAMENTALE DI CRISTIAN E LA RISPOSTA ALLA RICHIESTA DI PRODOTTI UNICI.

THE FACTORY IDL (ITALIAN DESIGN LIGHTING) WAS ESTABLISHED IN 1987 IN FANZOLO DI VEDELAGO BY FELTRIN LINO AND ANTONIO PIVA. HAVING OWN PRODUCTION THE COMPANY DESIGN LAMPS OF EXCLUSIVE DESIGN, OF ALMOST ANY SHAPE AND SIZE, CREATING ALSO CUSTOM MADE PRODUCTS.

THE STRENGTH OF THE FACTORY IS THE TECHNICAL DEPARTMENT, MAKING THE MOST COMPLEX PROJECTS, WHICH, THANKS TO MODERN PRODUCTION AND MODERN METHODS OF METAL PROCESSING, ARE BEING IMPLEMENTED WITH PARTICULAR ATTENTION TO THE DETAIL REALIZATION.

IDL IS THE UNDISPUTED MADE IN ITALY FOR QUALITY AND ORIGINAL DESIGN.

THE ART DIRECTION HEADED BY ANTONIO PIVA AND BY HIS NEPHEW CRISTIAN FELTRIN, HAS BEEN CONSTANTLY LOOKING FOR NEW IDEAS. SINCE 2012, AFTER THE SUDDEN DEMISE OF THE FOUNDER ANTONIO PIVA, CRISTIAN HAS BECOME THE MOST IMPORTANT DESIGNER OF THE COMPANY. THE CONSTANT SEARCH FOR NEW IDEAS AND NEW MATERIALS IS THE FUNDAMENTAL GUIDELINE FOR CRISTIAN AND THE ANSWER TO THE DEMAND FOR UNIQUE PRODUCTS.

TUTTI I PRODOTTI DELLA FABBRICA SONO ACCURATAMENTE TESTATI. OGNI PRODOTTO VIENE CONTRASSEGNA TO CON IL MARCHIO "IDL" COME GARANZIA AL 100% CHE OGNI LAMPADA È ORIGINALE, PROGETTATA E PRODOTTA IN ITALIA. L'ALTA QUALITÀ DELLE FINITURE METALLICHE CONSENTE L'UTILIZZO DELLE LAMPADE IN AMBIENTI UMIDI.

LA GAMMA DEI PRODOTTI IDL È VARIA: LE COLLEZIONI DI LAMPADE DAL DESIGN RAFFINATO, CARATTERIZZATO DA LINEE MORBIDE ED ELEGANTI IN CUI OGNI DETTAGLIO È SELEZIONATO CON GUSTO, DA COSTOSE FINITURE IN METALLO, DA DETTAGLI FATTI A MANO, SQUISITO VETRO DI MURANO E COLLEZIONI DI FORME SEMPLICI E RIGOROSE, LINEE PULITE COMBINATE CON RAZIONALITÀ E FUNZIONALITÀ.

GRAZIE A 30 ANNI DI ESPERIENZA E PROFESSIONALITÀ DELLO STAFF TECNICO, IDL PROGETTA, SVILUPPA E REALIZZA APPARECCHI DI ILLUMINAZIONE PERSONALIZZATI. CIRCA LA METÀ DEL VOLUME DI PRODUZIONE DELLA FABBRICA È OCCUPATA DA MODELLI NON STANDARD.

## THE KNOW-HOW

ALL PRODUCTS OF THE FACTORY ARE CAREFULLY TESTED. EACH PRODUCT IS MARKED WITH THE "IDL" TRADEMARK AS A 100% GUARANTEE THAT EACH LAMP IS ORIGINAL, DESIGNED AND MANUFACTURED IN ITALY. HIGH QUALITY OF THE METAL FINISHES ALLOWS THE USE OF THE LAMPS IN WET AREAS.

THE RANGE OF IDL'S PRODUCTS IS VARIOUS: COLLECTION OF LAMPS OF EXQUISITE DESIGN CHARACTERIZED BY SOFT ELEGANT LINES WHERE EVERY DETAIL IS TASTEFULLY SELECTED, BY EXPENSIVE METAL FINISHES, BY HAND-MADE DETAILS, EXQUISITE MURANO GLASS AND COLLECTIONS OF A SIMPLE AND STRICT FORMS, CLEAN LINES COMBINED WITH RATIONALITY AND FUNCTIONALITY.

THANKS TO 30 YEARS OF EXPERIENCE AND PROFESSIONALISM OF THE TECHNICAL STAFF, THE IDL DESIGNS, DEVELOPS AND CREATES CUSTOM - MADE LIGHTING FIXTURES. ABOUT HALF OF THE PRODUCTION VOLUME OF THE FACTORY IS OCCUPIED BY NON-STANDARD MODELS.

# Index



**Acropora**  
page 40-51



**Bamboo**  
page 402-425



**Crystal Blade**  
page 238-251



**Divina**  
page 294-303



**Amalfi**  
page 374-381



**Cesare**  
page 194-199



**Crystal Moon**  
page 272-281



**Eklé**  
page 08-39



**Flower Miu**  
page 58-67



**Miu**  
page 52-57



**Roma**  
page 200-213



**Amalgama**  
page 182-193



**Charme**  
page 304-315



**Crystal Rock**  
page 346-353



**Elite**  
page 100-109



**Groovy**  
page 110-123



**Nuvola**  
page 394-401



**Tribù**  
page 142-151



**Angel**  
page 266-271



**Chrysalis**  
page 152-171



**Crystalline**  
page 214-225



**Flame**  
page 320-331



**Ice rain**  
page 84-99



**Paradise**  
page 252-265



**Vanity**  
page 282-285



**Artic**  
page 68-83



**Corten**  
page 354-373



**Diamante**  
page 226-231



**Floritude**  
page 232-237



**Leaves**  
page 172-181



**Prestige**  
page 332-345



**Weave**  
page 124-141

# Index



**Flower Miu**  
page 58-67



**Miu**  
page 52-57



**Roma**  
page 200-213



**Grace**  
page 316-319



**Ninfea**  
page 286-293



**Stardust**  
page 382-393



**Groovy**  
page 110-123



**Nuvola**  
page 394-401



**Tribù**  
page 142-151



**Ice rain**  
page 84-99



**Paradise**  
page 252-265



**Vanity**  
page 282-285



**Leaves**  
page 172-181



**Prestige**  
page 332-345



**Weave**  
page 124-141



# Eklè

DESIGN *Cristian Feltrin*

Modello depositato. Registered design.

668/20+16 sospensione *suspension*





668/24 sospensione *suspension*















670/20 sospensione *suspension*





671/3S sospensione *suspension*





668/12PF plafoniera ceiling lamp



670/16PF plafoniera ceiling lamp

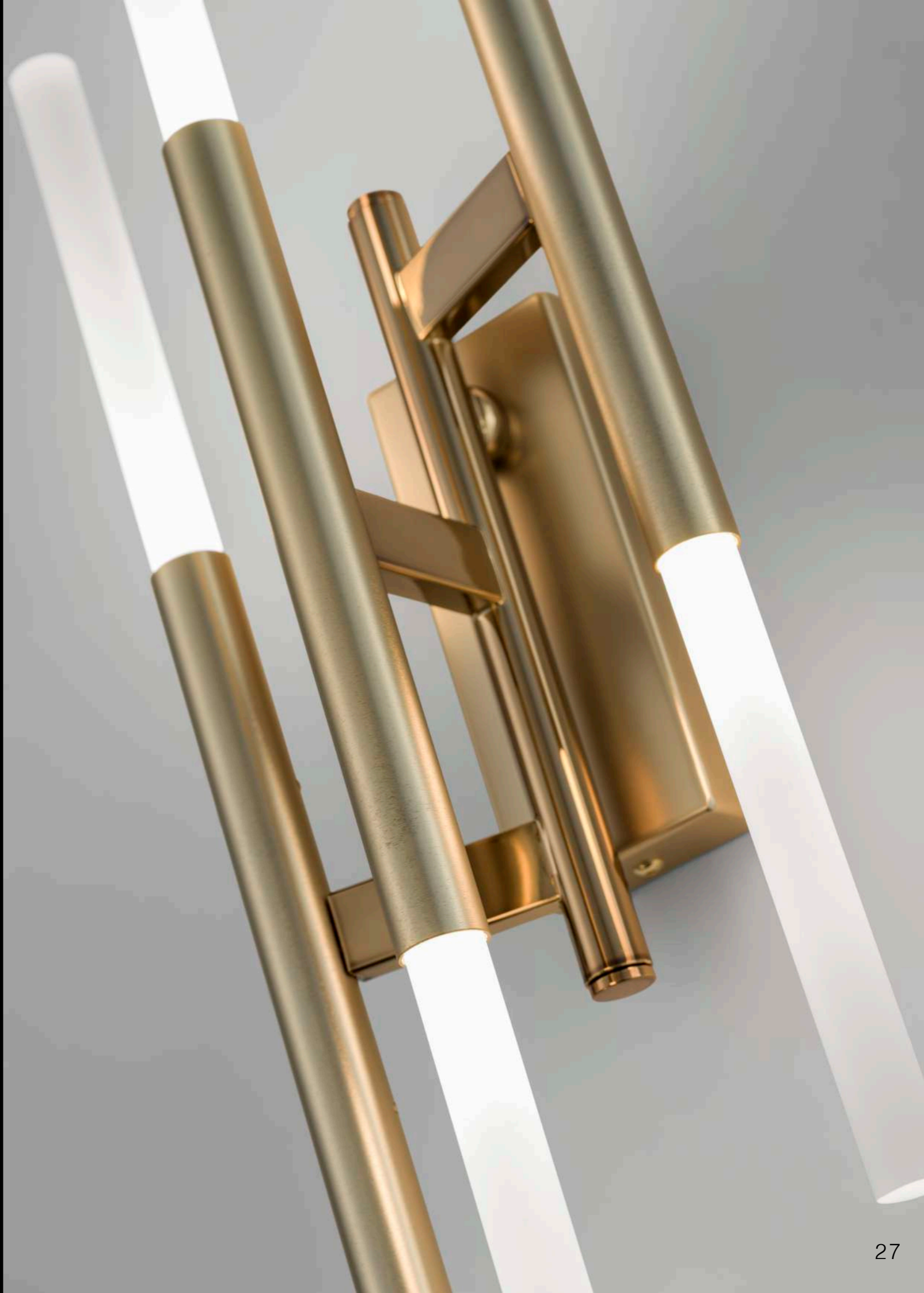

668/6A applique wall bracket



668/2A applique wall bracket



668/4A applique wall bracket

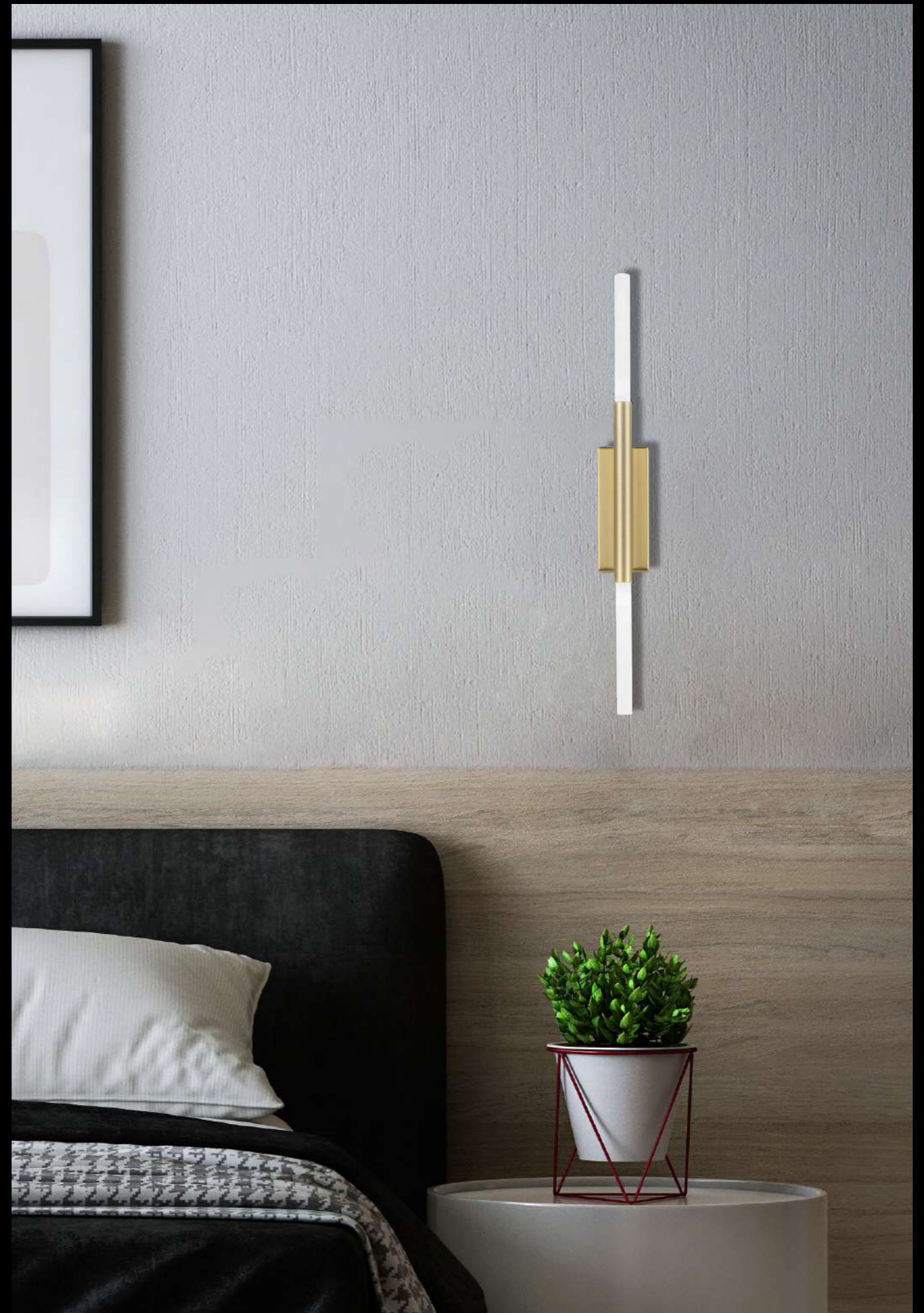



668/1LP lampada da tavolo *table lamp*



668/1LM lampada da tavolo *table lamp*

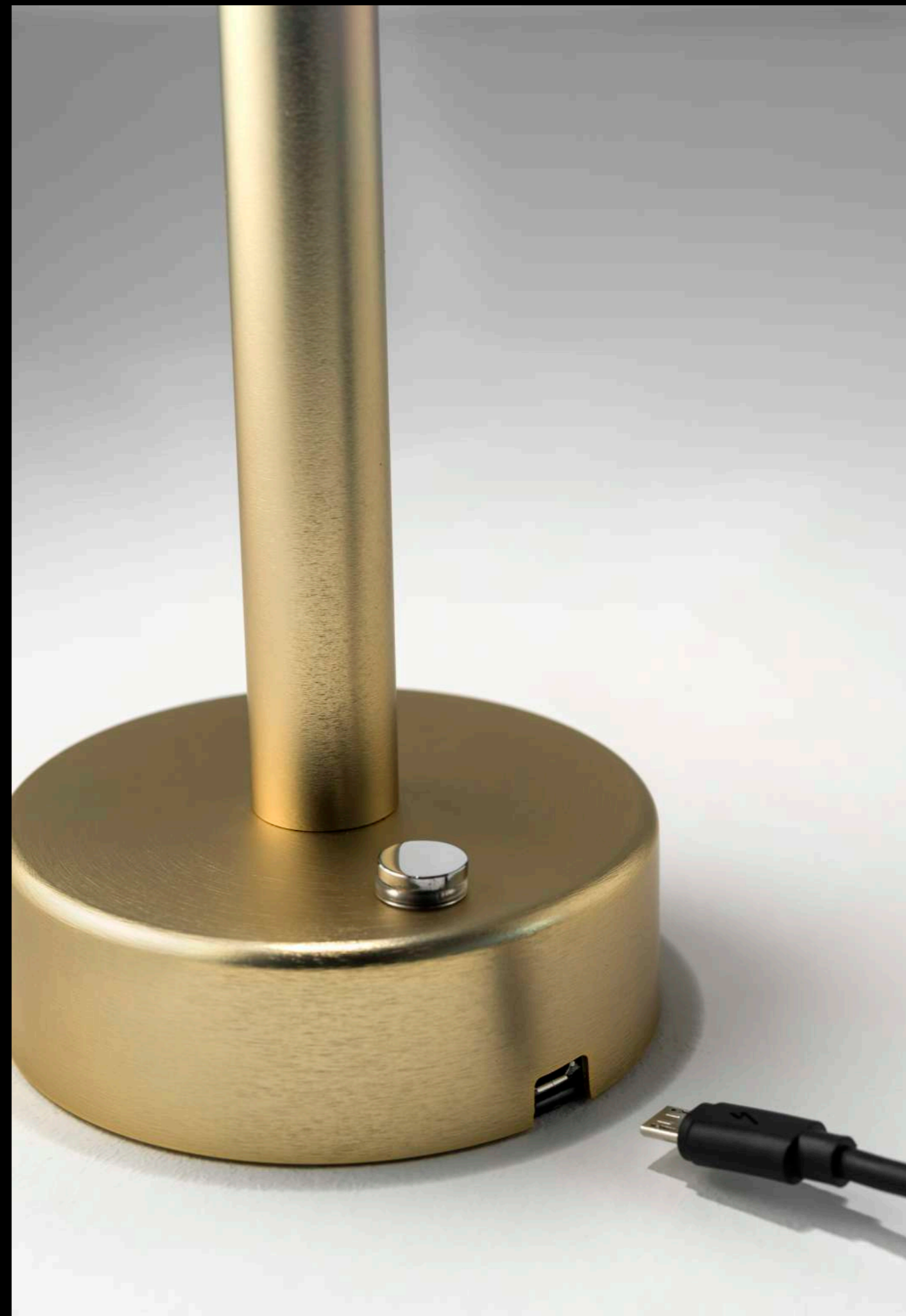





668/3L lampada da tavolo *table lamp*



668/1P lampada da terra *floor lamp*



668/6P lampada da terra floor lamp

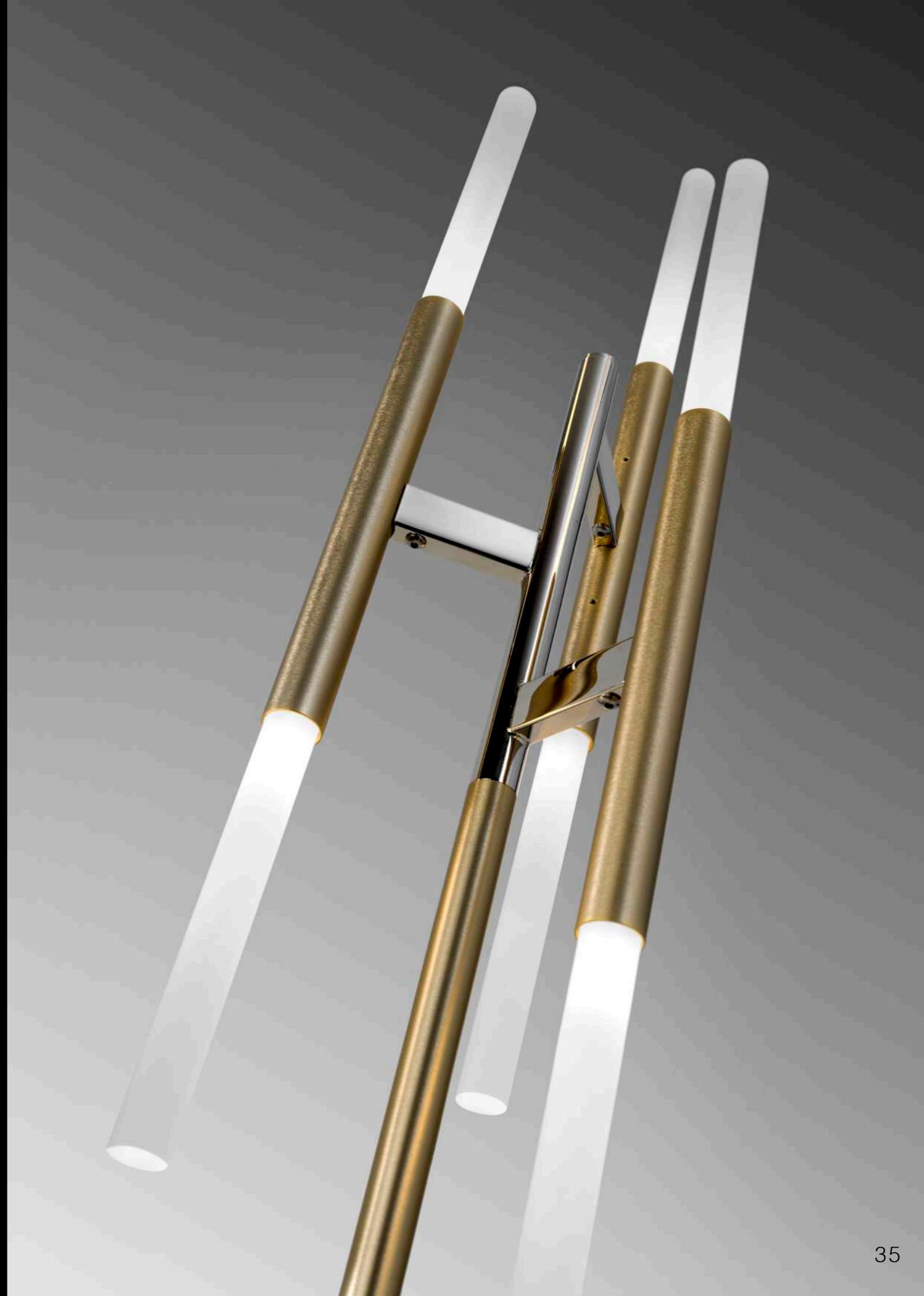



668/12P lampada da terra floor lamp



# EKLE'

DESIGN Cristian Feltrin



Oro spazzolato con pure steel  
brushed gold with pure steel

Oro spazzolato con bronzo  
brushed gold with bronze

Oro spazzolato con brunito corten  
brushed gold with burnished corten

Oro spazzolato  
brushed gold

Il telaio in metallo è disponibile nelle seguenti finiture:

- oro spazzolato con pure steel
- oro spazzolato con bronzo
- oro spazzolato con brunito corten
- oro spazzolato

Il diffusore è in plexiglass satinato.

Le lampade da tavolo, art. 668/1LP e art. 668/1LM sono ricaricabili tramite cavo USB incluso.

Le seguenti lampade sono dimmerabili: 668/20+16, 668/24, 668/20, 668/16, 668/12, 669/20,

The metal frame is available in the following finishes:

- brushed gold with pure steel
- brushed gold with bronze
- brushed gold with burnished corten
- brushed gold

The diffuser is in satin plexiglass.

The table lamps, art. 668 / 1LP and art. 668 / 1LM are rechargeable via the included USB cable.

The following lamps are dimmable: 668/20 + 16, 668/24, 668/20, 668/16, 668/12, 669/20, 670/20, 668 / 1LP, 668 / 1LM, 668 / 12P.

## PLAFONIERA CEILING LAMP

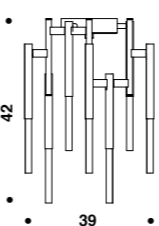
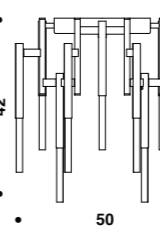
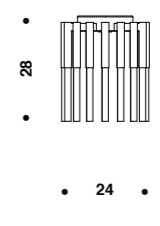
 <p><b>668/12PF</b> 12 x LED 1,42W 2400 lumen - 3000K CE ⊕ ▽</p> <p>42 39</p>	 <p><b>668/16PF</b> 16 x LED 1,42W 3200 lumen - 3000K CE ⊕ ▽</p> <p>42 50</p>	 <p><b>670/16PF</b> 16 x LED 1,42W 3200 lumen - 3000K CE ⊕ ▽</p> <p>28 24</p>
---	---	---

## APPLIQUE WALL BRACKET

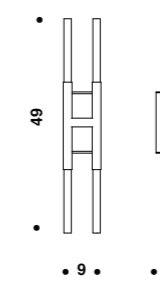
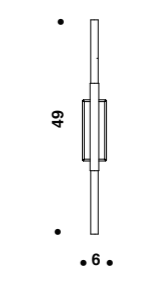
 <p><b>668/6A</b> 6 x LED 1,42W 1200 lumen - 3000K CE ⊕ ▽</p> <p>64 15 12</p>	 <p><b>668/4A</b> 4 x LED 1,42W 800 lumen - 3000K CE ⊕ ▽</p> <p>49 9 6</p>	 <p><b>668/2A</b> 2 x LED 1,42W 400 lumen - 3000K CE ⊕ ▽</p> <p>49 6 6</p>
--	---	---

## LAMPADA DA TAVOLO TABLE LAMP

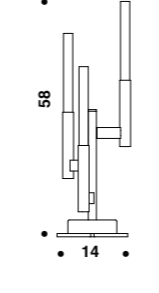
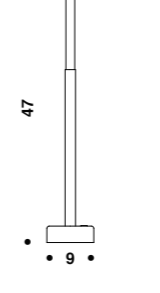
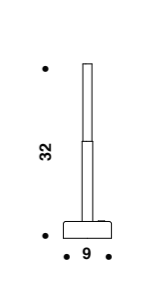
 <p><b>668/3L</b> 3 x LED 1,42W 600 lumen - 3000K CE ⊕ ▽</p> <p>68 14</p>	 <p><b>668/1LM</b> 1 x LED 1,42W 200 lumen - 3000K CE ⊕ ▽</p> <p>47 9</p>	 <p><b>668/1LP</b> 1 x LED 1,42W 200 lumen - 3000K CE ⊕ ▽</p> <p>32 9</p>
---	---	---

## LAMPADA DA TERRA FLOOR LAMP

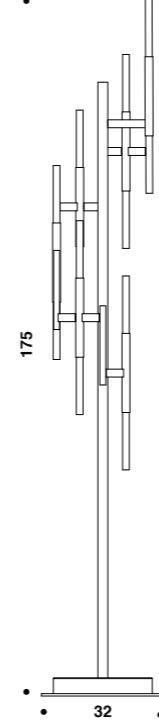
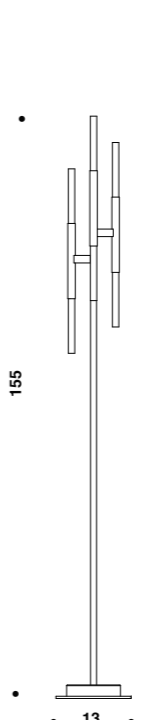
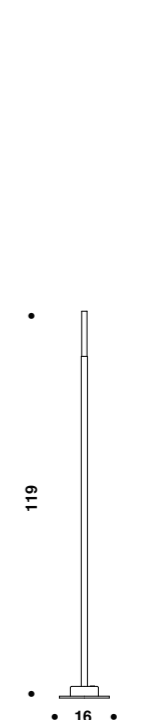
 <p><b>668/12P</b> 12 x LED 1,42W 2400 lumen - 3000K CE ⊕ ▽</p> <p>175 32</p>	 <p><b>668/6P</b> 6 x LED 1,42W 1200 lumen - 3000K CE ⊕ ▽</p> <p>155 13</p>	 <p><b>668/1P</b> 1 x LED 1,42W 200 lumen - 3000K CE ⊕ ▽</p> <p>119 16</p>
--	--	---

## SOSPENSIONE SUSPENSION

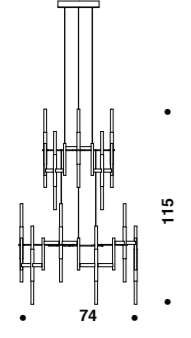
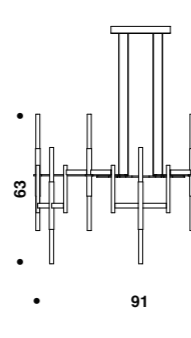
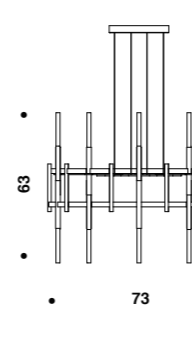
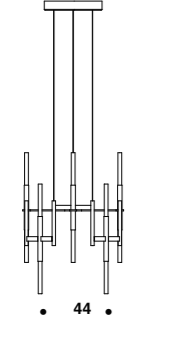
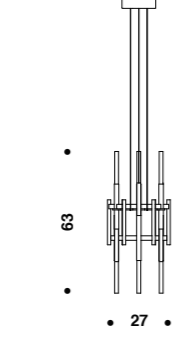
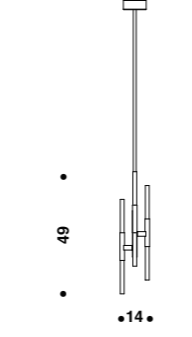
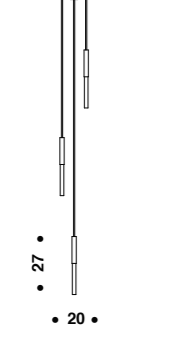
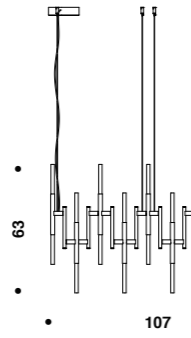
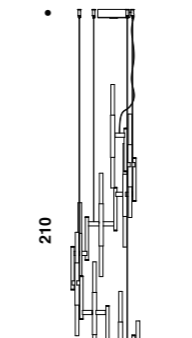
 <p><b>668/20+16</b> 36 x LED 1,42W 7200 lumen - 3000K CE ⊕ ▽</p> <p>147 115 74</p>	 <p><b>668/24</b> 24 x LED 1,42W 4800 lumen - 3000K CE ⊕ ▽</p> <p>63 91</p>	 <p><b>668/20</b> 20 x LED 1,42W 4000 lumen - 3000K CE ⊕ ▽</p> <p>63 73</p>
 <p><b>668/16</b> 16 x LED 1,42W 3200 lumen - 3000K CE ⊕ ▽</p> <p>63 44</p>	 <p><b>668/12</b> 12 x LED 1,42W 2400 lumen - 3000K CE ⊕ ▽</p> <p>63 27</p>	 <p><b>668/6</b> 6 x LED 1,42W 1200 lumen - 3000K CE ⊕ ▽</p> <p>49 14</p>
 <p><b>671/3S</b> 3 x LED 1,42W 600 lumen - 3000K CE ⊕ ▽</p> <p>111 27 20</p>	 <p><b>669/20</b> 20 x LED 1,42W 4000 lumen - 3000K CE ⊕ ▽</p> <p>63 107</p>	 <p><b>670/20</b> 20 x LED 1,42W 4000 lumen - 3000K CE ⊕ ▽</p> <p>210 40</p>

Le finiture CORTEN (brunito) e ORO ANTICO, è un procedimento di ossidazione naturale. La realizzazione di tale processo è influenzata dal livello di umidità, dalla temperatura esterna e da altre variabili ambientali. La mano dell'uomo e la specifica lavorazione sono il valore aggiunto che testimonia l'autentico 'Made in Italy'.

Come tutte le opere dove il procedimento non è meccanico ma artigianale le eventuali variazioni di colore non sono da considerarsi un difetto ma una testimonianza dell'unicità del prodotto. Le finiture Corten e Oro antico rendono quindi il prodotto unico e irripetibile. Le foto presenti nel nostro catalogo costituiscono solo un'identificazione del tipo di prodotto e non rappresentano un campione degli stessi.

The finishes CORTEN (burnished) and ANTIQUE GOLD are the result of a procedure of natural oxidation. The procedure is every time affected by the percentage of humidity in the air, by the external temperature and by other environmental variables. Hands of man and a special processing are a value added, which is evidence of the real 'Made in Italy'.

As in all works where the procedure is not mechanical but handcrafted, variations are possible, but they must not be considered as a defect, but rather as a proof of the uniqueness of the product. The Corten and Antique gold finishes makes the product as unique, since every results is not reproducible in identical way. The pictures of our catalogues are only an example of the kind of the product, but they cannot be considered strictly as samples of them, since the result can be different.



# Acropora

DESIGN *Cristian Feltrin*

Modello depositato. Registered design.



650/20 *sospensione suspension*

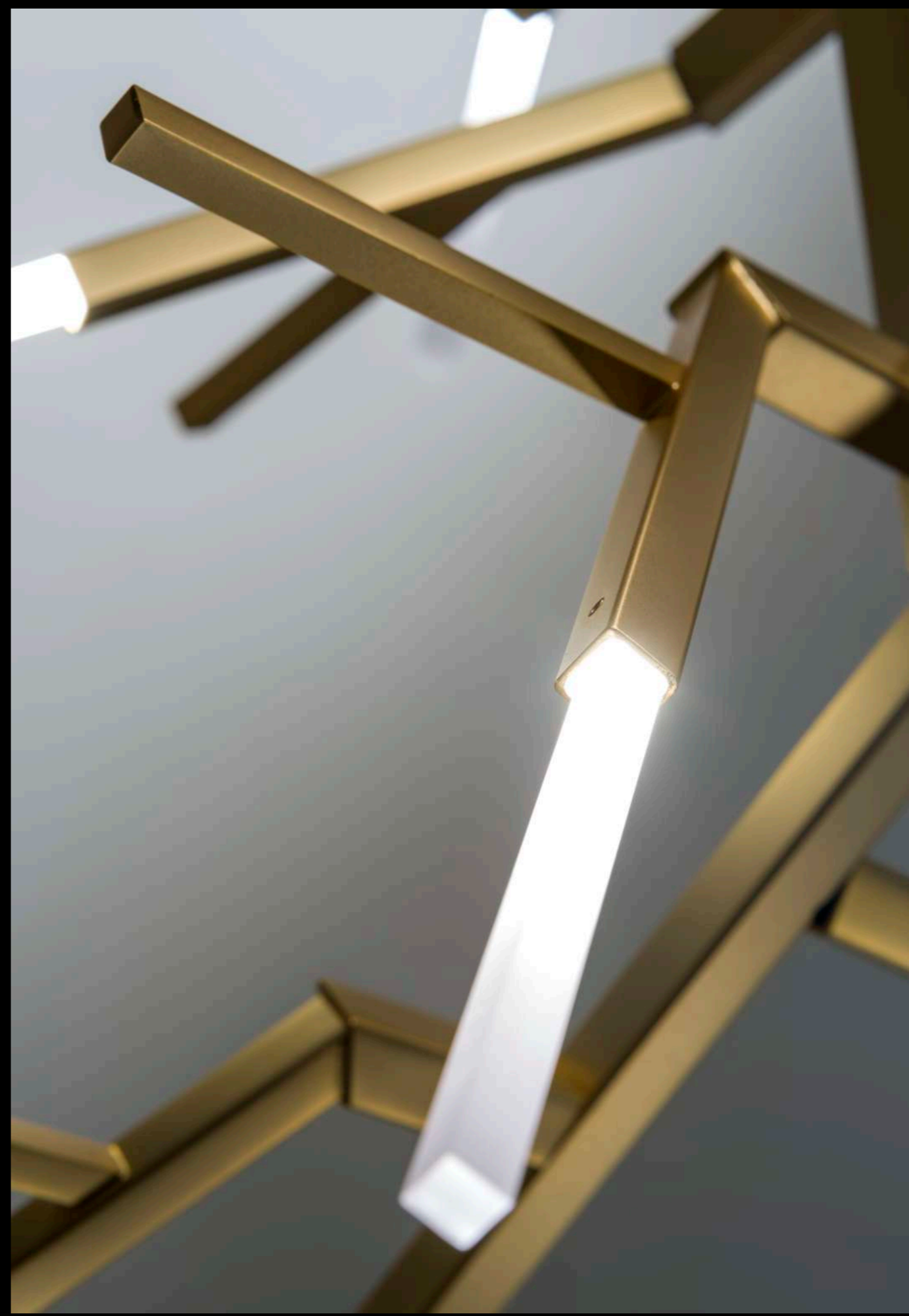



650/28 sospensione suspension



650/4A applique wall bracket



650/20 sospensione suspension





**651/15P** lampada da terra floor lamp



**650/5L** lampada da tavolo table lamp

# ACROPORA

DESIGN Cristian Feltrin



650/1L lampada da tavolo table lamp

Il telaio in metallo è disponibile nelle seguenti finiture:

- pure steel
- brunito corten
- oro chiaro
- nichel nero
- oro antico lucido
- oro antico opaco
- oro opaco

Il diffusore è in plexiglass satinato.

Nota: art. 650/5L e art. 651/15P con il push button per dimmerare incluso.

Metal frame is available in the following finishes:

- pure steel
- burnished corten
- light gold
- black nickel
- glossy antique gold
- matt antique gold
- matt gold

Diffuser in satin plexiglas.

Note: art. 650/5L e art. 651/15P are supplied with push button dimmer switch included



brunito corten  
burnished corten

pure steel  
pure steel

oro chiaro  
light gold

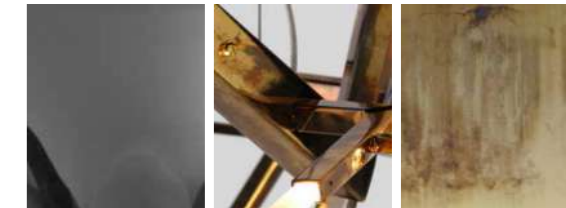

nichel nero  
black nickel



oro antico lucido  
glossy antique gold

oro antico opaco  
matt antique gold



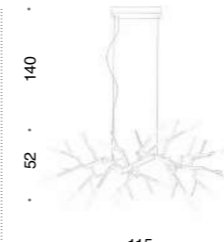
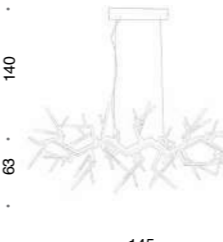
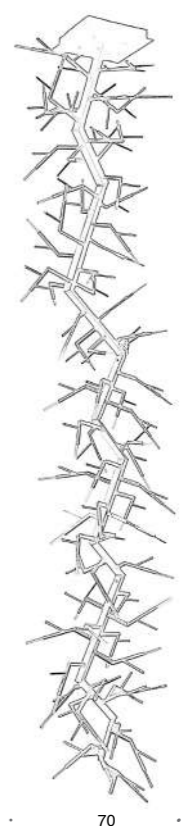

oro opaco  
matt gold

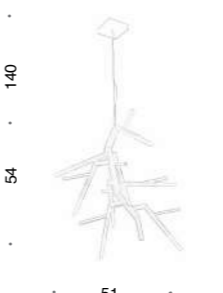
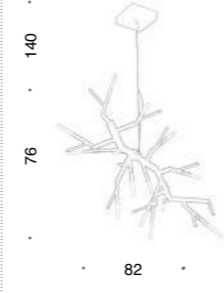
## SOSPENSIONE SUSPENSION

 <p><b>650/20</b> 20 x LED 1W 2500 lumen - 3000 K CE ⊕ ▽</p> <p>140 52 115</p>	 <p><b>650/28</b> 28 x LED 1W 3500 lumen - 3000 K CE ⊕ ▽</p> <p>140 68 145</p>	 <p><b>651/60</b> 60 x LED 1W 8000 lumen - 3000 K CE ⊕ ▽</p> <p>324 70</p>
 <p><b>650/3</b> 3 x LED 1W 450 lumen - 3000 K CE ⊕ ▽</p> <p>200 42</p>	 <p><b>651/9</b> 9 x LED 1W 1200 lumen - 3000 K CE ⊕ ▽</p> <p>140 54 51</p>	
 <p><b>651/14</b> 14 x LED 1W 1750 lumen - 3000 K CE ⊕ ▽</p> <p>140 76 82</p>		

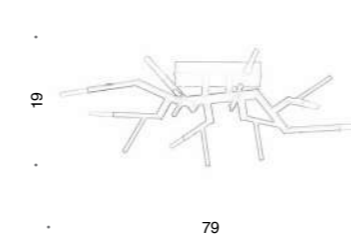
## PLAFONIERA CEILING LAMP

 <p><b>650/8PF</b> 8 x LED 1W 1000 lumen - 3000 K CE ⊕ ▽</p> <p>19 79</p>	 <p><b>651/9PF</b> 9 x LED 1W 1200 lumen - 3000 K CE ⊕ ▽</p> <p>51</p>
--	---

## APPLIQUE WALL BRACKET

## LAMPADA DA TAVOLO TABLE LAMP

## LAMPADA DA TERRA FLOOR LAMP

 <p><b>650/4A</b> 4 x LED 1W 500 lumen - 3000 K CE ⊕ ▽</p> <p>46 42</p>	 <p><b>650/1L</b> 1 x LED 1W 150 lumen - 3000 K CE ⊕ ▽</p> <p>16 30</p>	 <p><b>650/5L</b> 5 x LED 1W 650 lumen - 3000 K CE ⊕ ▽</p> <p>60 42</p>	 <p><b>651/15P</b> 15 x LED 1W 1900 lumen - 3000 K CE ⊕ ▽</p> <p>188 57</p>
---	--	--	--

Le finiture CORTEN (brunito) e ORO ANTICO, è un procedimento di ossidazione naturale. La realizzazione di tale processo è influenzata dal livello di umidità, dalla temperatura esterna e da altre variabili ambientali. La mano dell'uomo e la specifica lavorazione sono il valore aggiunto che testimonia l'autentico 'Made in Italy'.

Come tutte le opere dove il procedimento non è meccanico ma artigianale le eventuali variazioni di colore non sono da considerarsi un difetto ma una testimonianza dell'unicità del prodotto. Le finiture Corten e Oro antico rendono quindi il prodotto unico e irripetibile. Le foto presenti nel nostro catalogo costituiscono solo un'identificazione del tipo di prodotto e non rappresentano un campione degli stessi.

The finishes CORTEN (burnished) and ANTIQUE GOLD are the result of a procedure of natural oxidation. The procedure is every time affected by the percentage of humidity in the air, by the external temperature and by other environmental variables. Hands of man and a special processing are a value added, which is evidence of the real 'Made in Italy'.

As in all works where the procedure is not mechanical but handcrafted, variations are possible, but they must not be considered as a defect, but rather as a proof of the uniqueness of the product. The Corten and Antique gold finishes makes the product as unique, since every results is not reproducible in identical way. The pictures of our catalogues are only an example of the kind of the product, but they cannot be considered strictly as samples of them, since the result can be different.



Miu

DESIGN *Cristian Feltrin*

656/7SL *sospensione suspension*

Modello depositato. Registered design.

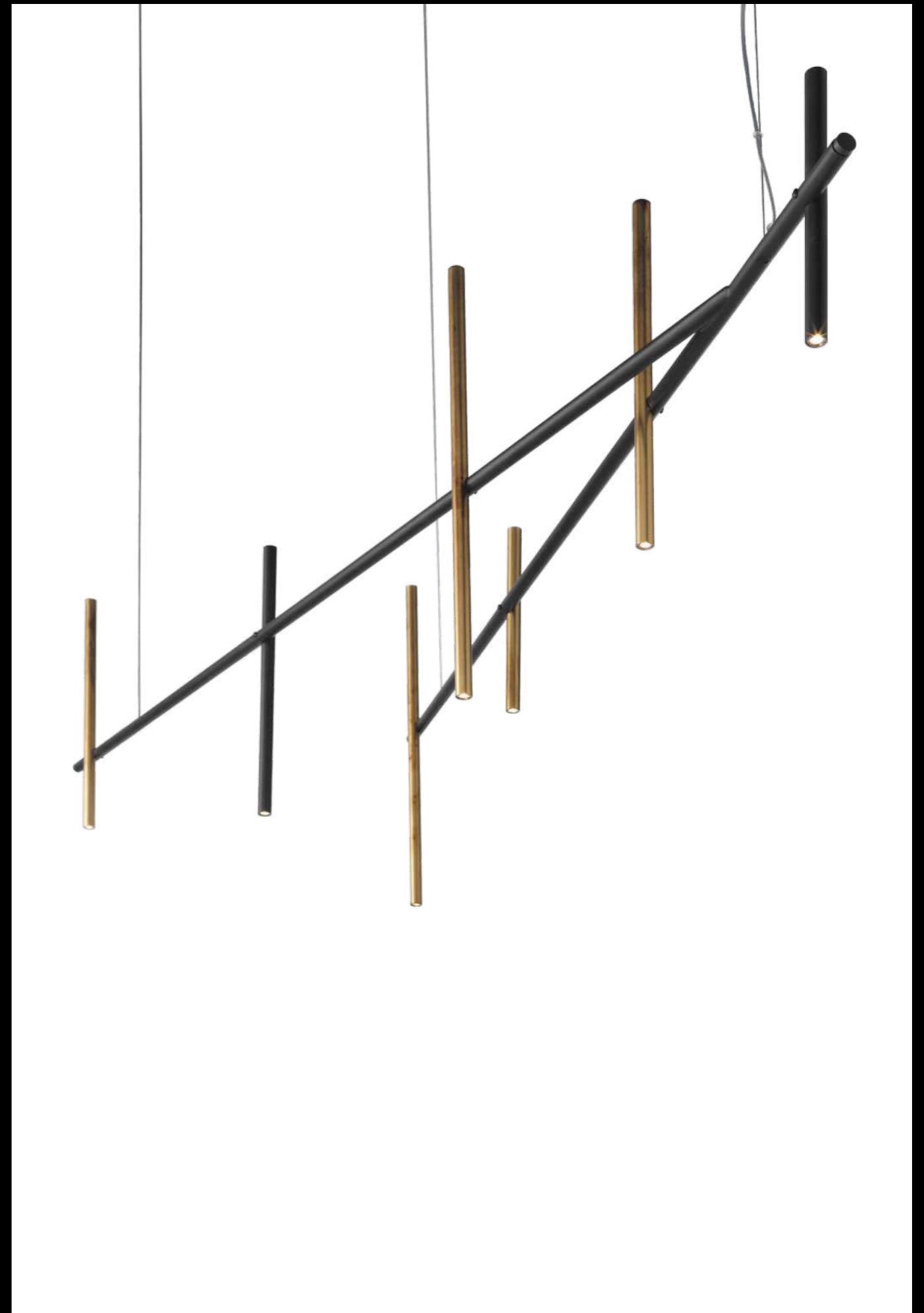



656/9 *sospensione suspension*



656/1SP *sospensione suspension*

656/1SG *sospensione suspension*



656/2A applique wall lamp

# MIU

DESIGN Cristian Feltrin



brunito corten  
burnished corten  
oro antico opaco  
matt antique gold  
pure steel  
pure steel  
oro chiaro  
light gold

Il telaio in metallo è disponibile nelle seguenti finiture:

- brunito corten
- oro antico opaco
- pure steel
- oro chiaro

Metal frame is available in the following finishes:

- burnished corten
- matt antique gold
- pure steel
- light gold

Sospensioni singole con attacco per soffitto in cartongesso - cod. 657

Singular suspensions with support for drywall ceiling - art. 657

## SOSPENSIONE SUSPENSION

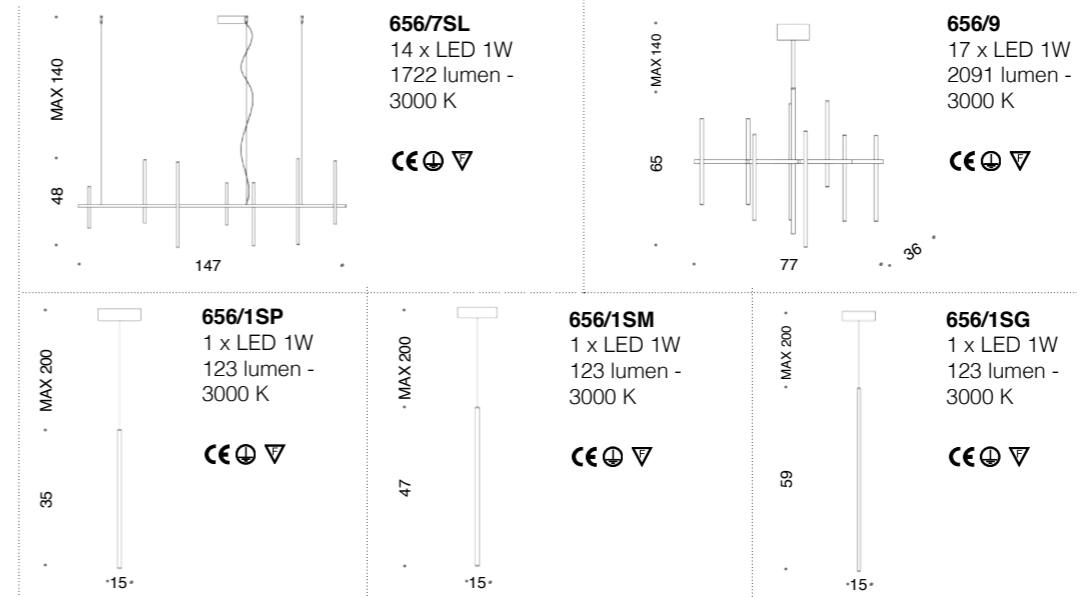

## SOSPENSIONE ( PER CARTONGESSO ) SUSPENSION ( FOR DRYWALL )

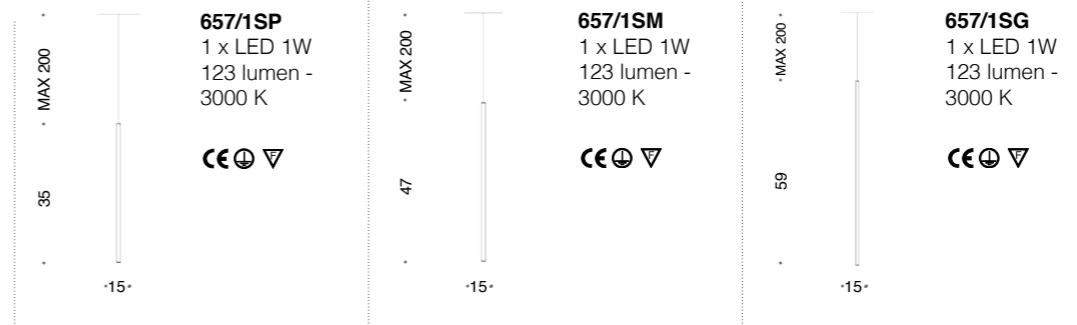

## APPLIQUE WALL BRACKET

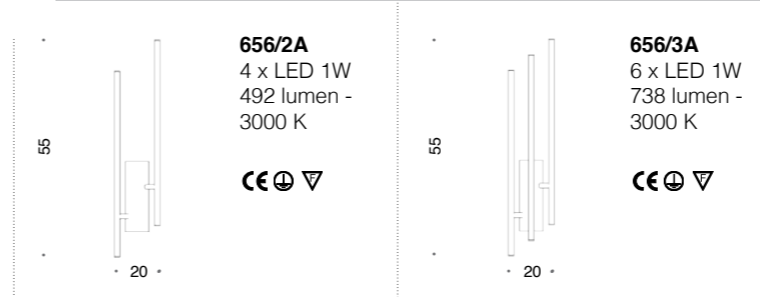

Le finiture CORTEN (brunito) e ORO ANTICO, è un procedimento di ossidazione naturale. La realizzazione di tale processo è influenzata dal livello di umidità, dalla temperatura esterna e da altre variabili ambientali. La mano dell'uomo e la specifica lavorazione sono il valore aggiunto che testimonia l'autentico 'Made in Italy'.

Come tutte le opere dove il procedimento non è meccanico ma artigianale le eventuali variazioni di colore non sono da considerarsi un difetto ma una testimonianza dell'unicità del prodotto. Le finiture Corten e Oro antico rendono quindi il prodotto unico e irripetibile. Le foto presenti nel nostro catalogo costituiscono solo un'identificazione del tipo di prodotto e non rappresentano un campione degli stessi.

The finishes CORTEN (burnished) and ANTIQUE GOLD are the result of a procedure of natural oxidation. The procedure is every time affected by the percentage of humidity in the air, by the external temperature and by other environmental variables. Hands of man and a special processing are a value added, which is evidence of the real 'Made in Italy'.

As in all works where the procedure is not mechanical but handcrafted, variations are possible, but they must not be considered as a defect, but rather as a proof of the uniqueness of the product. The Corten and Antique gold finishes makes the product as unique, since every results is not reproducible in identical way. The pictures of our catalogues are only an example of the kind of the product, but they cannot be considered strictly as samples of them, since the result can be different.

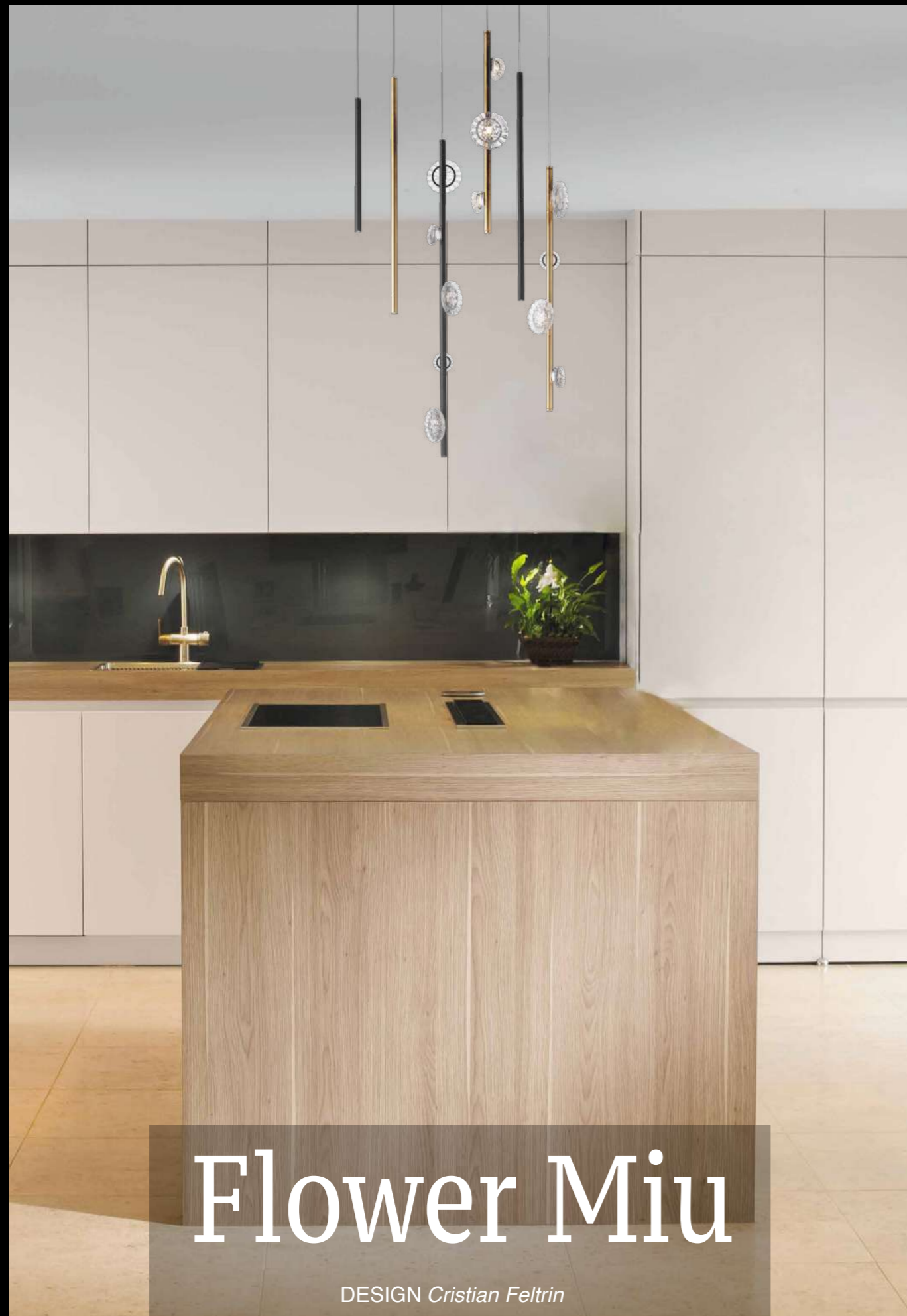

# Flower Miu

DESIGN *Cristian Feltrin*

655/3+3 *sospensione suspension*

Modello depositato. Registered design.



658/1SP *sospensione suspension*

658/1SG *sospensione suspension*

658/1SM *sospensione suspension*



655/9SL *sospensione suspension*





655/7 *sospensione suspension*



655/4 *sospensione suspension*





64 **655/LP** lampada da tavolo table lamp

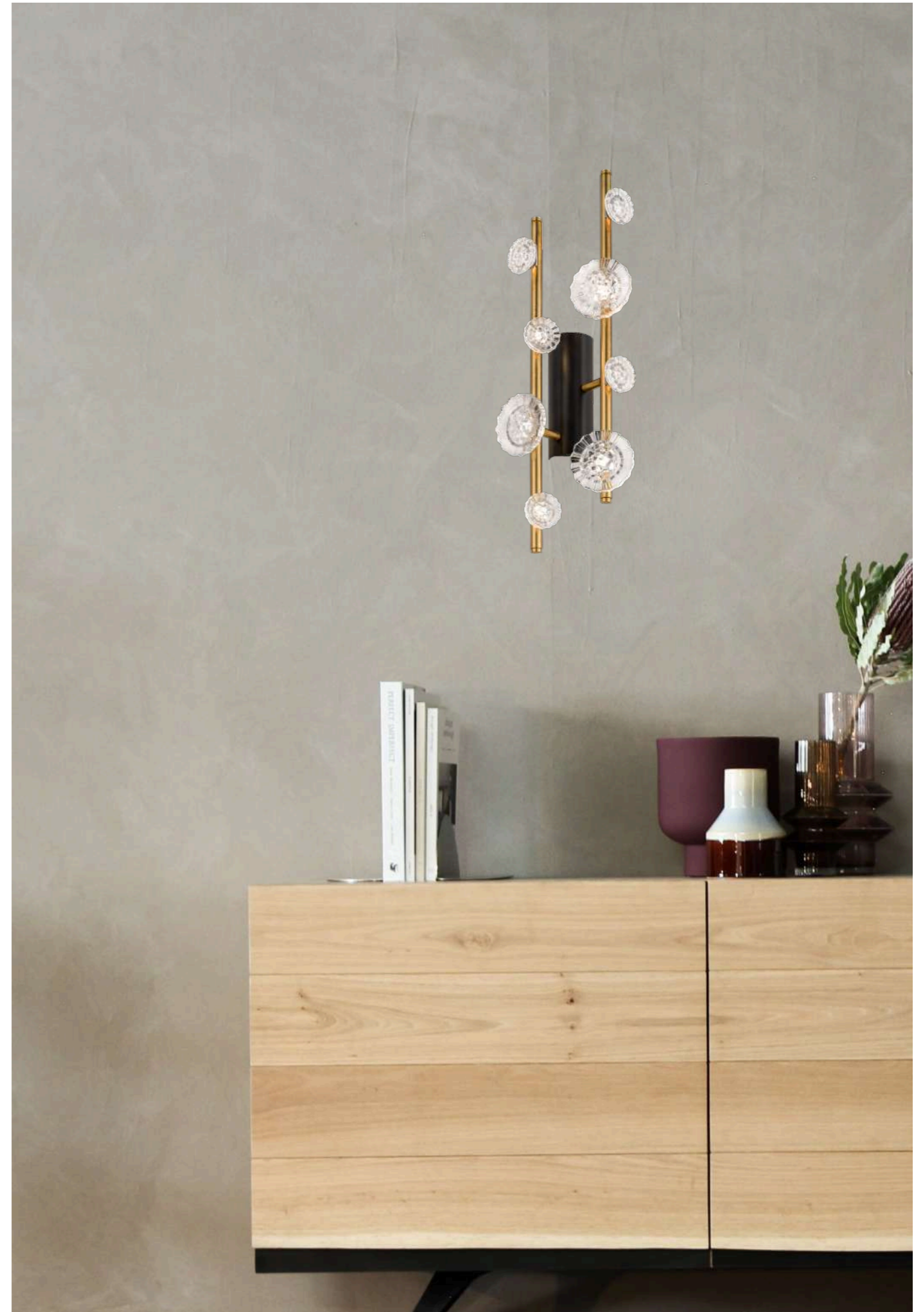

**655/2A** applique wall bracket

# FLOWER MIU

DESIGN Cristian Feltrin



*brunito corten*  
burnished corten  
*oro antico opaco*  
matt antique gold  
*pure steel*  
pure steel  
*oro chiaro*  
light gold

Il telaio in metallo è disponibile nelle seguenti finiture:

- brunito corten
- oro antico opaco
- pure steel
- oro chiaro

Metal frame is available in the following finishes:

- burnished corten
- matt antique gold
- pure steel
- light gold

Diffusore in vetro di Murano trasparente.

Transparent Murano glass diffuser.

Sospensioni singole con attacco per soffitto in cartongesso - cod. 658

Singular suspensions with support for drywall ceiling - art. 658

## SOSPENSIONE SUSPENSION

 59 MAX 140 240	<b>655/9SL</b> 27 x LED 1W 3321 lumen - 3000 K CE ⊕ ▽	 60 MAX 140 52 15	<b>655/7</b> 17 x LED 1W 2091 lumen - 3000 K CE ⊕ ▽	 MAX 200 52	<b>655/3+3</b> 15 x LED 1W 1845 lumen - 3000 K CE ⊕ ▽
 59 MAX 140 36	<b>655/4</b> 11 x LED 1W 1353 lumen - 3000 K CE ⊕ ▽	 47 MAX 200 15	<b>655/1SP</b> 3 x LED 1W 369 lumen - 3000 K CE ⊕ ▽	 59 MAX 200 15	<b>655/1SM</b> 4 x LED 1W 492 lumen - 3000 K CE ⊕ ▽
		 80 MAX 200 15	<b>655/1SG</b> 5 x LED 1W 615 lumen - 3000 K CE ⊕ ▽		

## SOSPENSIONE ( PER CARTONGESSO ) SUSPENSION ( FOR DRYWALL )

 47 MAX 200 15	<b>658/1SP</b> 3 x LED 1W 369 lumen - 3000 K CE ⊕ ▽	 59 MAX 200 15	<b>658/1SM</b> 4 x LED 1W 492 lumen - 3000 K CE ⊕ ▽	 80 MAX 200 15	<b>658/1SG</b> 5 x LED 1W 615 lumen - 3000 K CE ⊕ ▽
-------------------------	---	-------------------------	---	-------------------------	---

## LAMPADA DA TERRA FLOOR LAMP

 180 31	<b>655/3P</b> 15 x LED 1W 1845 lumen - 3000 K CE ⊕ ▽
---------------	--

## APPLIQUE WALL BRACKET

 47 9	<b>655/1A</b> 4 x LED 1W 492 lumen - 3000 K CE ⊕ ▽	 55 20	<b>655/2A</b> 8 x LED 1W 984 lumen - 3000 K CE ⊕ ▽
-------------	--	--------------	--

## LAMPADA DA TAVOLO TABLE LAMP

 88 13	<b>655/LP</b> 3 x LED 1W 369 lumen - 3000 K CE ⊕ ▽	 50 13	<b>655/LG</b> 4 x LED 1W 492 lumen - 3000 K CE ⊕ ▽
--------------	--	--------------	--

Le finiture CORTEN (brunito) e ORO ANTICO, è un procedimento di ossidazione naturale. La realizzazione di tale processo è influenzata dal livello di umidità, dalla temperatura esterna e da altre variabili ambientali. La mano dell'uomo e la specifica lavorazione sono il valore aggiunto che testimonia l'autentico 'Made in Italy'.

Come tutte le opere dove il procedimento non è meccanico ma artigianale le eventuali variazioni di colore non sono da considerarsi un difetto ma una testimonianza dell'unicità del prodotto. Le finiture Corten e Oro antico rendono quindi il prodotto unico e irripetibile. Le foto presenti nel nostro catalogo costituiscono solo un'identificazione del tipo di prodotto e non rappresentano un campione degli stessi.

The finishes CORTEN (burnished) and ANTIQUE GOLD are the result of a procedure of natural oxidation. The procedure is every time affected by the percentage of humidity in the air, by the external temperature and by other environmental variables. Hands of man and a special processing are a value added, which is evidence of the real 'Made in Italy'.

As in all works where the procedure is not mechanical but handcrafted, variations are possible, but they must not be considered as a defect, but rather as a proof of the uniqueness of the product. The Corten and Antique gold finishes makes the product as unique, since every results is not reproducible in identical way. The pictures of our catalogues are only an example of the kind of the product, but they cannot be considered strictly as samples of them, since the result can be different.



655/3P lampada da terra floor lamp



# Artic

DESIGN *Cristian Feltrin*





642/70 *sospensione suspension*



641/90 *sospensione suspension*

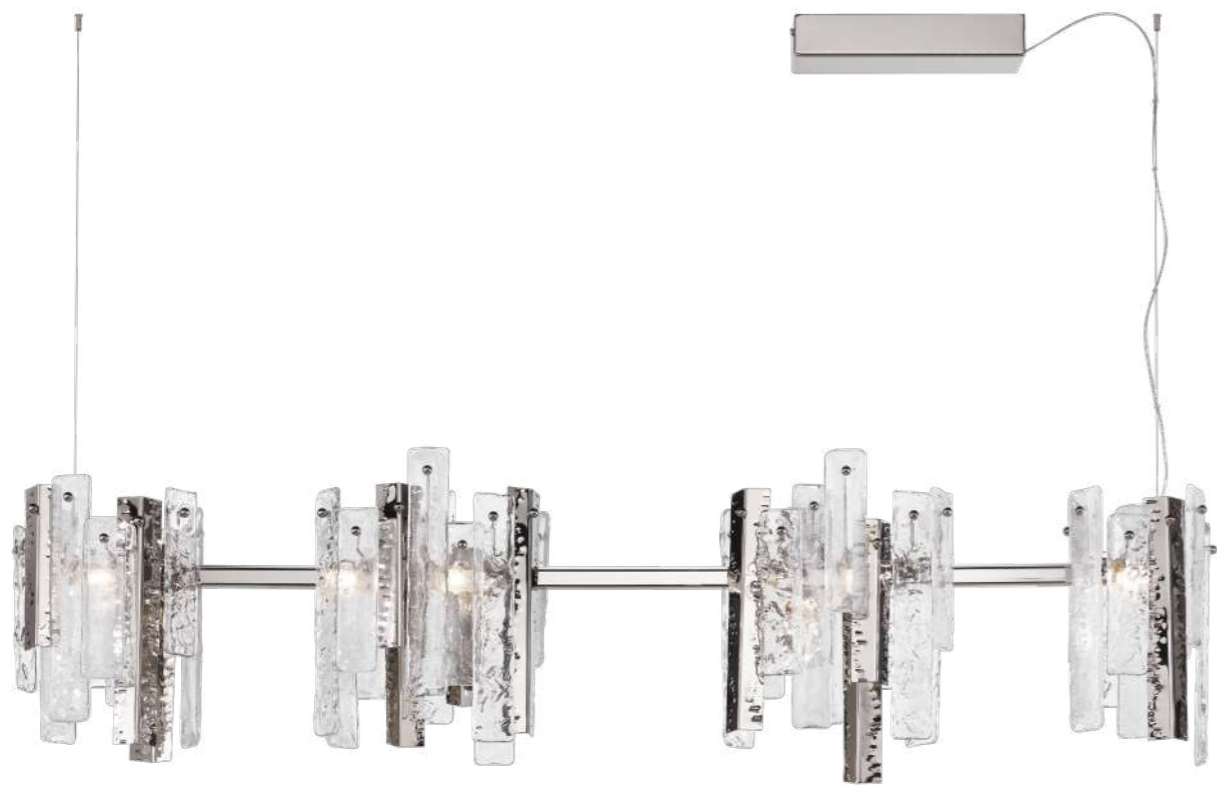

643/12 *sospensione suspension*



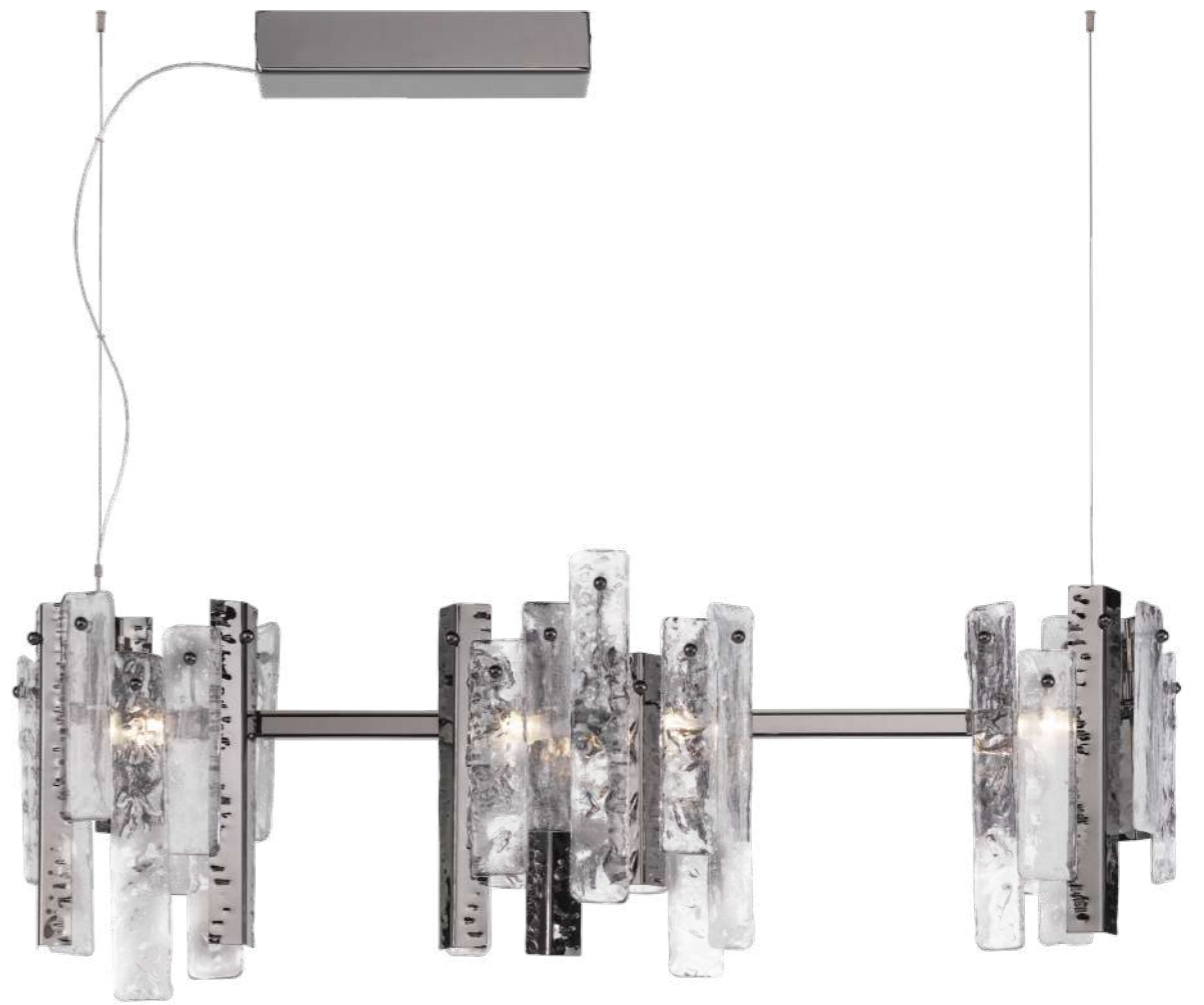

643/10 *sospensione suspension*



642/150 *sospensione suspension*



643/4 *sospensione suspension*



642/60PF plafoniera ceiling lamp





642/L lampada da tavolo table lamp

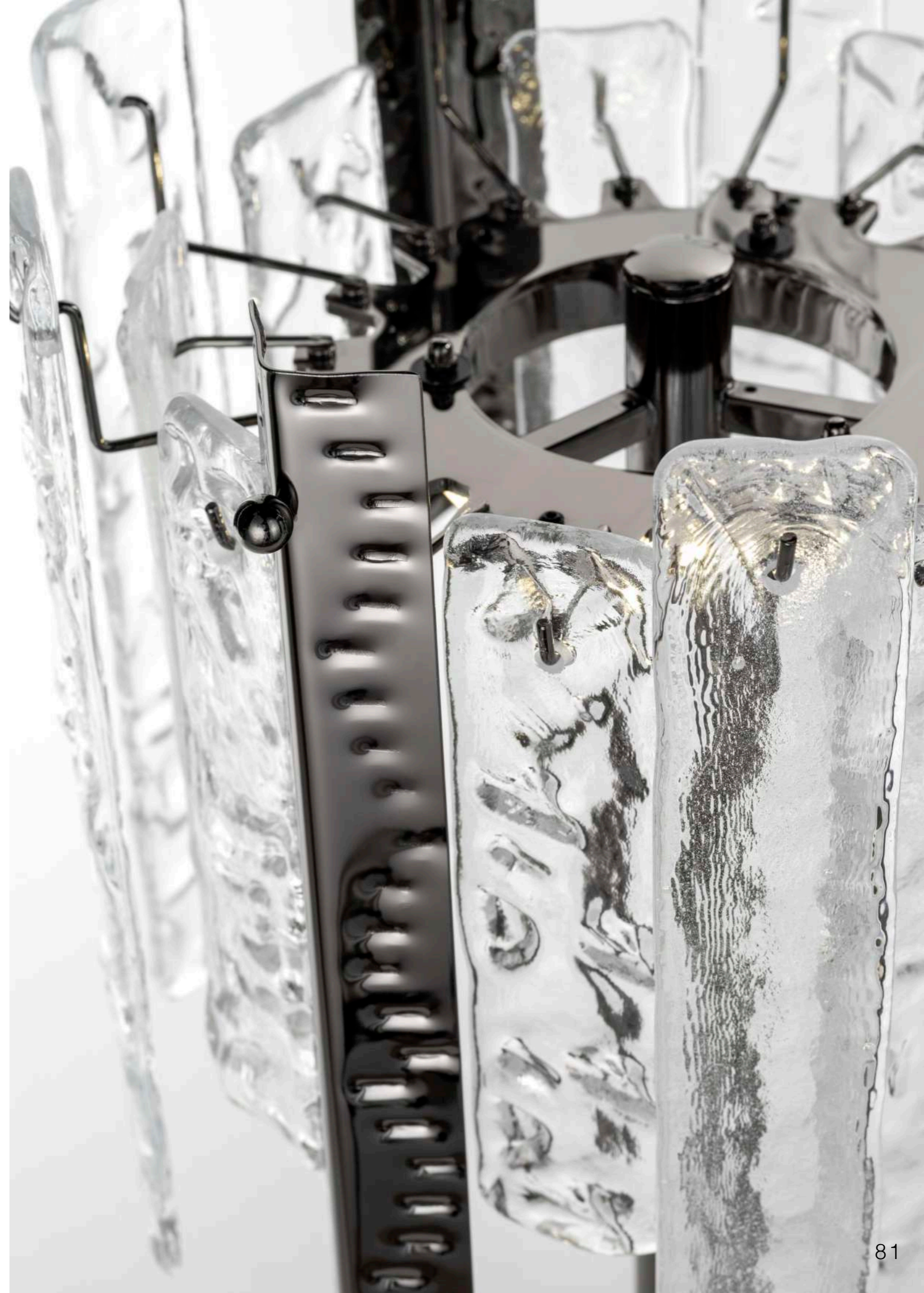

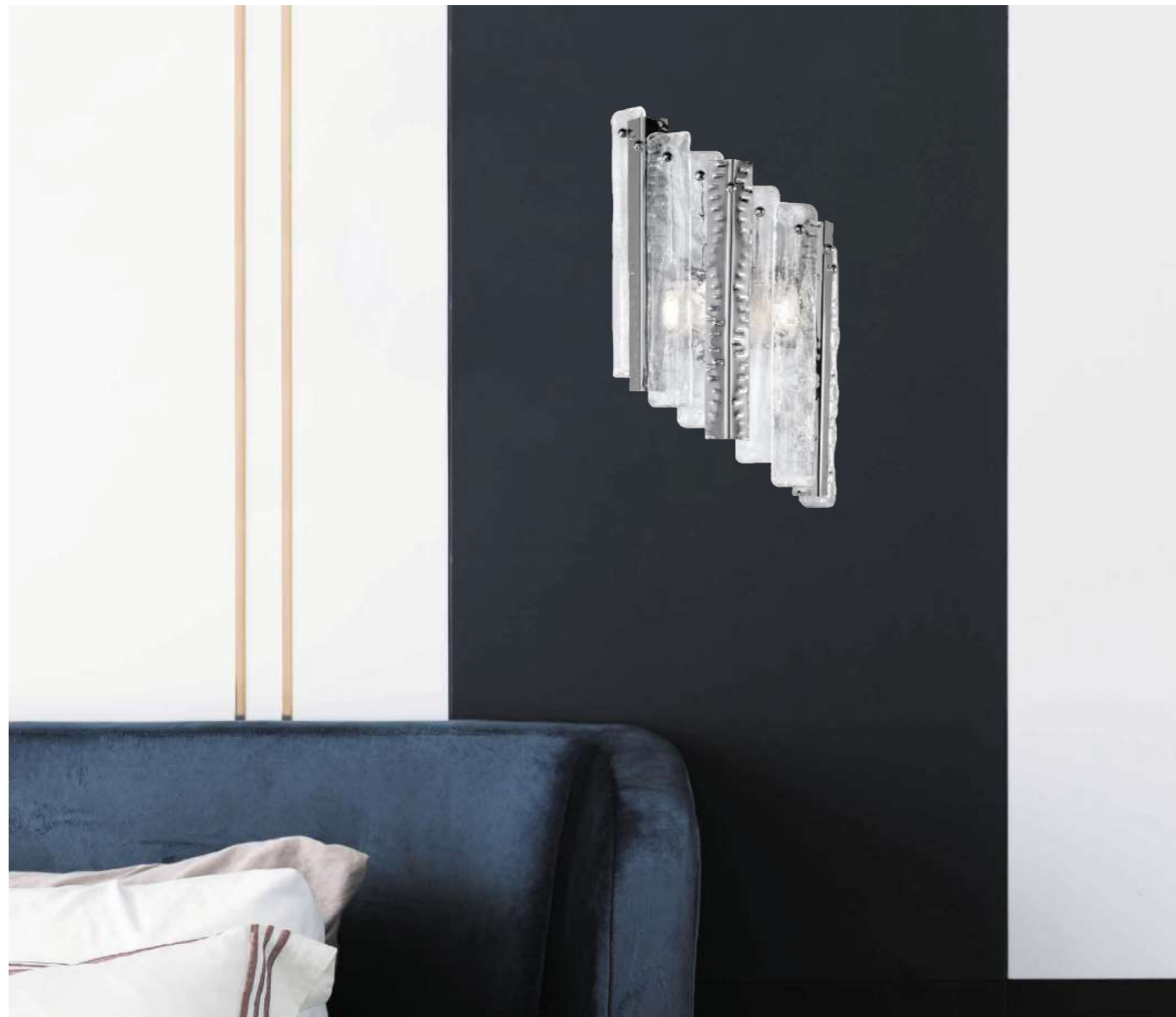

642/3ADX applique wall bracket

# ARTIC

DESIGN Cristian Feltrin

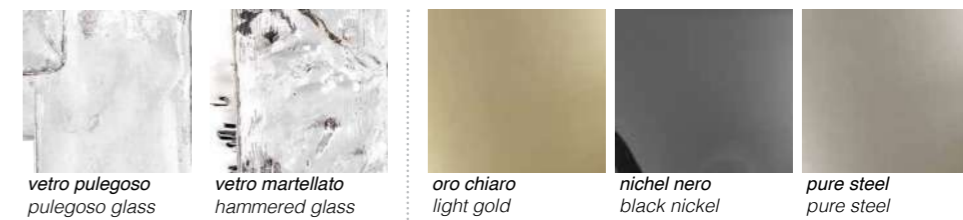

vetro pulegoso  
pulegoso glass

vetro martellato  
hammered glass

oro chiaro  
light gold

nicel nero  
black nickel

pure steel  
pure steel

Il telaio in metallo è disponibile nelle seguenti finiture:

- oro chiaro
- nicel nero
- pure steel

Metal frame is available in the following finishes:

- light gold
- black nickel
- pure steel

Vetro di Murano trasparente pulegoso e martellato abbinato con lame in metallo oro chiaro, nicel nero o pure steel.

Pulegoso or hammered transparent Murano glass with light gold, black nickel or pure steel metal blades.

## SOSPENSIONE SUSPENSION

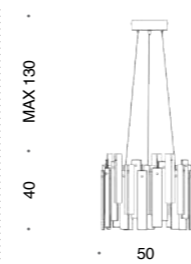

**642/50**  
1 STRIP LED  
MAX 15W  
1152 lumen - 3000 K  
CE ⊕ ▽

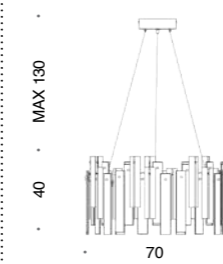

**642/70**  
1 x STRIP LED  
MAX 25W  
1960 lumen - 3000 K  
CE ⊕ ▽

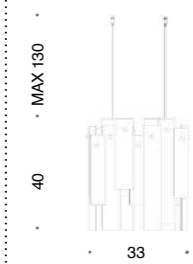

**643/4**  
4 x LED 3,6W  
1540 lumen - 3000 K  
CE ⊕ ▽

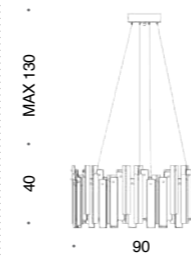

**642/90**  
1 STRIP LED  
MAX 35W  
2650 lumen - 3000 K  
CE ⊕ ▽

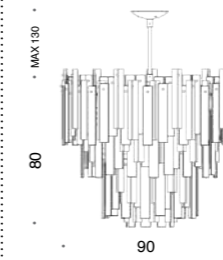

**641/90**  
4 STRIP LED  
MAX 78W  
6221 lumen - 3000 K  
CE ⊕ ▽

## PLAFONIERA CEILING LAMP

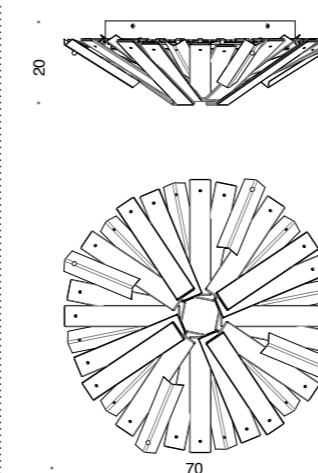

**642/60PF**  
2 STRIP LED  
MAX 37W  
2973 lumen - 3000 K  
CE ⊕ ▽

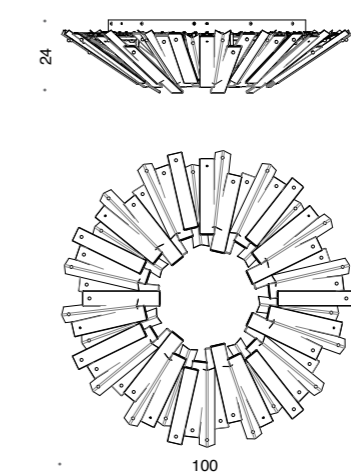

**642/90PF**  
2 STRIP LED  
MAX 55W  
4378 lumen - 3000 K  
CE ⊕ ▽

## SOSPENSIONE SUSPENSION

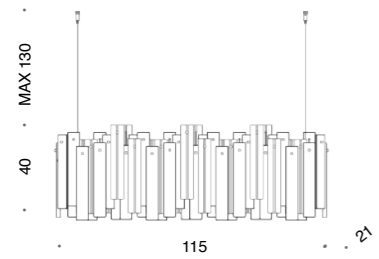

**642/115**  
10 x LED 3,6W  
3850 lumen - 3000 K  
CE ⊕ ▽

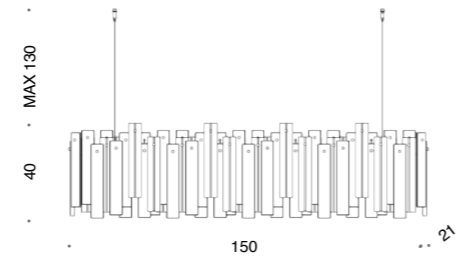

**642/150**  
14 x LED 3,6W  
5390 lumen - 3000 K  
CE ⊕ ▽

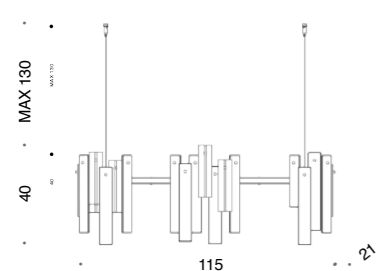

**643/10**  
8 x LED 3,6W  
3080 lumen - 3000 K  
CE ⊕ ▽

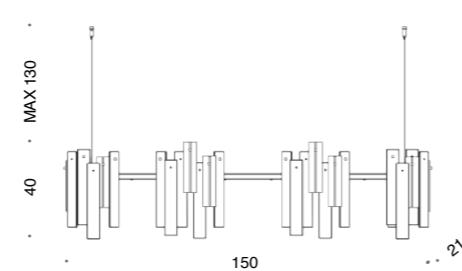

**643/12**  
12 x LED 3,6W  
4620 lumen - 3000 K  
CE ⊕ ▽

## APPLIQUE WALL BRACKET

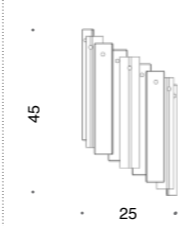

**642/3ADX**  
3 x LED 3,6W  
1155 lumen - 3000 K  
CE ⊕ ▽

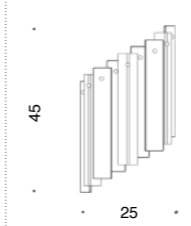

**642/3ASX**  
3 x LED 3,6W  
1155 lumen - 3000 K  
CE ⊕ ▽

## LAMPADA DA TAVOLO TABLE LAMP

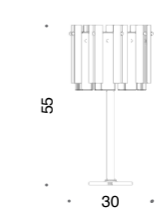

**642/L**  
1 STRIP LED  
MAX 9,2W  
660 lumen - 3000 K  
CE ⊕ ▽



# Ice Rain

DESIGN *Cristian Feltrin*

507/12 *sospensione suspension*

507/18 *sospensione suspension*

Modello depositato. Registered design.





508/12 sospensione suspension



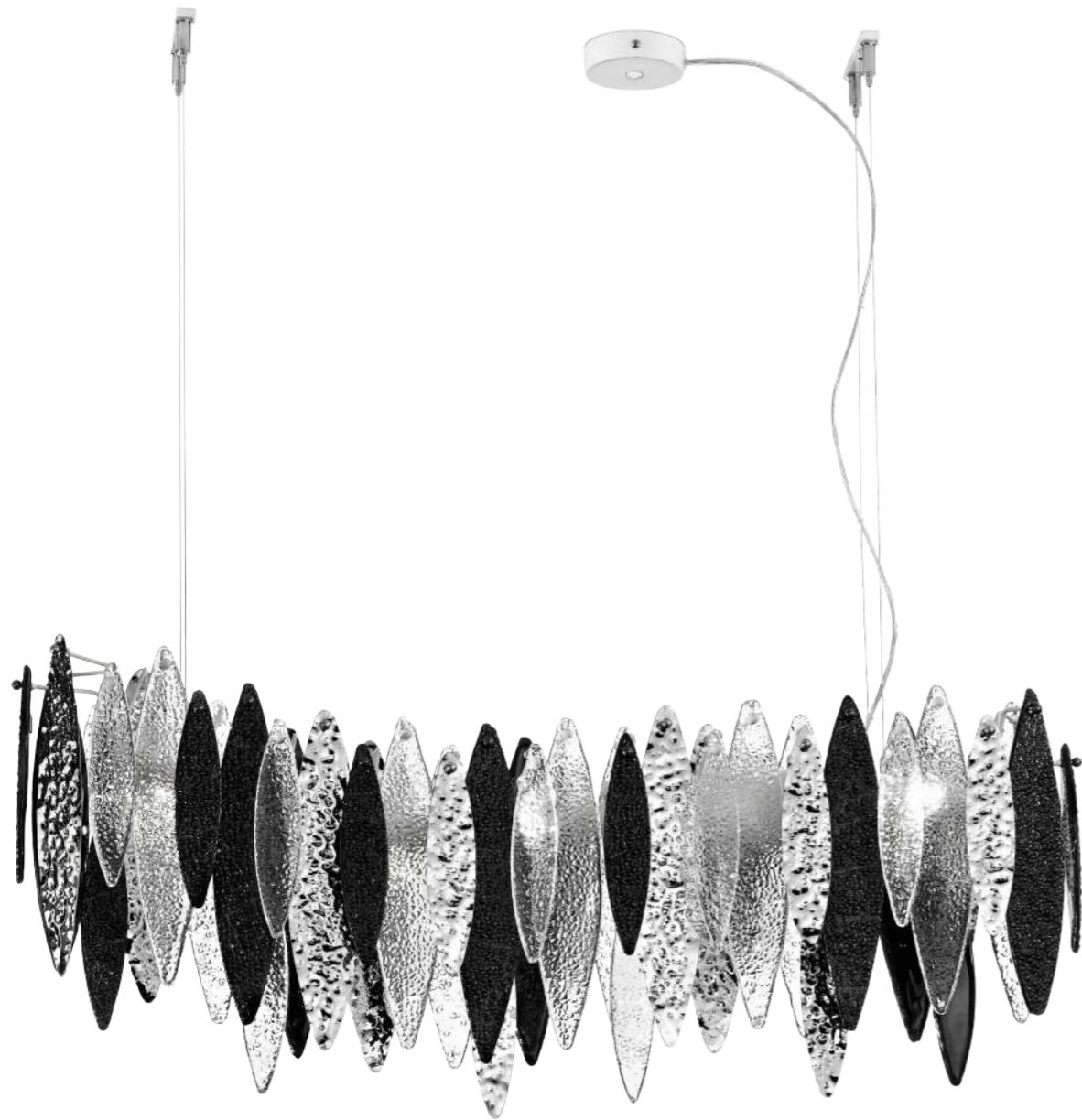

508/10 *sospensione suspension*

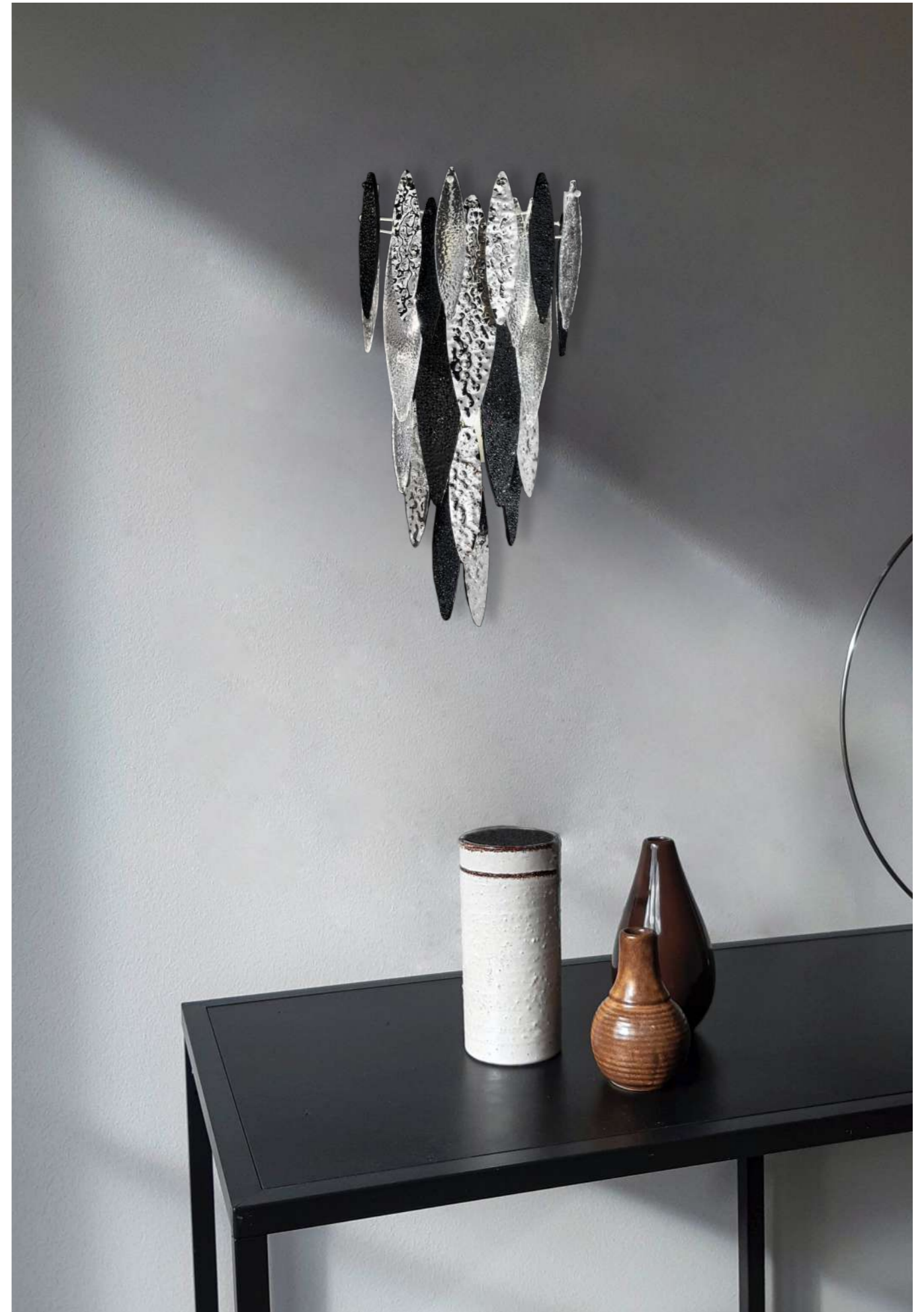

507/6A *applique wall bracket*



507/12 *sospensione suspension*



507/10 *sospensione suspension*



508/80 *sospensione suspension*





507/6A applique wall bracket

507/3A applique wall bracket



507/10PF plafoniera ceiling lamp





507/6P lampada da terra floor lamp

# Ice rain

DESIGN Cristian Feltrin



crystal  
crystal

bianco  
white

crystal, bianco  
e oro chiaro  
crystal, white  
and light gold

crystal  
e oro chiaro  
crystal and  
light gold

crystal, pure steel  
e nero  
crystal, pure steel  
and black

La collezione è disponibile nei seguenti abbinamenti colore:



- CRISTALLO: telaio in metallo avorio lucido con foglie di vetro di Murano trasparenti.
- BIANCO: telaio in avorio lucido con foglie di vetro di Murano bianche.
- MULTICOLORE: telaio in avorio lucido con:
  - A. foglie in vetro di Murano bianco e trasparenti con foglie in metallo oro chiaro effetto martellato.
  - B. foglie in vetro Murano trasparenti con foglie in metallo oro chiaro effetto martellato.
  - C. foglie in vetro di Murano nere e trasparenti con foglie di metallo pure steel effetto martellato.

The collection is available in the following colour combinations:

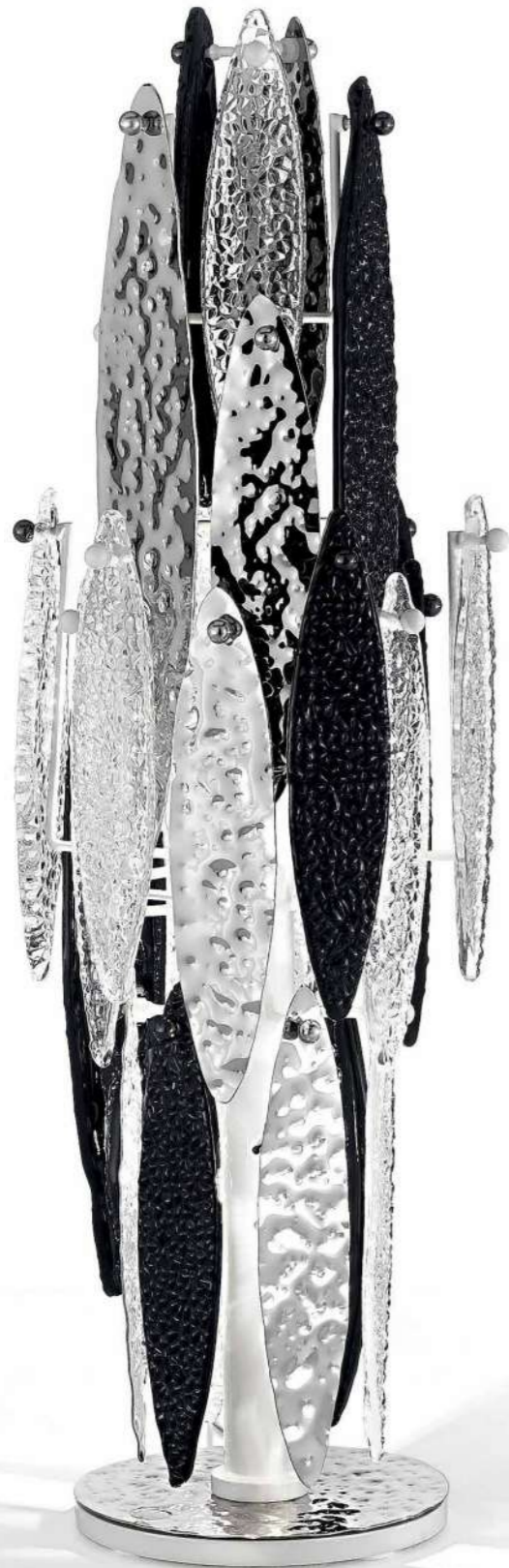
- CRYSTAL: metal frame in soft ivory with leaves of transparent Murano glass.
- WHITE: metal frame in soft ivory with leaves of white Murano glass.
- MULTICOLOR: metal frame in soft ivory with:
  - A. leaves in crystal and white Murano glass with light gold metal leaves with hammered effect.
  - B. leaves in crystal Murano glass with light gold metal leaves with hammered effect.
  - C. leaves in crystal and black Murano glass with pure steel metal leaves with hammered effect.

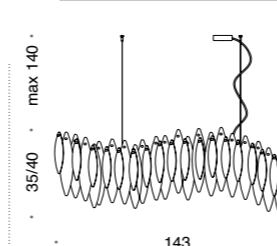

## SOSPENSIONE SUSPENSION

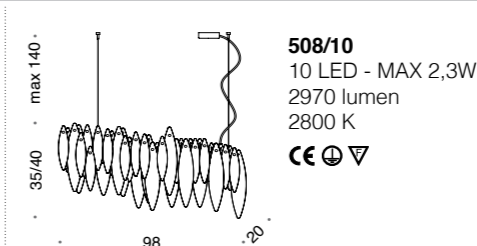
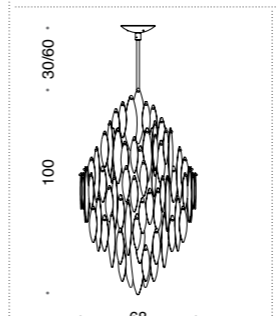
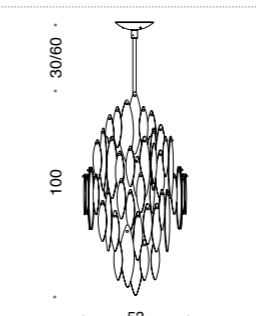
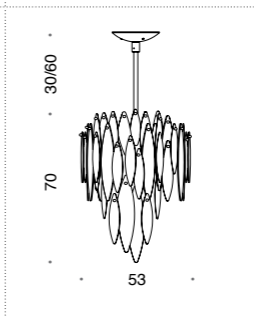
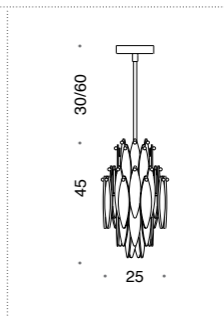
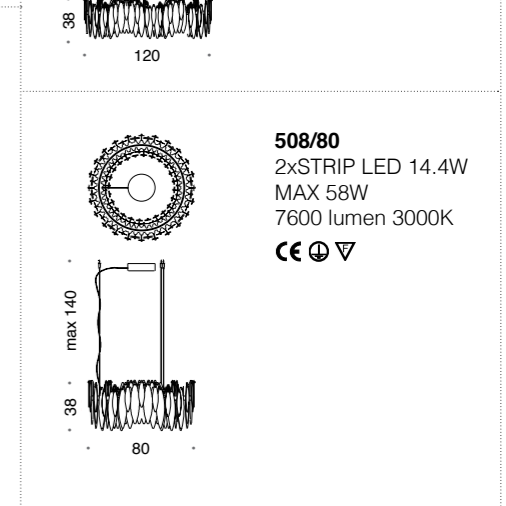
 <p><b>508/12</b> 12 LED - MAX 2,3W 3564 lumen 2800 K CE ⊕ ▽</p>	 <p><b>508/10</b> 10 LED - MAX 2,3W 2970 lumen 2800 K CE ⊕ ▽</p>	 <p><b>508/120</b> 2xSTRIP LED 14.4W MAX 92W 12350 lumen 3000K CE ⊕ ▽</p>		
 <p><b>507/18</b> 18 LED - MAX 2,3W 5346 lumen 2800 K CE ⊕ ▽</p>	 <p><b>507/12</b> 12 LED - MAX 2,3W 3564 lumen 2800 K CE ⊕ ▽</p>	 <p><b>507/10</b> 10 LED - MAX 2,3W 2970 lumen 2800 K CE ⊕ ▽</p>	 <p><b>507/6S</b> 6 LED - MAX 2,3W 1782 lumen 2800 K CE ⊕ ▽</p>	 <p><b>508/80</b> 2xSTRIP LED 14.4W MAX 58W 7600 lumen 3000K CE ⊕ ▽</p>

## PLAFONIERA CEILING LAMP

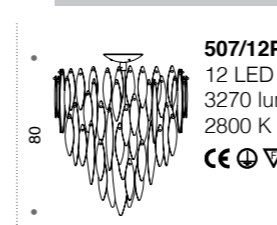
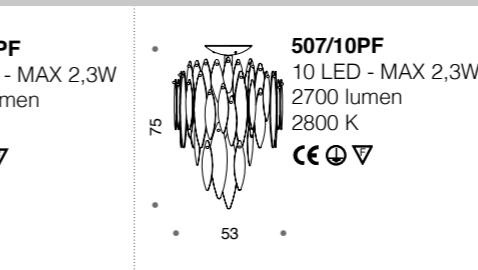
 <p><b>507/12PF</b> 12 LED - MAX 2,3W 3270 lumen 2800 K CE ⊕ ▽</p>	 <p><b>507/10PF</b> 10 LED - MAX 2,3W 2700 lumen 2800 K CE ⊕ ▽</p>
---	---

## APPLIQUE WALL BRACKET

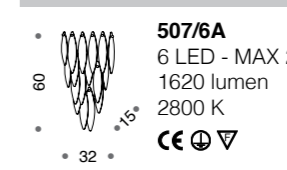
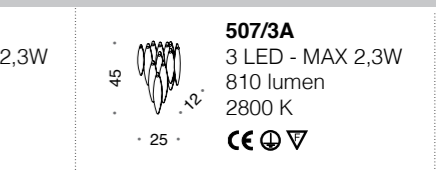
 <p><b>507/6A</b> 6 LED - MAX 2,3W 1620 lumen 2800 K CE ⊕ ▽</p>	 <p><b>507/3A</b> 3 LED - MAX 2,3W 810 lumen 2800 K CE ⊕ ▽</p>
--	---

## LAMPADA DA TAVOLO TABLE LAMP

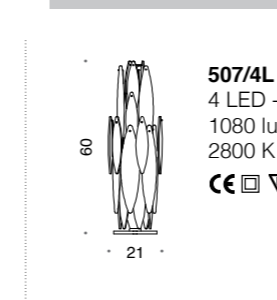
 <p><b>507/4L</b> 4 LED - MAX 2,3W 1080 lumen 2800 K CE ⊕ ▽</p>
--

## LAMPADA DA TERRA FLOOR LAMP

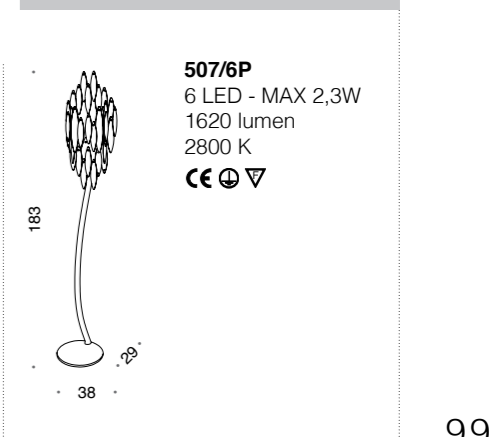
 <p><b>507/6P</b> 6 LED - MAX 2,3W 1620 lumen 2800 K CE ⊕ ▽</p>
--



# Elite

DESIGN *Cristian Feltrin*

596/8+1 *sospensione suspension*

Modello depositato. Registered design.







596/34+3 *sospensione suspension*



596/150 *sospensione suspension*



596/2+1A *applique wall bracket*

# Elite

DESIGN Cristian Feltrin

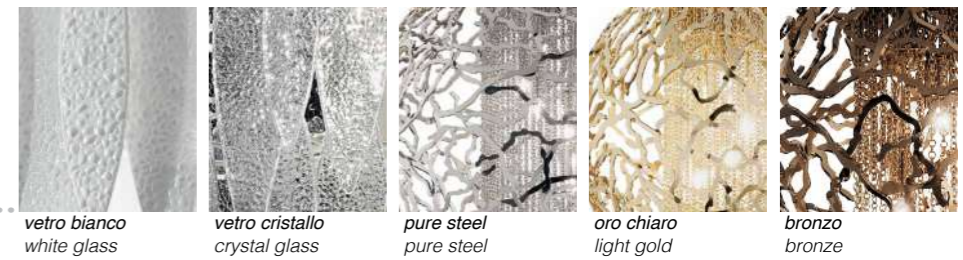

vetro bianco  
white glass

vetro cristallo  
crystal glass

pure steel  
pure steel

oro chiaro  
light gold

bronzo  
bronze



Telaio in metallo disponibile nelle seguenti finiture:

- pure steel
- oro chiaro
- bronzo

Le foglie in vetro di Murano sono disponibili nei colori:

- bianco
- trasparente
- nero

Metal frame available in the following finishes:

- pure steel
- light gold
- bronze

The leaves, in Murano glass, are available in the colors:

- white
- crystal
- black

## SOSPENSIONE SUSPENSION

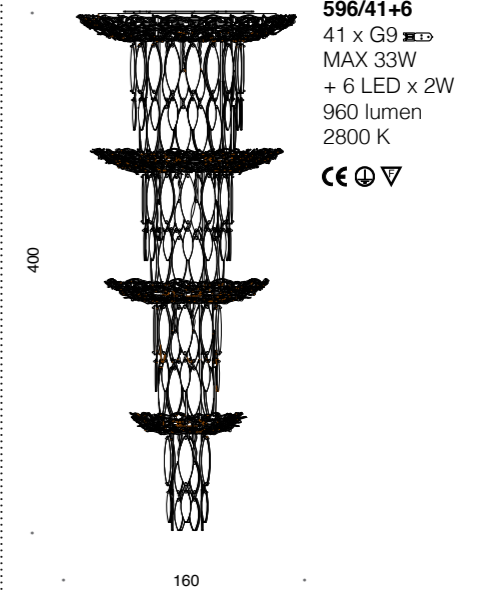
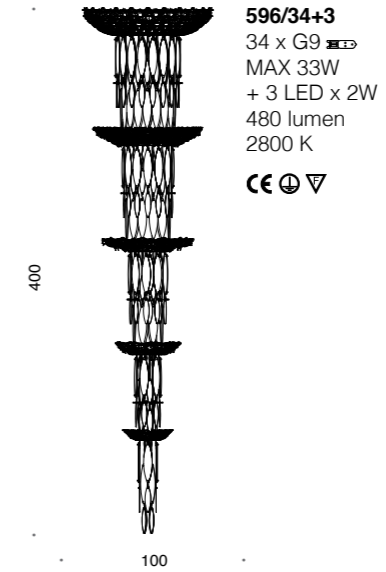
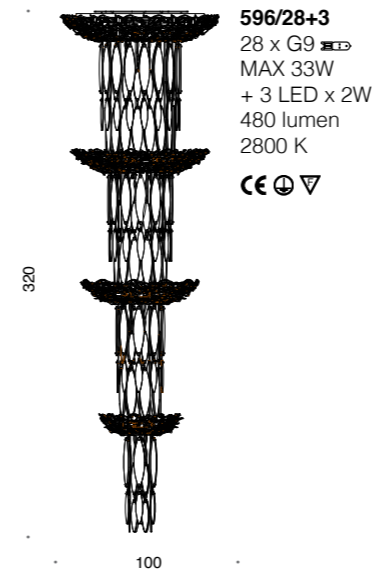

Disponibile realizzazioni su misura.  
Custom-made sizes available.

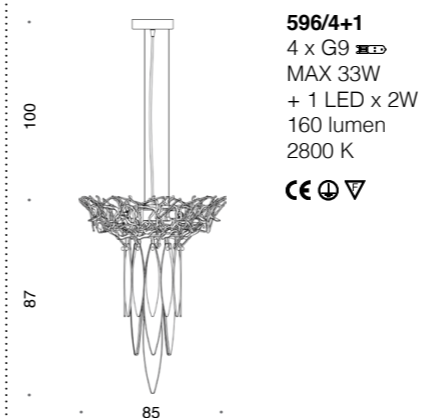
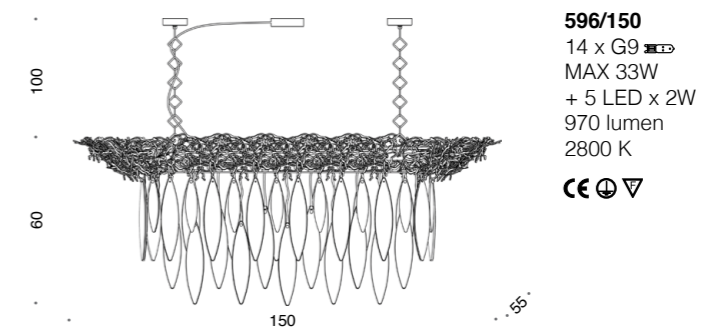
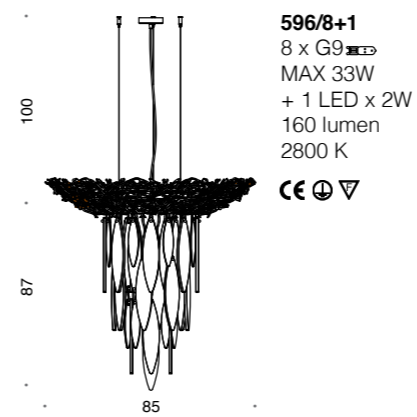

## PLAFONIERA CEILING LAMP

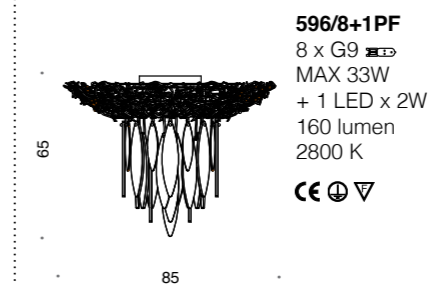

## APPLIQUE WALL BRACKET

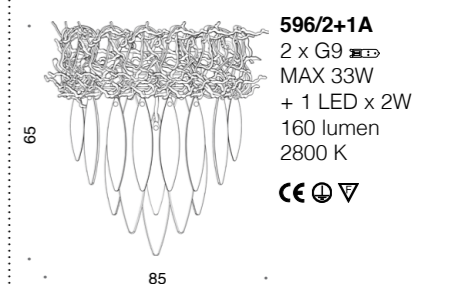



# Groovy

DESIGN *Cristian Feltrin*

Modello depositato. Registered design.

464/12 *sospensione suspension*



463/1P *lampada da terra floor lamp*



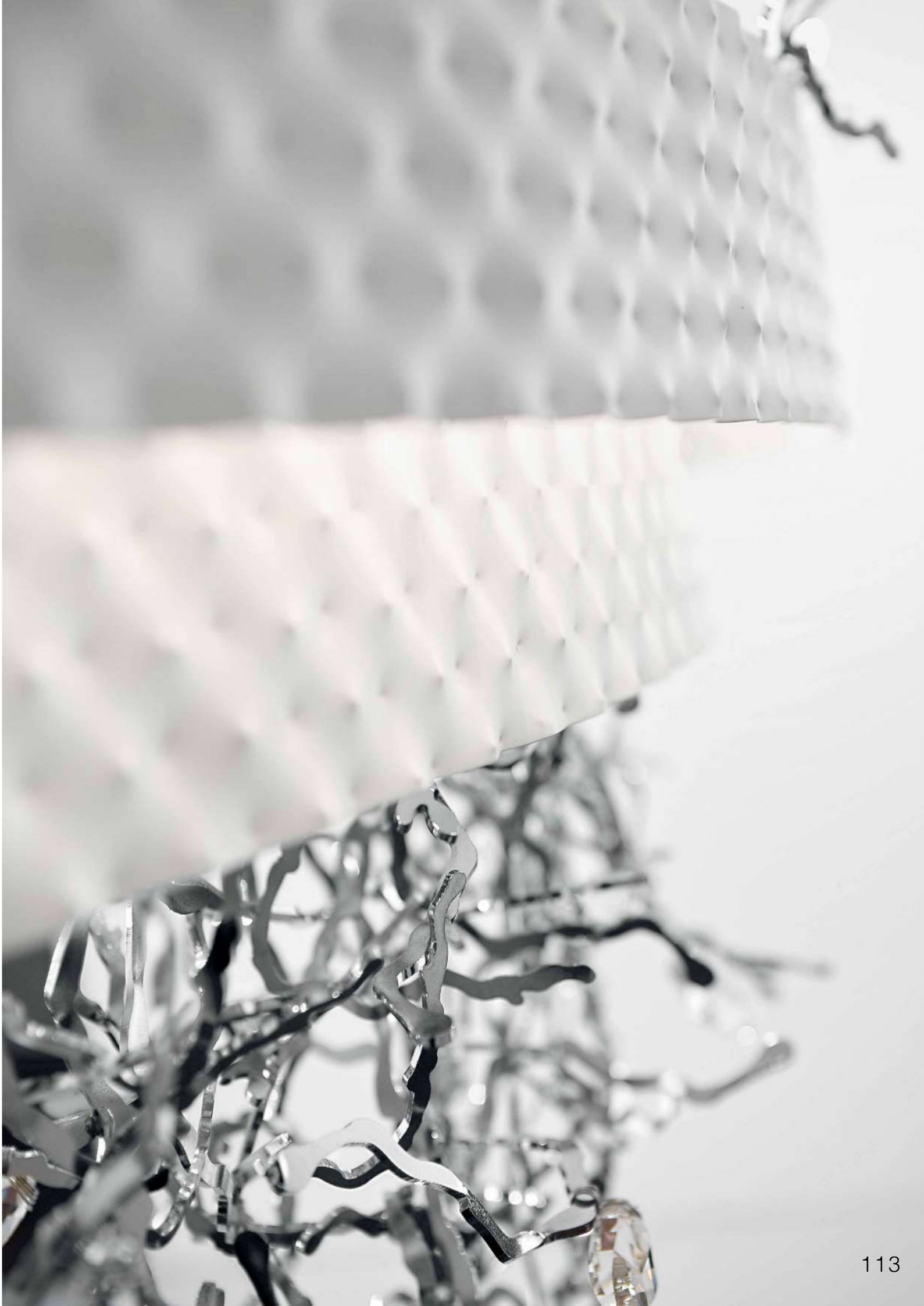

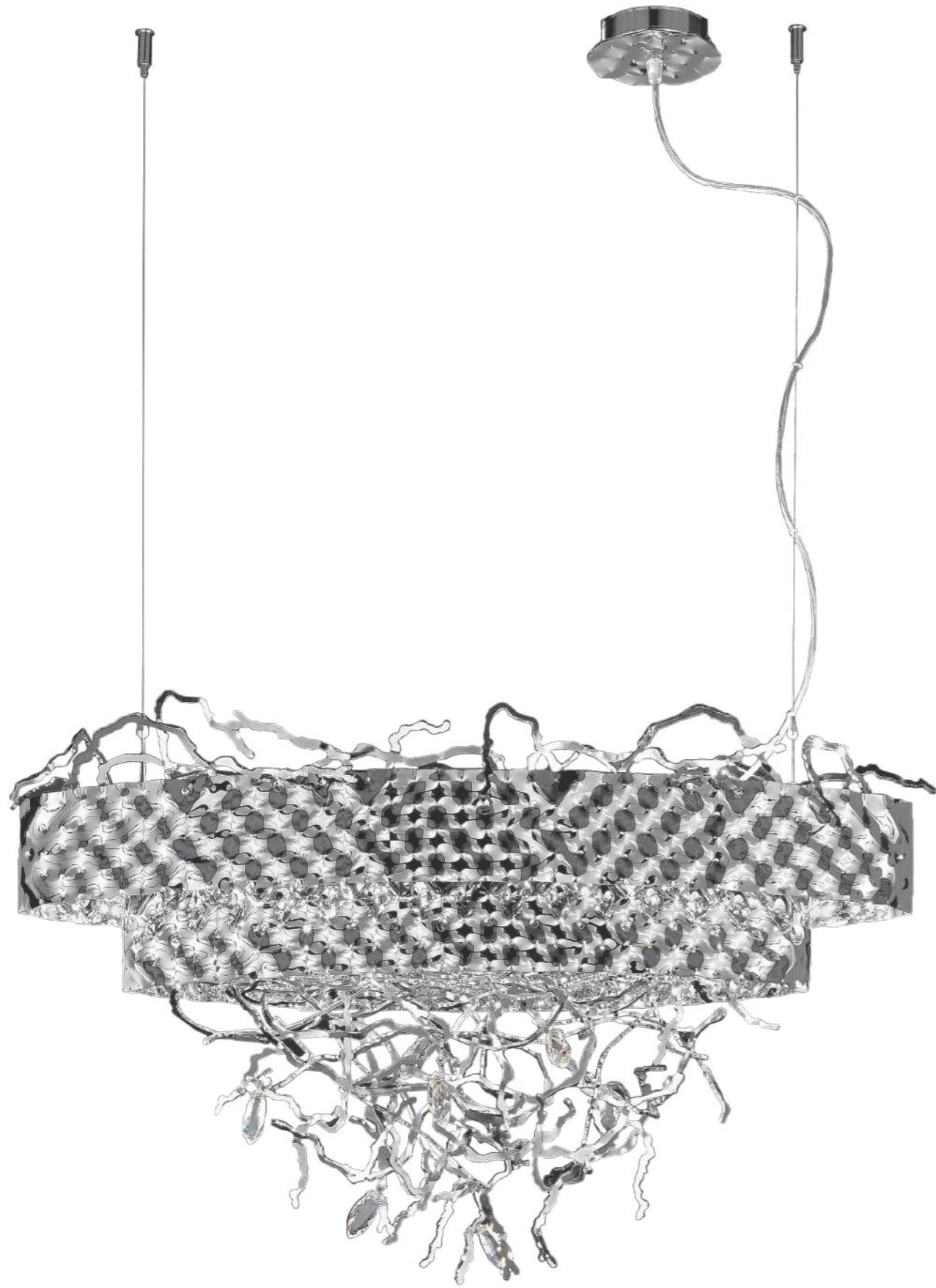

464/6 *sospensione suspension*



463/1A *applique wall bracket*



463/12 *sospensione suspension*



463/10 *sospensione suspension*



463/6 *sospensione suspension*



463/1L *lampada da tavolo table lamp*



463/8PF plafoniera ceiling lamp



463/1A applique wall bracket

# Groovy

DESIGN Cristian Feltrin

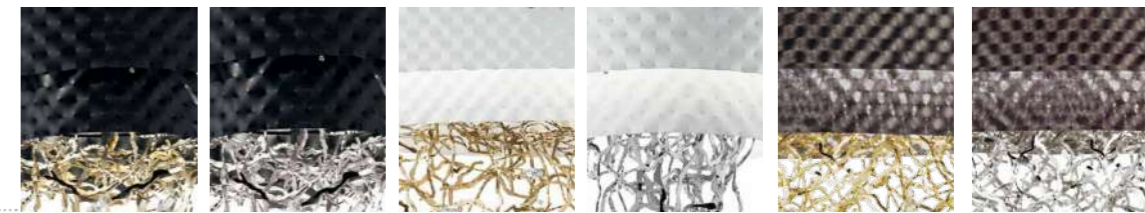

nero velluto e oro chiaro  
velvet black and light gold

nero velluto e pure steel  
velvet black and pure steel

bianco velluto e oro chiaro  
velvet white and light gold

bianco velluto e pure steel  
velvet white and pure steel

foglia nera e oro chiaro  
black leaf and light gold

foglia nera e pure steel  
black leaf and pure steel

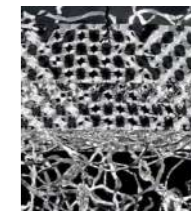

pure steel  
pure steel



oro chiaro  
light gold

La collezione è disponibile nei seguenti abbinamenti colore:

- fascia bianco velluto e rami pure steel o oro chiaro
- fascia nero velluto e rami pure steel o oro chiaro
- fascia foglia nera e rami pure steel o oro chiaro
- tutto pure steel
- tutto oro chiaro

Nell'applicare i diffusori sono in vetro plexiglass satinato.

La collezione è decorata con cristalli trasparenti.

The collection is available in the following colour combinations:

- velvet white band and pure steel or light gold branches
- velvet black band and pure steel or light gold branches
- black leaf band and pure steel or light gold branches
- entirely pure steel
- entirely light gold

The diffusers for the wall lamps are in satin Plexiglass.

The collection is decorated with transparent crystals.

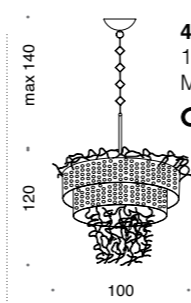
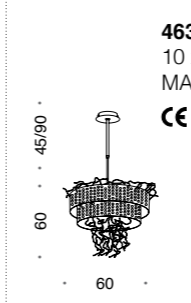
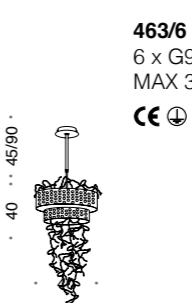
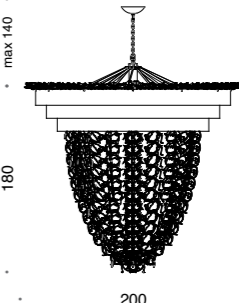
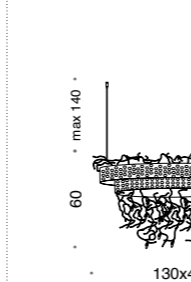
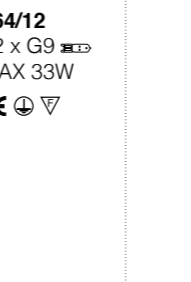

## SOSPENSIONE SUSPENSION

 <p><b>463/12</b> 12 x G9 MAX 33W CE ⊕ ▽</p>	 <p><b>463/10</b> 10 x G9 MAX 33W CE ⊕ ▽</p>	 <p><b>463/6</b> 6 x G9 MAX 33W CE ⊕ ▽</p>	 <p><b>463/200x180</b> 18 x G9 MAX 33W 6x GU10 MAX 35W CE ⊕ ▽</p>
 <p><b>464/12</b> 12 x G9 MAX 33W CE ⊕ ▽</p>	 <p><b>464/6</b> 6 x G9 MAX 33W CE ⊕ ▽</p>	<p>Disponibile realizzazioni su misura. Custom-made sizes available.</p>	

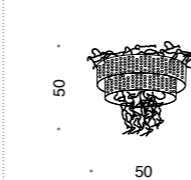
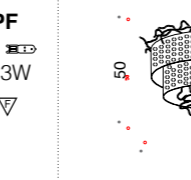
## PLAFONIERA CEILING LAMP

 <p><b>463/8PF</b> 8 x G9 MAX 33W CE ⊕ ▽</p>	 <p><b>463/10PF</b> 10 x G9 MAX 33W CE ⊕ ▽</p>
---	---

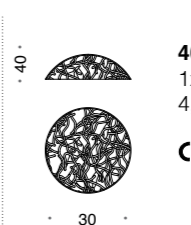
## FARETTO SPOT LIGHT

 <p><b>463/30SPOT</b> 1xGU10 LED 4,6W 2700K CE ⊕ ▽</p>	 <p><b>463/20SPOT</b> 1xGU10 LED 4,6W 2700K CE ⊕ ▽</p>
---	---

## LAMPADA DA TERRA FLOOR LAMP



**463/1P**  
1 x E27  
MAX 77W  
CE ⊕ ▽

## LAMPADA DA TAVOLO TABLE LAMP

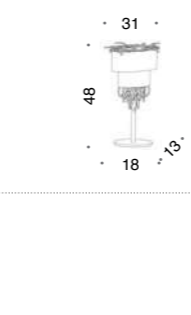

**463/1L**  
1 x E14  
MAX 60W  
CE ⊕ ▽

## APPLIQUE WALL LAMP

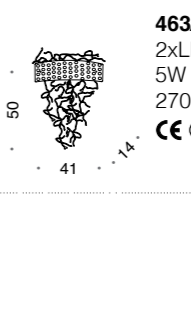
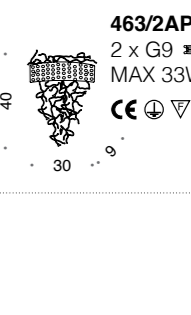
 <p><b>463/1A</b> 2xLED 5W 1150 lumen 2700K CE ⊕ ▽</p>	 <p><b>463/2AP</b> 2 x G9 MAX 33W CE ⊕ ▽</p>
---	---



464/12 sospensione suspension



# Weave

DESIGN *Cristian Feltrin*

Modello depositato. Registered design.



513/8 *sospensione suspension*









511/6 *sospensione suspension*



511/3 *sospensione suspension*

511/4 *sospensione suspension*



513/6PF plafoniera ceiling lamp







511/2A applique wall bracket



511/4L lampada da tavolo table lamp



511/1L lampada da tavolo table lamp



591/1L lampada da tavolo table lamp



590/1L lampada da tavolo table lamp

# WEAVE

DESIGN IDL staff



pure steel  
pure steel

oro chiaro  
light gold

bronzo scuro  
dark bronze

Paralume disponibili in:  
Lampshade available in:



iuta scuro  
dark jute

iuta chiaro  
light jute

chinette avorio  
ivory chinette

chinette tortora  
dove grey chinette

Telaio in metallo disponibile nelle finiture:

- pure steel con catene nichel
- oro chiaro con catene dorate
- bronzo con catene bronzo

The metal frame is available in the finishes:

- pure steel with nickel chains
- light gold with golden chains
- bronze with bronze chains

Per le lampade da tavolo i paralumi in tessuto sono in:

- iuta chiaro o scuro
- chinette avorio o tortora









For the table lamps the lampshades in fabric are in:

- light or dark jute
- ivory or dove grey chinette

Per le lampade con paralumi in metallo le finiture sono stesse del telaio.

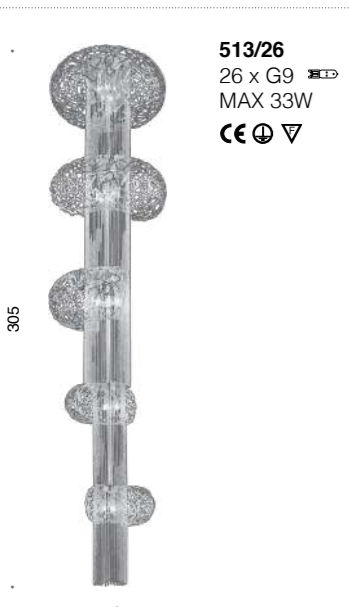
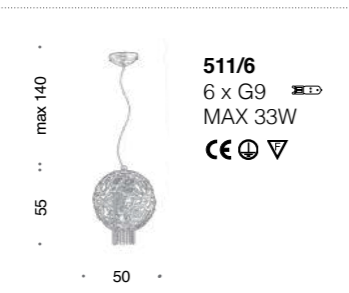
For the table lamps with metal lampshades the finishes are the same of the frame.

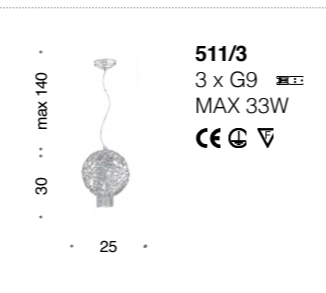
## SOSPENSIONE SUSPENSION

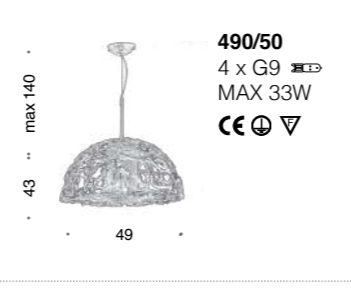
 <p><b>513/16</b> 16 x G9 MAX 33W CE ⊕ ▽</p> <p>max 140 59 120</p>	 <p><b>513/12</b> 12 x G9 MAX 33W CE ⊕ ▽</p> <p>max 140 52 100</p>	 <p><b>513/8</b> 8 x G9 MAX 33W CE ⊕ ▽</p> <p>max 140 36 70</p>	 <p><b>513/6</b> 6 x G9 MAX 33W CE ⊕ ▽</p> <p>max 140 30 50</p>
 <p><b>513/26</b> 26 x G9 MAX 33W CE ⊕ ▽</p> <p>305 70</p>	 <p><b>511/6</b> 6 x G9 MAX 33W CE ⊕ ▽</p> <p>max 140 55 50</p>	 <p><b>511/4</b> 4 x G9 MAX 33W CE ⊕ ▽</p> <p>max 140 40 35</p>	 <p><b>511/3</b> 3 x G9 MAX 33W CE ⊕ ▽</p> <p>max 140 30 25</p>
 <p><b>490/70</b> 6 x G9 MAX 33W CE ⊕ ▽</p> <p>max 140 58 70</p>	 <p><b>490/50</b> 4 x G9 MAX 33W CE ⊕ ▽</p> <p>max 140 43 49</p>		



Disponibile realizzazioni su misura.  
Custom-made sizes available.





**514/6**  
6 x G9  
MAX 33W  
CE ⊕ ▽

max 202  
80/110

## PLAFONIERA CEILING LAMP

 <p><b>513/8PF</b> 8 x G9 MAX 33W CE ⊕ ▽</p> <p>36 70</p>	 <p><b>513/6PF</b> 6 x G9 MAX 33W CE ⊕ ▽</p> <p>30 50</p>
--	--

## APPLIQUE WALL BRACKET

 <p><b>513/3A</b> 3 x G9 MAX 33W CE ⊕ ▽</p> <p>27 35</p>	 <p><b>511/2A</b> 2 x G9 MAX 33W CE ⊕ ▽</p> <p>30 25</p>
---	---

## LAMPADA DA TAVOLO TABLE LAMP

 <p><b>511/1L</b> 1 x E27 MAX 77W CE ⊕ ▽</p> <p>40 62 25</p>	 <p><b>511/4L</b> 4 x G9 MAX 33W CE ⊕ ▽</p> <p>53 50</p>	 <p><b>511/3L</b> 3 x G9 MAX 33W CE ⊕ ▽</p> <p>36 35</p>	 <p><b>511/2L</b> 2 x G9 MAX 33W CE ⊕ ▽</p> <p>26 25</p>
 <p><b>590/1L</b> 1 x E27 MAX 77W CE ⊕ ▽</p> <p>40 62 25 20</p>	 <p><b>591/1L</b> 1 x E27 MAX 77W CE ⊕ ▽</p> <p>40 64 20</p>		



660/10 *sospensione suspension*

# Tribù

DESIGN *Cristian Feltrin*

Modello depositato. Registered design.







660/2A applique wall bracket



661/2L lampada da tavolo table lamp



661/1A applique wall bracket

661/2A applique wall bracket



661/2A applique wall bracket



660/1A applique wall bracket



660/2A applique wall bracket

# TRIBU'

DESIGN Cristian Feltrin

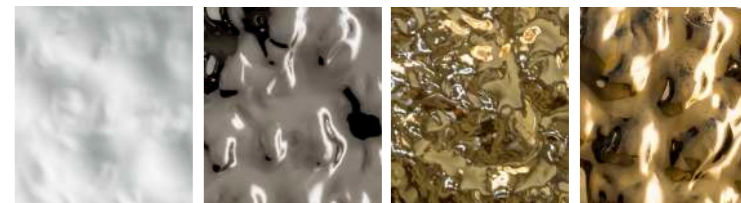

Bianco velluto  
velvet white

pure steel  
pure steel

oro chiaro  
light gold

oro antico lucido  
glossy antique gold

Il telaio in metallo è disponibile nelle seguenti finiture:

- oro antico lucido
- oro chiaro
- pure steel
- bianco velluto

Metal frame is available in the following finishes:

- glossy antique gold
- light gold
- pure steel
- velvet white

Vetro di Murano trasparente martellato.

Hammered transparent Murano glass.



## SOSPENSIONE SUSPENSION

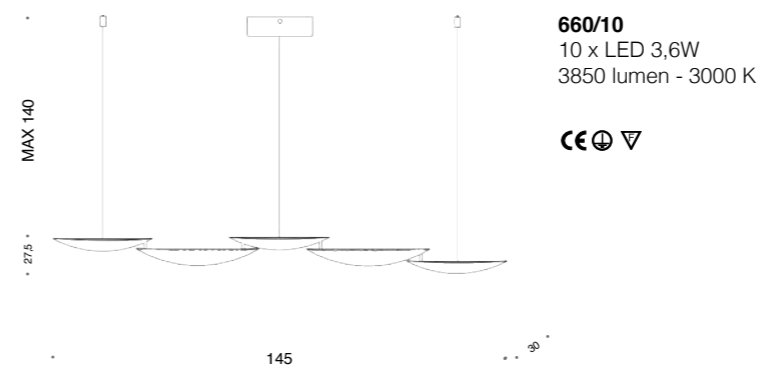

## LAMPADA DA TAVOLO TABLE LAMP

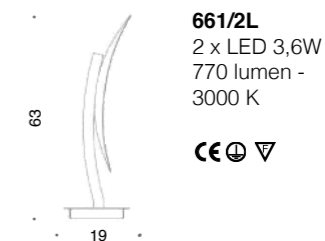

## APPLIQUE WALL BRACKET



661/2A applique wall bracket



# Chrysalis

DESIGN *Cristian Feltrin*

Modello depositato. Registered design.

**448/5+3** *sospensione suspension*



**448/6+3** *sospensione suspension*



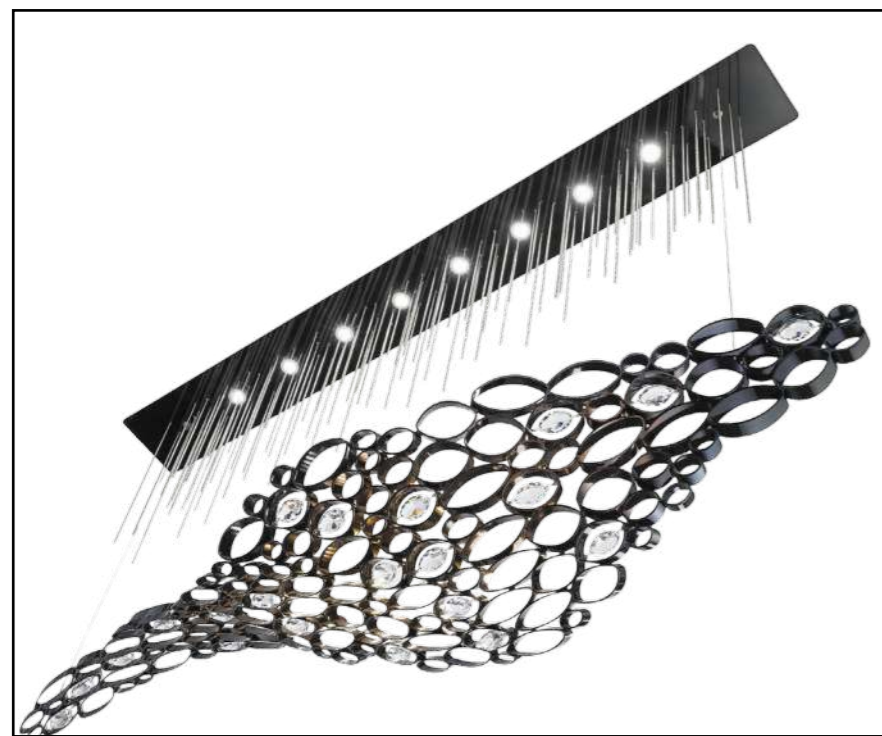

448/8SLED *sospensione suspension*







448/27 sospensione suspension

Disponibili realizzazioni su misura. Custom made sizes available.





448/8 *sospensione suspension*



448/3PF *sospensione suspension*

448/5+3PF *sospensione suspension*



448/SPOT plafoniera ceiling lamp

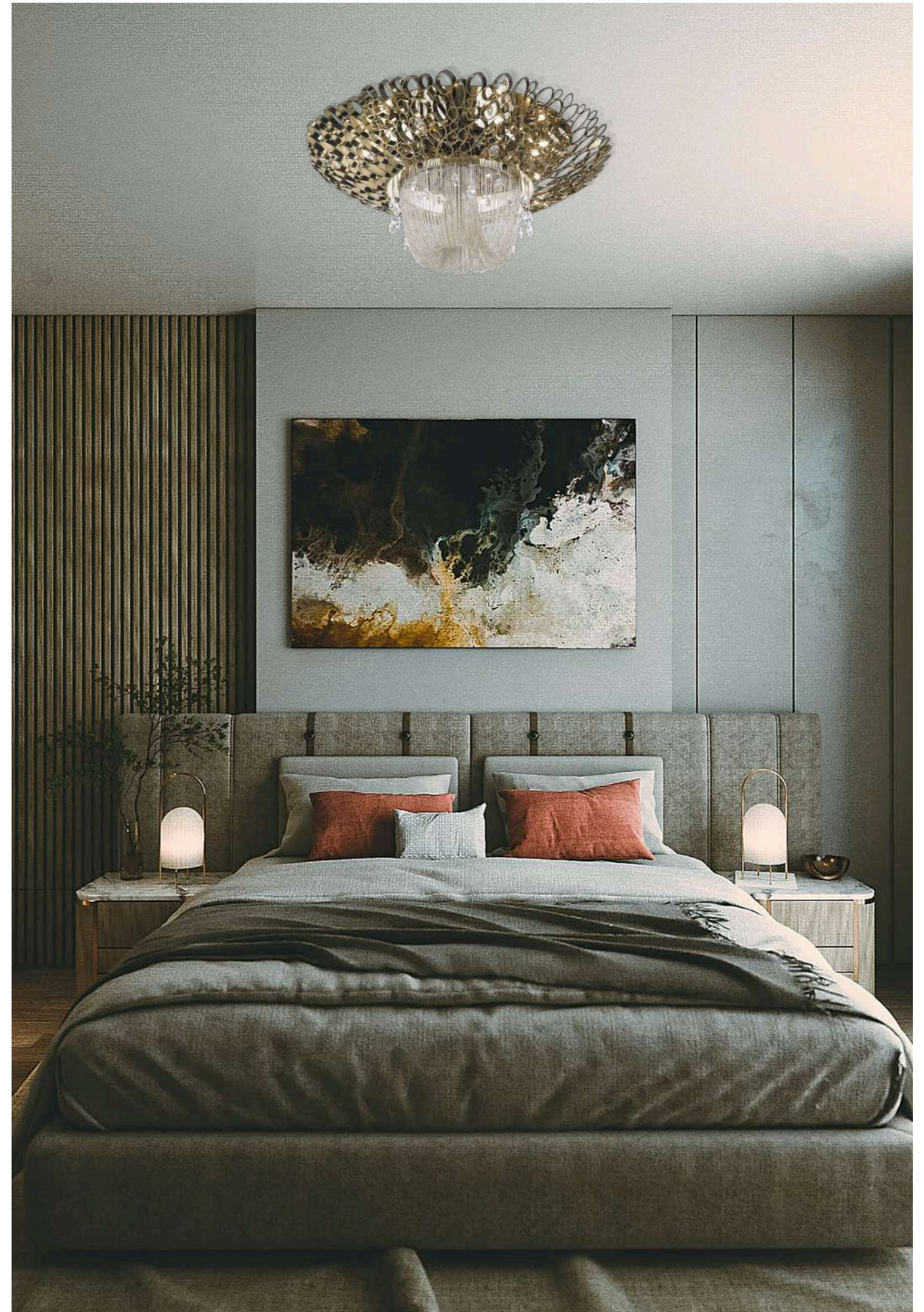

448/84PF plafoniera ceiling lamp



448/3ASX *applique wall bracket*



448/3ADX *applique wall bracket*



448/3AG *applique wall bracket*



448/1LG lampada da tavolo table lamp



448/3L lampada da tavolo table lamp

448/5L lampada da tavolo table lamp



448/6+5P lampada da terra floor lamp



# Chrysalis

DESIGN Cristian Feltrin



avorio lucido  
soft ivory



oro chiaro  
light gold



pure steel  
pure steel



black aubergine  
black aubergine



nichel nero  
black nickel



paralume plissé avorio  
ivory plissé lampshade

## SOSPENSIONE SUSPENSION

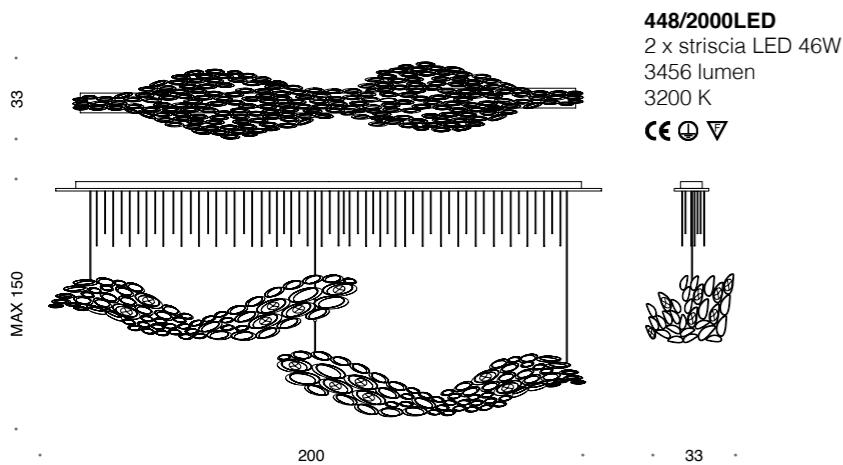

**448/2000LED**  
2 x striscia LED 46W  
3456 lumen  
3200 K  
CE ⊕ ▽

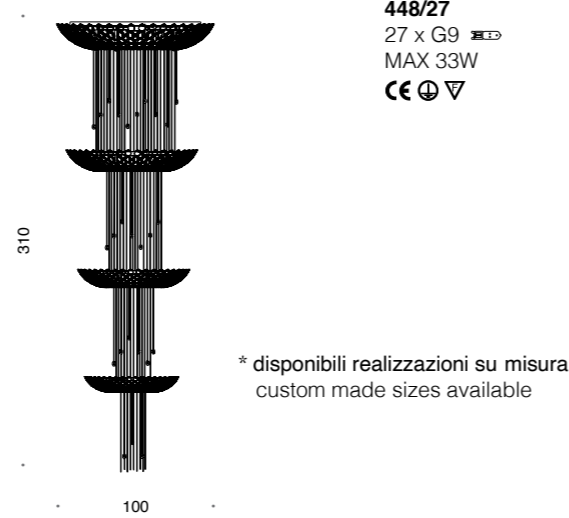

**448/27**  
27 x G9  
MAX 33W  
CE ⊕ ▽

\* disponibili realizzazioni su misura  
custom made sizes available

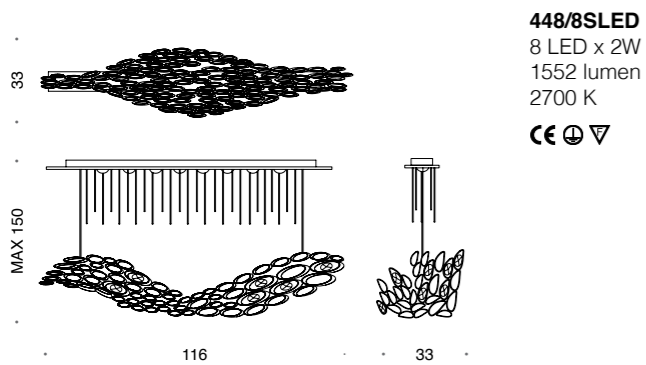

**448/8SLED**  
8 LED x 2W  
1552 lumen  
2700 K  
CE ⊕ ▽

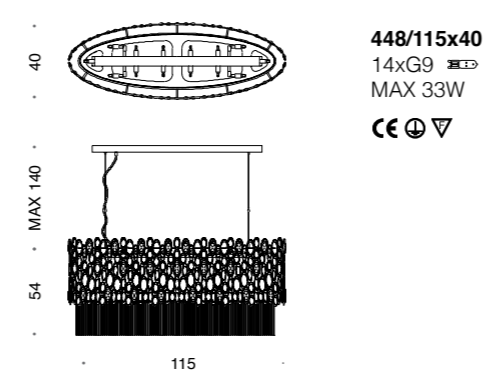

**448/115x40**  
14xG9  
MAX 33W  
CE ⊕ ▽

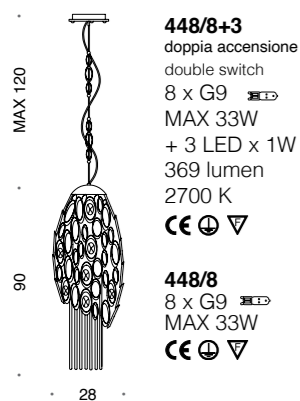

**448/8+3**  
doppia accensione  
double switch  
8 x G9  
MAX 33W  
+ 3 LED x 1W  
369 lumen  
2700 K  
CE ⊕ ▽

**448/8**  
8 x G9  
MAX 33W  
CE ⊕ ▽

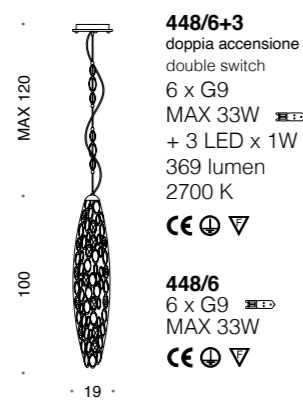

**448/6+3**  
doppia accensione  
double switch  
6 x G9  
MAX 33W  
+ 3 LED x 1W  
369 lumen  
2700 K  
CE ⊕ ▽

**448/6**  
6 x G9  
MAX 33W  
CE ⊕ ▽

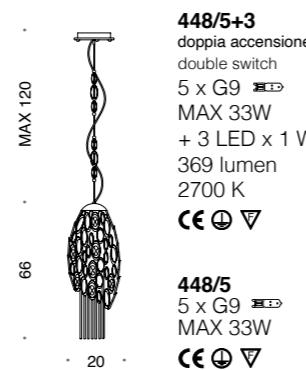

**448/5+3**  
doppia accensione  
double switch  
5 x G9  
MAX 33W  
+ 3 LED x 1W  
369 lumen  
2700 K  
CE ⊕ ▽

**448/5**  
5 x G9  
MAX 33W  
CE ⊕ ▽

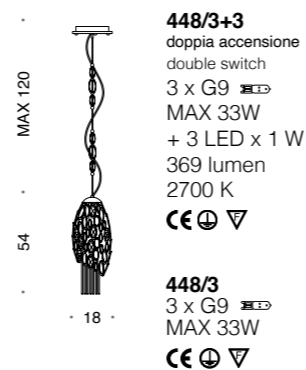

**448/3+3**  
doppia accensione  
double switch  
3 x G9  
MAX 33W  
+ 3 LED x 1W  
369 lumen  
2700 K  
CE ⊕ ▽

**448/3**  
3 x G9  
MAX 33W  
CE ⊕ ▽

Telaio in metallo, disponibile nelle seguenti finiture:

- oro chiaro
- pure steel
- avorio lucido
- black aubergine
- nichel nero

Catene pendenti in rame con finitura nichel satinato o dorate.  
Negli articoli 448/6+3 (448/6), 448//6+5P (448/6P) gli articoli sono forniti di serie senza catene pendenti.

La collezione è decorata con cristalli trasparenti

Metal frame, available in the following finishes:

- light gold
- pure steel
- soft ivory
- black aubergine
- black nickel

Copper pendant chains in satin nickel or golden finish.  
Articles 448/6+3 (448/6), 448/6+5P (448/6P) are supplied standard without pendant chains.

The collection is decorated with transparent crystals

## PLAFONIERA CEILING LAMP

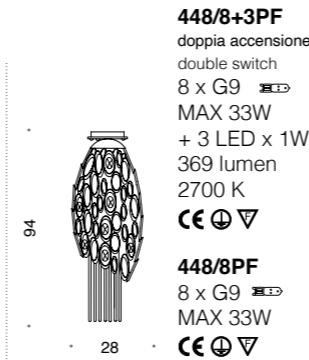

**448/8+3PF**  
doppia accensione  
double switch  
8 x G9  
MAX 33W  
+ 3 LED x 1W  
369 lumen  
2700 K  
CE ⊕ ▽

**448/8PF**  
8 x G9  
MAX 33W  
CE ⊕ ▽



**448/5+3PF**  
doppia accensione  
double switch  
5 x G9  
MAX 33W  
+ 3 LED x 1W  
369 lumen  
2700 K  
CE ⊕ ▽

**448/5PF**  
5 x G9  
MAX 33W  
CE ⊕ ▽

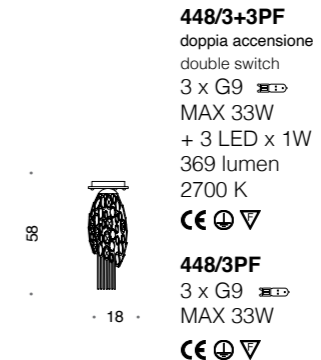

**448/3+3PF**  
doppia accensione  
double switch  
3 x G9  
MAX 33W  
+ 3 LED x 1W  
369 lumen  
2700 K  
CE ⊕ ▽

**448/3PF**  
3 x G9  
MAX 33W  
CE ⊕ ▽

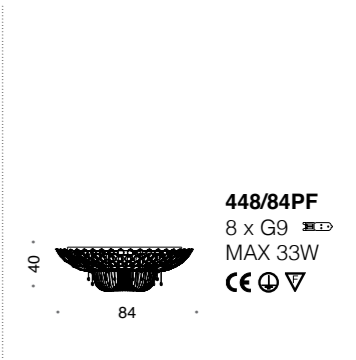

**448/84PF**  
8 x G9  
MAX 33W  
CE ⊕ ▽

## APPLIQUE WALL BRACKET

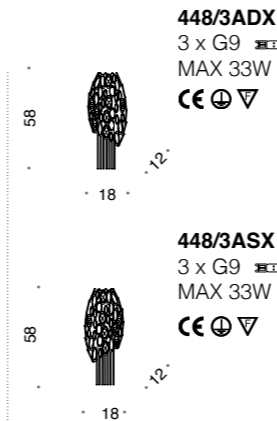

**448/3ADX**  
3 x G9  
MAX 33W  
CE ⊕ ▽

**448/3ASX**  
3 x G9  
MAX 33W  
CE ⊕ ▽



**448/3AG**  
3 x G9  
MAX 33W  
CE ⊕ ▽

## FARETTO SPOT SPOT LIGHT

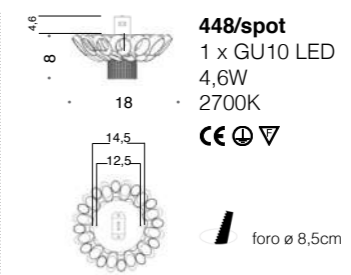

**448/spot**  
1 x GU10 LED  
4,6W  
2700K  
CE ⊕ ▽

foro ø 8,5cm

## LAMPADA DA TAVOLO TABLE LAMP

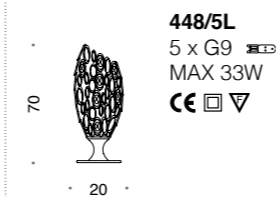

**448/5L**  
5 x G9  
MAX 33W  
CE ⊕ ▽

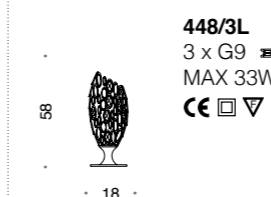

**448/3L**  
3 x G9  
MAX 33W  
CE ⊕ ▽

## LAMPADA DA TAVOLO TABLE LAMP

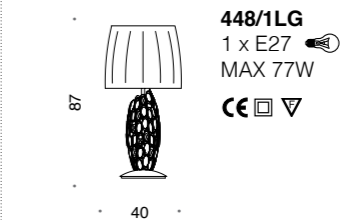

**448/1LG**  
1 x E27  
MAX 77W  
CE ⊕ ▽

## LAMPADA DA TERRA FLOOR LAMP

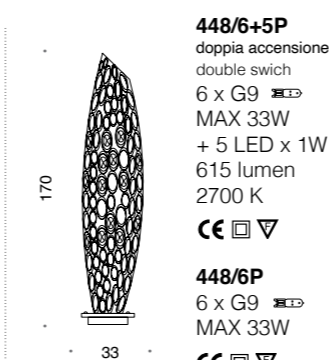

**448/6+5P**  
doppia accensione  
double switch  
6 x G9  
MAX 33W  
+ 5 LED x 1W  
615 lumen  
2700 K  
CE ⊕ ▽

**448/6P**  
6 x G9  
MAX 33W  
CE ⊕ ▽



# Leaves

DESIGN *Cristian Feltrin*

Modello depositato. Registered design.

605/16 sospensione suspension





605/16 *sospensione suspension*









605/5A applique wall bracket



# LEAVES

DESIGN Cristian Feltrin

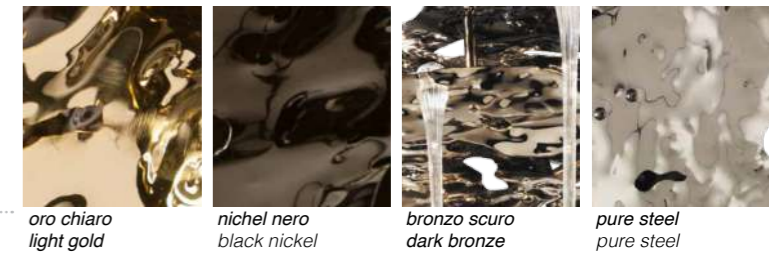

oro chiaro  
light gold

nicel nero  
black nickel

bronzo scuro  
dark bronze

pure steel  
pure steel

Telaio in metallo, disponibile nelle seguenti finiture:

- oro chiaro
- pure steel
- nichel nero
- bronzo scuro





Decorato con vetro di Murano trasparente.

Metal frame, available in the following finishes:

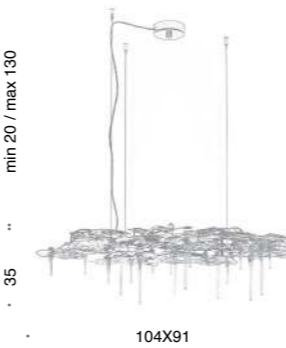

- light gold
- pure steel
- black nickel
- dark bronze

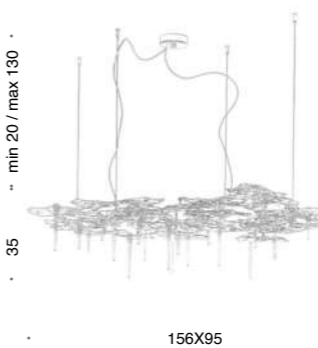
Decorated with transparent Murano glass

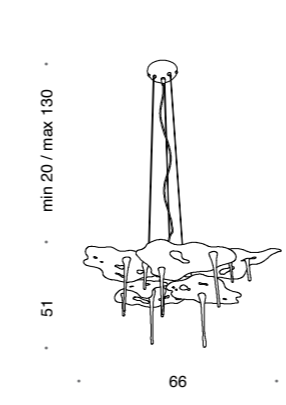
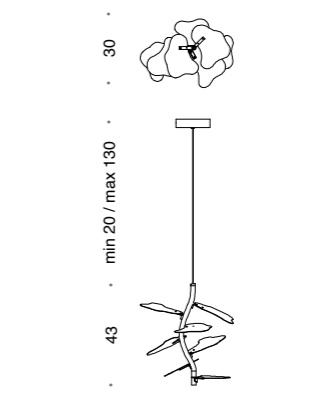
## SOSPENSIONE SUSPENSION

 <p>min 20 / max 130</p> <p>35</p> <p>104X91</p>	<p><b>605/10</b> 5 x G9 MAX 33W and 5 LED x 1W 600 lumen 2800K CE ⊕ ▽</p> <p><b>606/10</b></p>  <p>Single fastening</p>	 <p>min 20 / max 130</p> <p>35</p> <p>156X95</p>	<p><b>605/16</b> 8 x G9 MAX 33W and 8 LED x 1W 960 lumen 2800K CE ⊕ ▽</p> <p><b>606/16</b></p>  <p>Single fastening</p>
 <p>min 20 / max 130</p> <p>51</p> <p>66</p>	<p><b>605/8</b> 8 LED x 2,3W 1200 lumen 2800K CE ⊕ ▽</p>	 <p>30</p> <p>min 20 / max 130</p> <p>43</p> <p>33</p>	<p><b>605/1S</b> 1 LED x 2,3W 150 lumen 2800K CE ⊕ ▽</p>

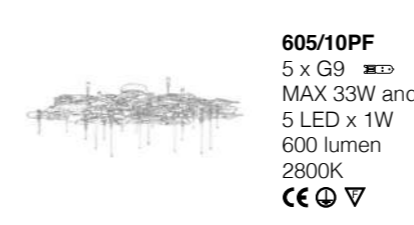
## PLAFONIERA CEILING LAMP

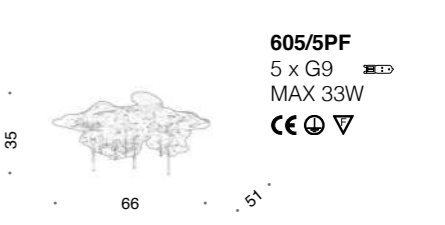
 <p>35</p> <p>104X91</p>	<p><b>605/10PF</b> 5 x G9 MAX 33W and 5 LED x 1W 600 lumen 2800K CE ⊕ ▽</p>	 <p>35</p> <p>156X95</p>	<p><b>605/16PF</b> 8 x G9 MAX 33W and 8 LED x 1W 960 lumen 2800K CE ⊕ ▽</p>	 <p>35</p> <p>66</p> <p>51</p>	<p><b>605/5PF</b> 5 x G9 MAX 33W CE ⊕ ▽</p>
---	---	---	---	---	---

## APPLIQUE WALL BRACKET

 <p>66</p> <p>51</p>	<p><b>605/5A</b> 5 x G9 MAX 33W CE ⊕ ▽</p>
---	--

605/8 sospensione suspension



# Amalgama

DESIGN *Cristian Feltrin*

Modello depositato. Registered design.





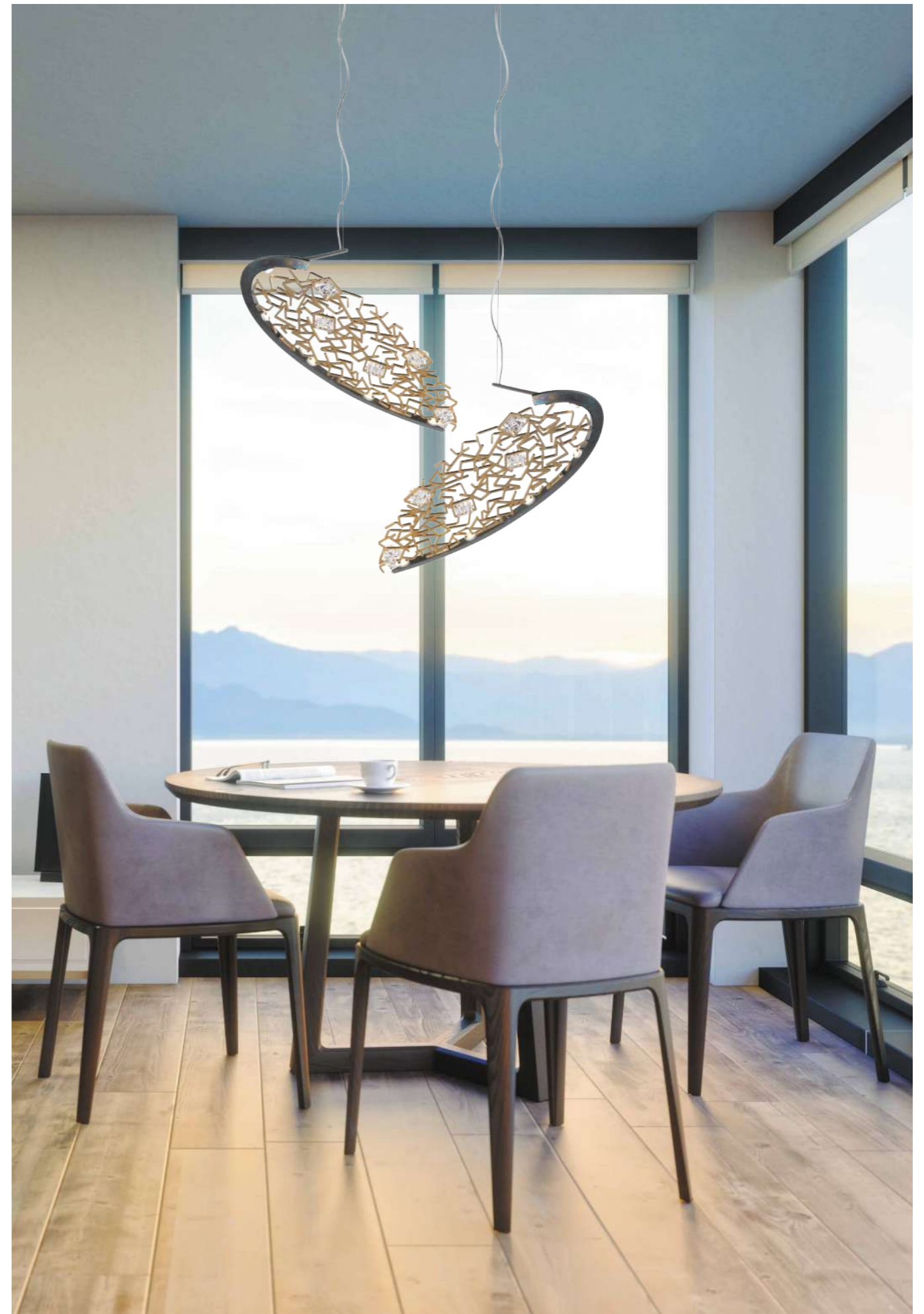





647/4A applique wall bracket



646/12PF plafoniera ceiling lamp



# AMALGAMA

DESIGN Cristian Feltrin

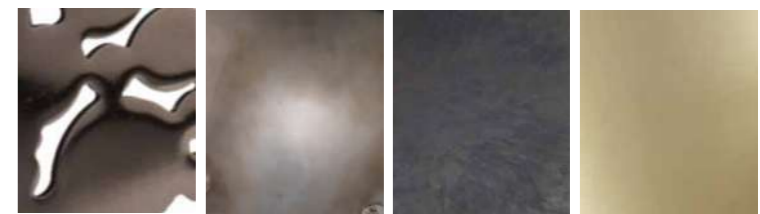

black aubergine  
black aubergine  
corten nuvolato  
cloudy corten  
brunito corten  
burnished corten  
oro chiaro opaco  
matt light gold

Il telaio in metallo è disponibile nei seguenti abbinamenti di finiture:

- bordo esterno e struttura interna brunito corten
- bordo esterno e struttura interna black aubergine
- bordo esterno e struttura interna oro chiaro opaco
- bordo esterno brunito corten e struttura interna oro chiaro opaco
- bordo esterno nuvolato corten e struttura interna black aubergine

Decorato con cristalli Asfour trasparenti.

Metal frame is available in the following combinations of finishes:

- external edge and internal structure burnished corten
- external edge and internal structure black aubergine
- external edge and internal structure matt light gold
- external edge burnished corten and internal structure matt light gold
- external edge cloudy corten and internal structure black aubergine

Decorated with transparent Asfour crystals.

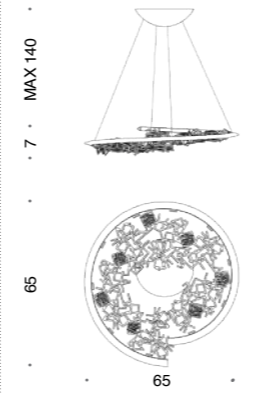
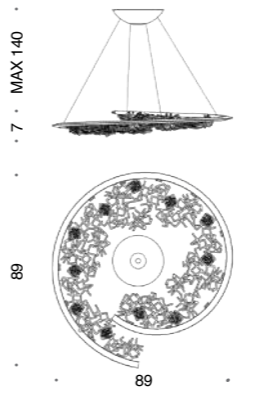
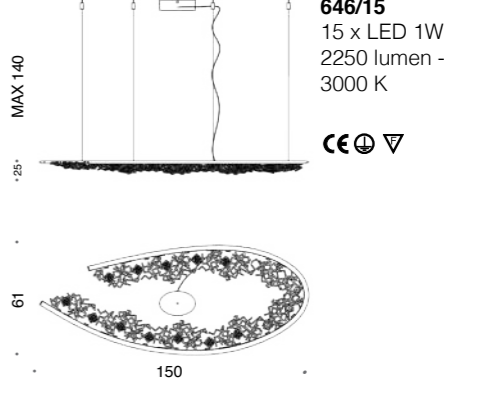
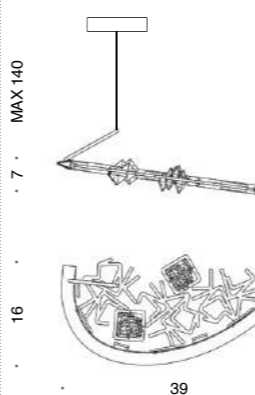
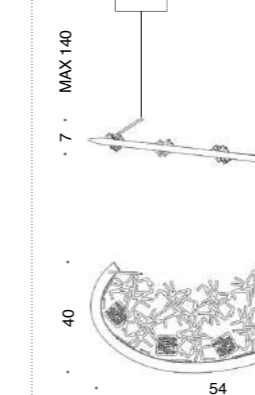
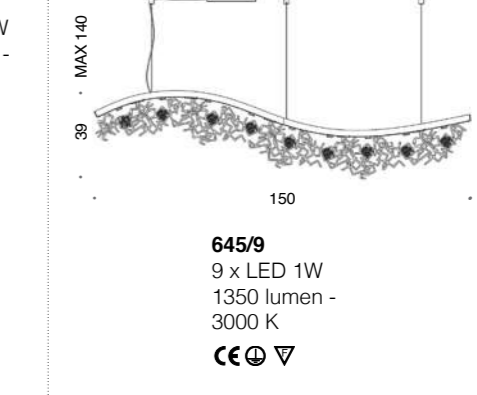

## SOSPENSIONE SUSPENSION

 <p><b>644/10</b> 10 x LED 1W 1500 lumen - 3000 K</p> <p>MAX 140 7 65</p> <p>CE ⊕ ▽</p>	 <p><b>644/14</b> 14 x LED 1W 2100 lumen - 3000 K</p> <p>MAX 140 7 89</p> <p>CE ⊕ ▽</p>	 <p><b>646/15</b> 15 x LED 1W 2250 lumen - 3000 K</p> <p>MAX 140 25 61 150</p> <p>CE ⊕ ▽</p>
 <p><b>647/4</b> 4 x LED 1W 600 lumen - 3000 K</p> <p>MAX 140 7 16 39</p> <p>CE ⊕ ▽</p>	 <p><b>647/5</b> 5 x LED 1W 750 lumen - 3000 K</p> <p>MAX 140 7 40 54</p> <p>CE ⊕ ▽</p>	 <p><b>645/9</b> 9 x LED 1W 1350 lumen - 3000 K</p> <p>MAX 140 38 150</p> <p>CE ⊕ ▽</p>

## PLAFONIERA CEILING LAMP

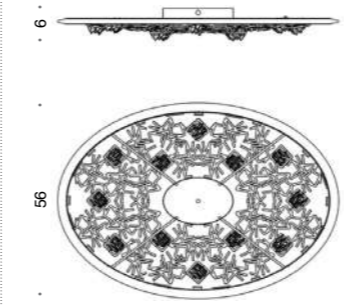

**646/12PF**  
12 x LED 1W  
1800 lumen -  
3000 K

6  
56  
80

CE ⊕ ▽

## APPLIQUE WALL BRACKET

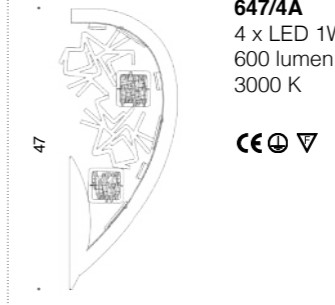

**647/4A**  
4 x LED 1W  
600 lumen -  
3000 K

47  
16

CE ⊕ ▽

## LAMPADA DA TAVOLO TABLE LAMP



**647/4L**  
4 x LED 1W  
600 lumen -  
3000 K

40  
16

CE ⊕ ▽

La finitura CORTEN (brunito) è un procedimento di ossidazione naturale. La realizzazione di tale processo è influenzata dal livello di umidità, dalla temperatura esterna e da altre variabili ambientali. La mano dell'uomo e la specifica lavorazione sono il valore aggiunto che testimonia l'autentico 'Made in Italy'. Come tutte le opere dove il procedimento non è meccanico ma artigianale le eventuali variazioni di colore non sono da considerarsi un difetto ma una testimonianza dell'unicità del prodotto. La finitura Corten rende quindi il prodotto unico e irripetibile. Le foto presenti nel nostro catalogo costituiscono solo un'identificazione del tipo di prodotto e non rappresentano un campione degli stessi.

The finish CORTEN (burnished) is the result of a procedure of natural oxidation. The procedure is every time affected by the percentage of humidity in the air, by the external temperature and by other environmental variables. Hands of man and a special processing are a value added, which is evidence of the real 'Made in Italy'. As in all works where the procedure is not mechanical but handcrafted, variations are possible, but they must not be considered as a defect, but rather as a proof of the uniqueness of the product. Corten finish makes the product as unique, since every results is not reproducible in identical way. The pictures of our catalogues are only an example of the kind of the product, but they cannot be considered strictly as samples of them, since the result can be different.



# Cesare

DESIGN *Cristian Feltrin*

Modello depositato. Registered design.



632/110 + 632/76 + 632/50 *sospensione suspension*





# Cesare

DESIGN Cristian Feltrin



oro spazzolato  
brushed gold

bronzo spazzolato  
brushed bronze

nichel spazzolato  
brushed nickel

nichel nero  
spazzolato  
brushed black  
nickel



vetro senza incisione  
glass without engraving



vetro con incisione  
glass with engraving



bronzo  
bronze

trasparente  
transparent

fumè  
smoke grey

satinato bianco e  
trasparente  
satin white and  
transparent

Telaio in metallo disponibile nelle finiture:

- nichel spazzolato
- nichel nero spazzolato
- oro spazzolato
- bronzo spazzolato

Vetro di Murano con incisione disponibile nelle finiture:

- cristallo
- fumè
- bronzo

Metal frame available in the finishes:

- brushed nickel
- brushed black nickel
- brushed gold
- brushed bronze

Murano glass with engraving available in the finishes:

- crystal
- fumè
- bronze

## SOSPENSIONE SUSPENSION

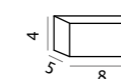
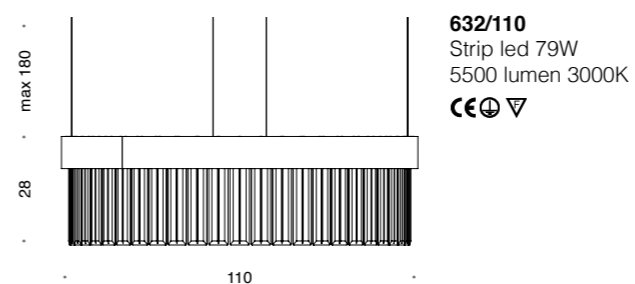
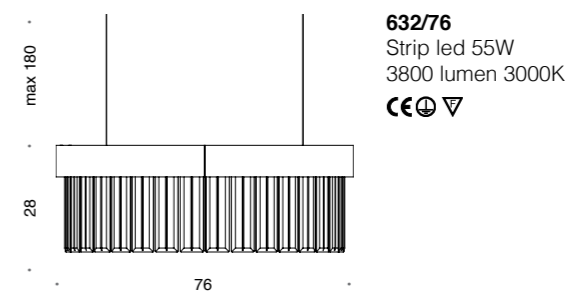
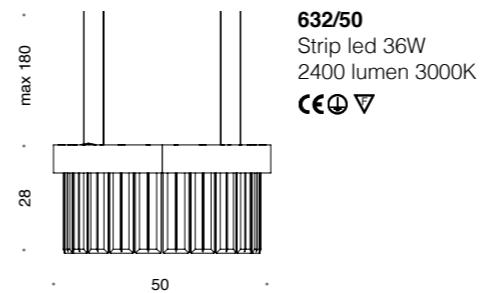

**KIT DIMMER LED**  
art.638/DIM24V

Kit dimmer disponibile per tutte le serie.

Kit dimmer available for all collections.



# Roma

DESIGN *Antonio Piva*

359/14 *sospensione suspension*

Modello depositato. Registered design.





359/22 *sospensione suspension*



359/5R *sospensione suspension*



359/90X90 *sospensione suspension*



359/4S *sospensione suspension*



359/5S *sospensione suspension*



359/4P *lampada da terra floor lamp*





359/5SP *sospensione suspension*





359/2A applique wall bracket

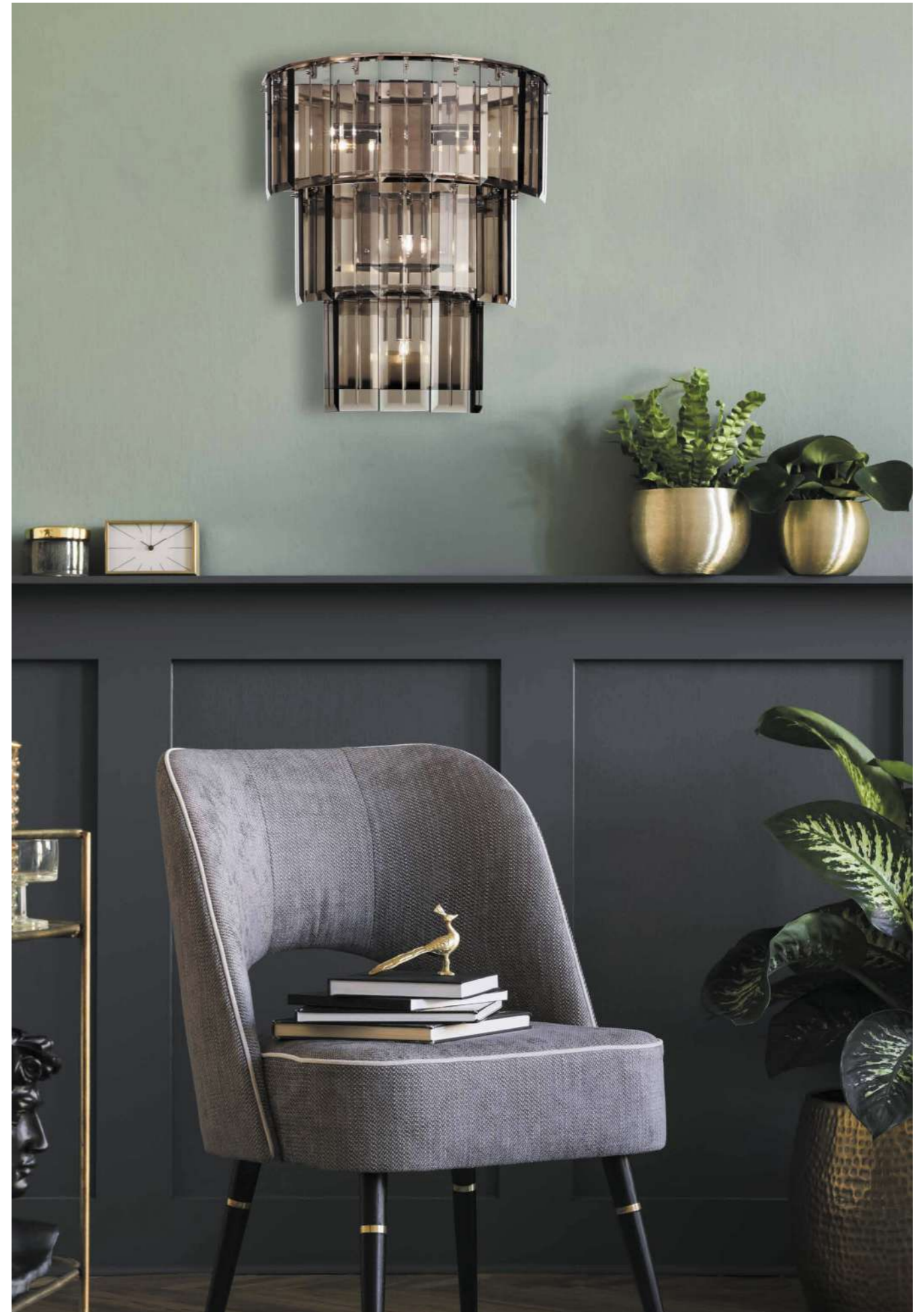

359/4A applique wall bracket



# ROMA

DESIGN Antonio Piva



vetro senza incisione  
glass without engraving



vetro con incisione  
glass with engraving

Telaio in metallo disponibile nelle seguenti finiture:

- oro chiaro
- nichel nero
- cromo
- black aubergine

I vetri diffusori, con o senza incisione centrale, sono disponibili nei seguenti colori:

- bronzo
- trasparente
- fumé
- satinato bianco.

Metal frame available in the following finishes:

- light gold
- black nickel
- chrome
- black aubergine

Diffuser glasses, with or without engraving, are available in the following colours:

- bronze
- transparent
- smoke grey
- satin white.

## SOSPENSIONE SUSPENSION

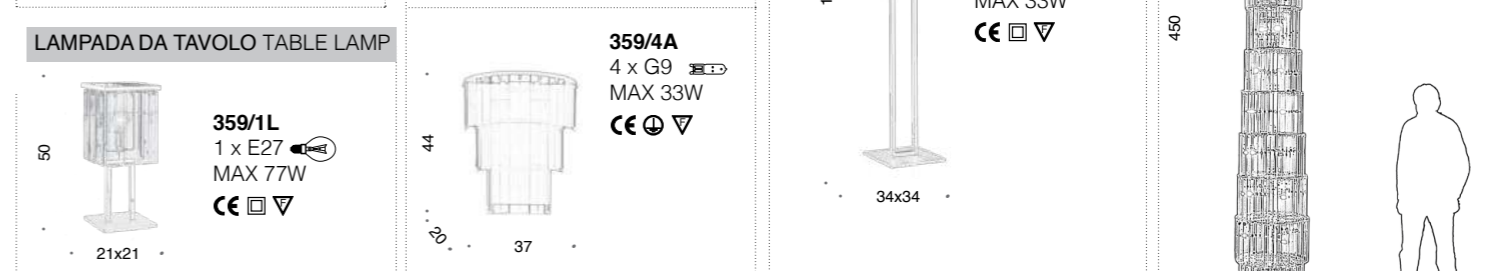
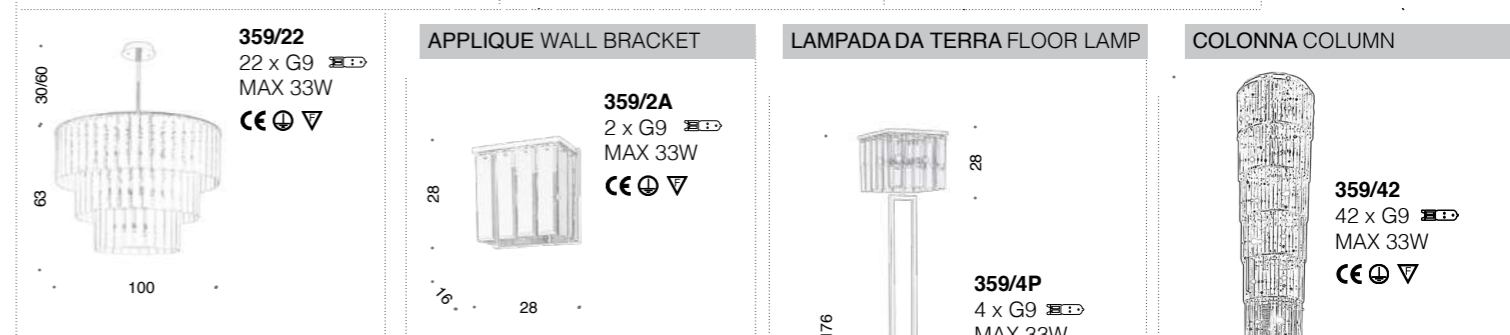
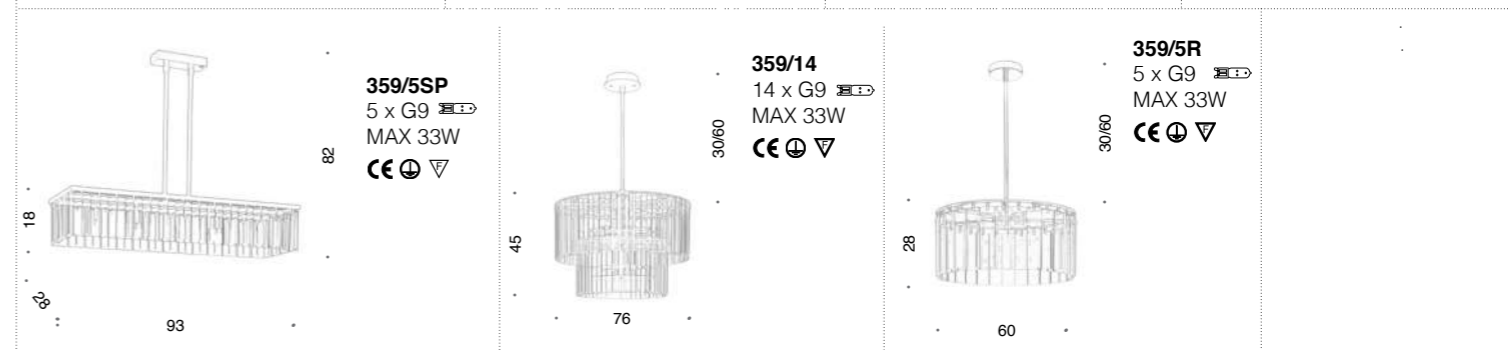
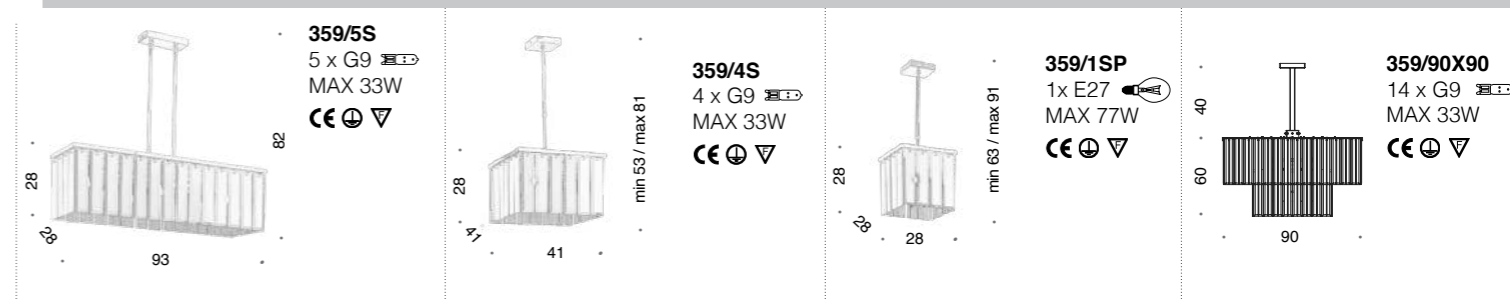

\* disponibili realizzazioni su misura  
custom made sizes available



# Crystalline

DESIGN *Cristian Feltrin*

Modello depositato. Registered design.



493/6 *sospensione suspension*

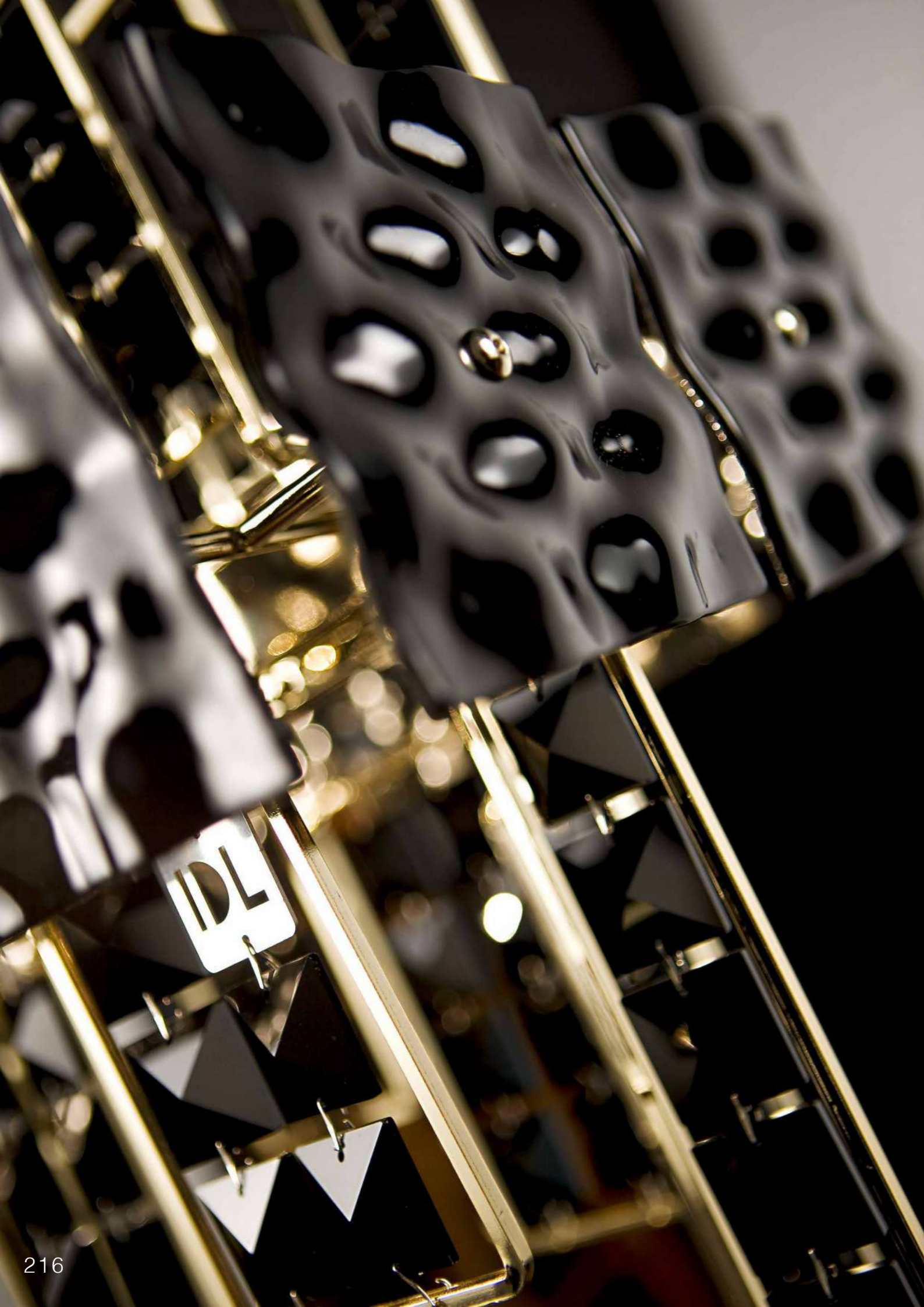



493/16+16 sospensione suspension

disponibili realizzazioni su misura custom made size available



493/10 sospensione suspension



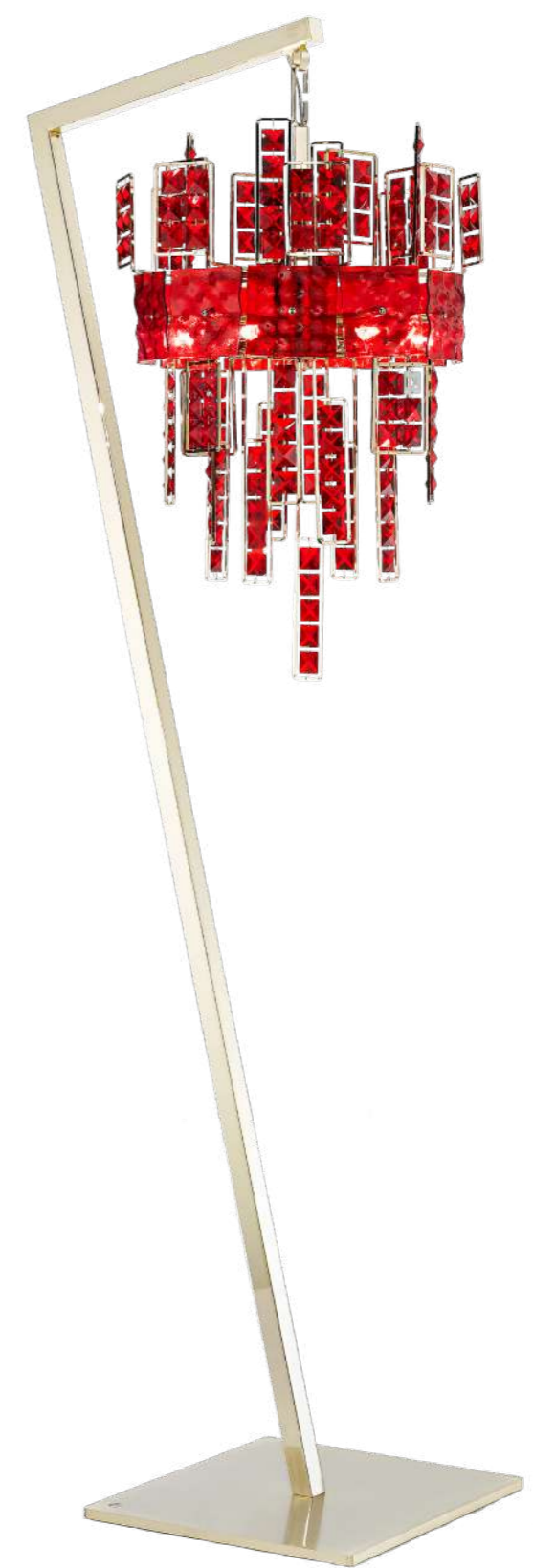

493/6P lampada da terra floor lamp



# CRYSTALLINE

DESIGN Cristian Feltrin

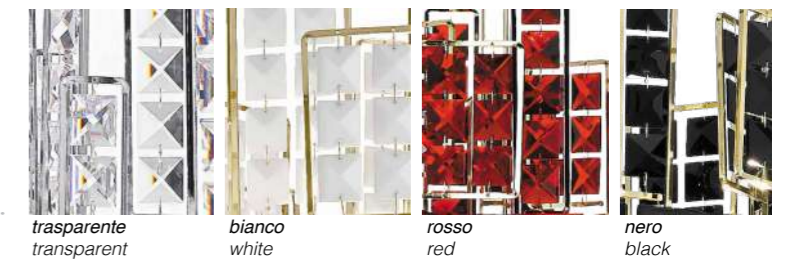

trasparente  
transparent

bianco  
white

rosso  
red

nero  
black



cromo  
chrome

oro chiaro  
light gold

Telaio in metallo cromato o oro chiaro  
Elementi in cristallo molato disponibili nelle seguenti varianti colore:

- cristallo trasparente
- cristallo bianco
- cristallo rosso
- cristallo nero

Nella lampada da tavolo e applique il diffusore è in policarbonato satinato.

Chromed or light gold metal frame.

Cut crystal elements available in the following colours:

- transparent crystal
- white crystal
- red crystal
- black crystal

On table lamp and wall lamp diffuser in satin polycarbonate.



## SOSPENSIONE SUSPENSION

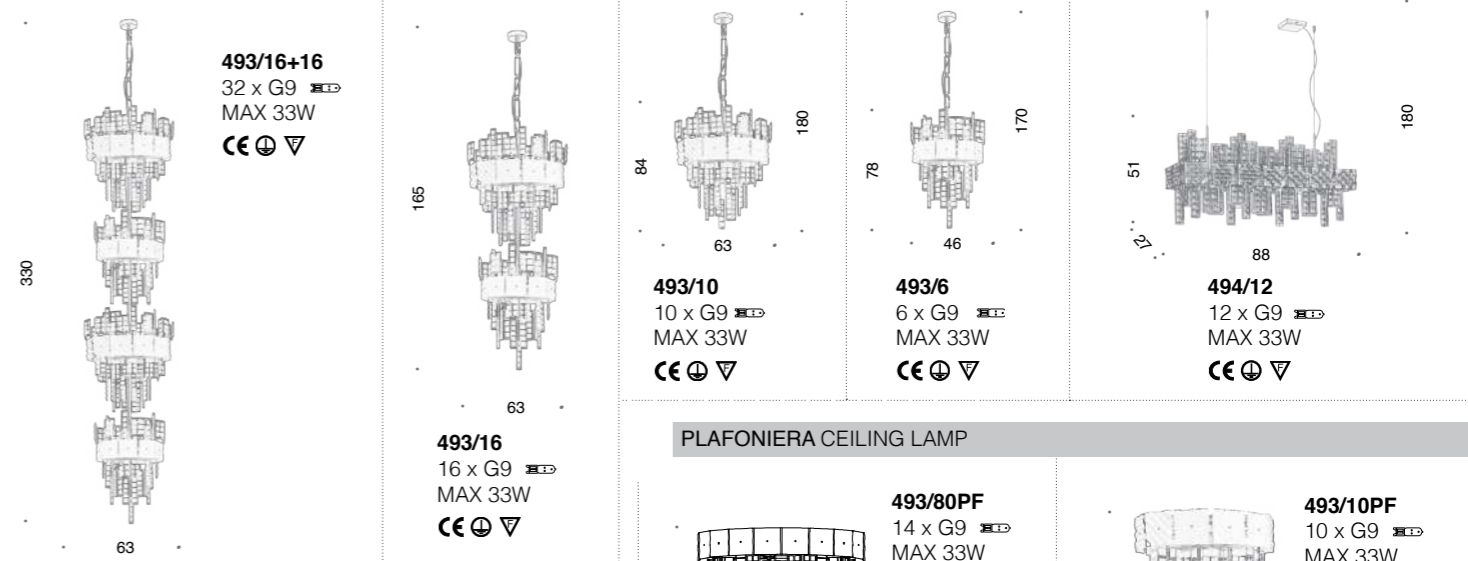

## PLAFONIERA CEILING LAMP

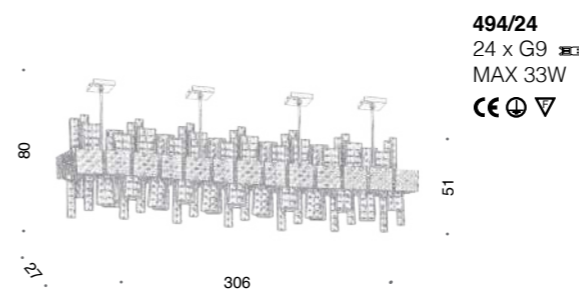
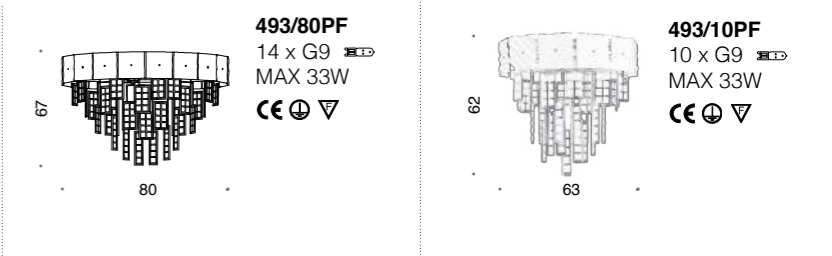

## APPLIQUE WALL BRACKET



## LAMPADA DA TAVOLO TABLE LAMP

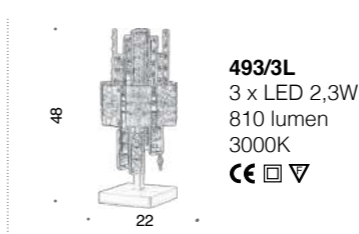

## LAMPADA DA TERRA FLOOR LAMP

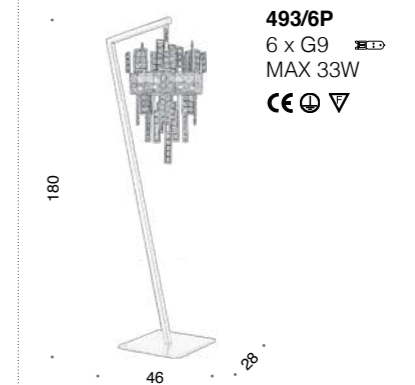



# Diamante

628/90 *sospensione suspension*

DESIGN *Cristian Feltrin*

226

Modello depositato. Registered design.

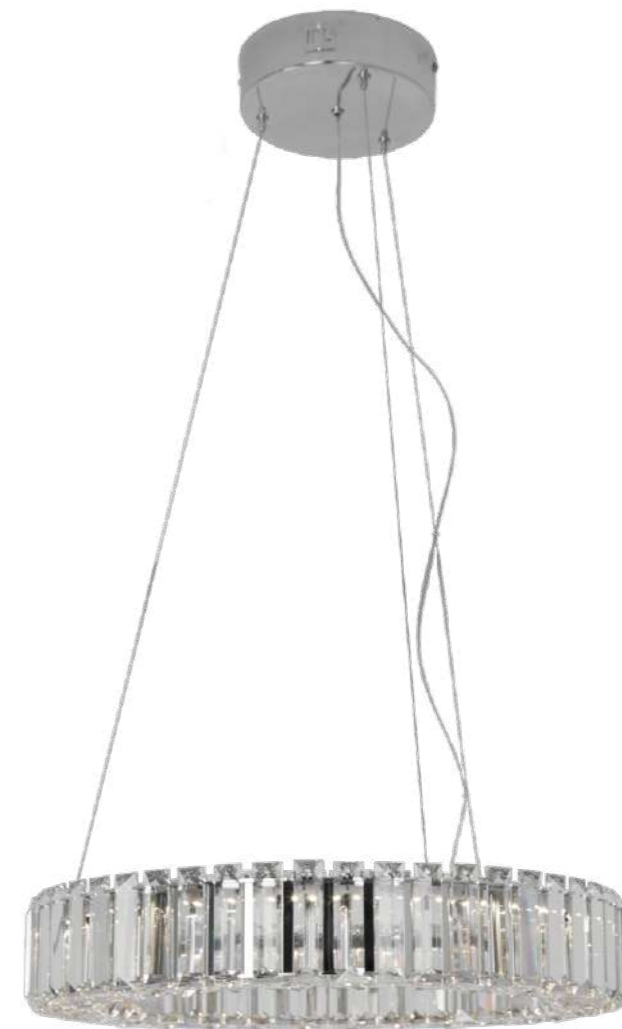

628/50 *sospensione suspension*

227





# DIAMANTE

DESIGN Cristian Feltrin

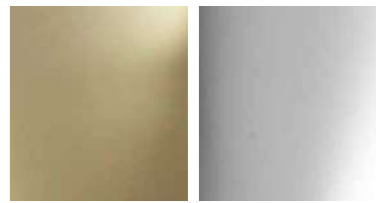

oro chiaro  
light gold

cromo  
chrome

Telaio in metallo disponibile nelle finiture:  
- cromo  
- oro chiaro

Metal frame available in the finishes:  
- chrome  
- light gold

Cristalli Asfour trasparenti.

Transparent Asfour crystals.

## SOSPENSIONE SUSPENSION

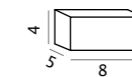
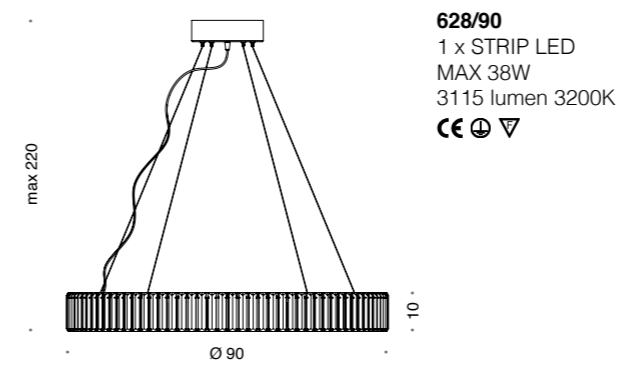
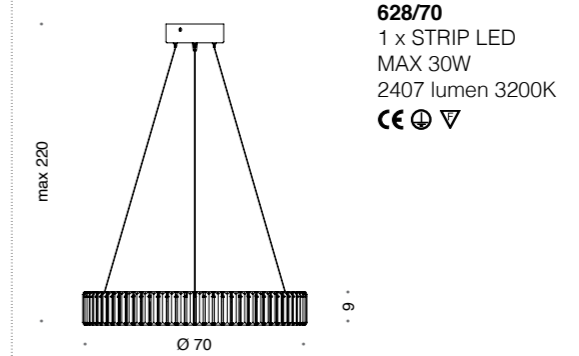
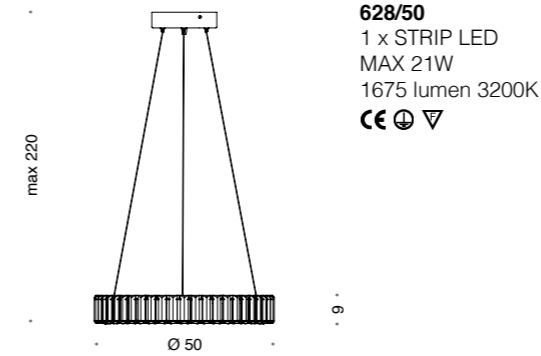

**KIT DIMMER LED**  
art.638/DIM24V

Kit dimmer disponibile per tutte le serie.

*Kit dimmer available for all collections.*



# Floritude

DESIGN *Cristian Feltrin*

664/9 sospensione suspension

Modello depositato. Registered design.

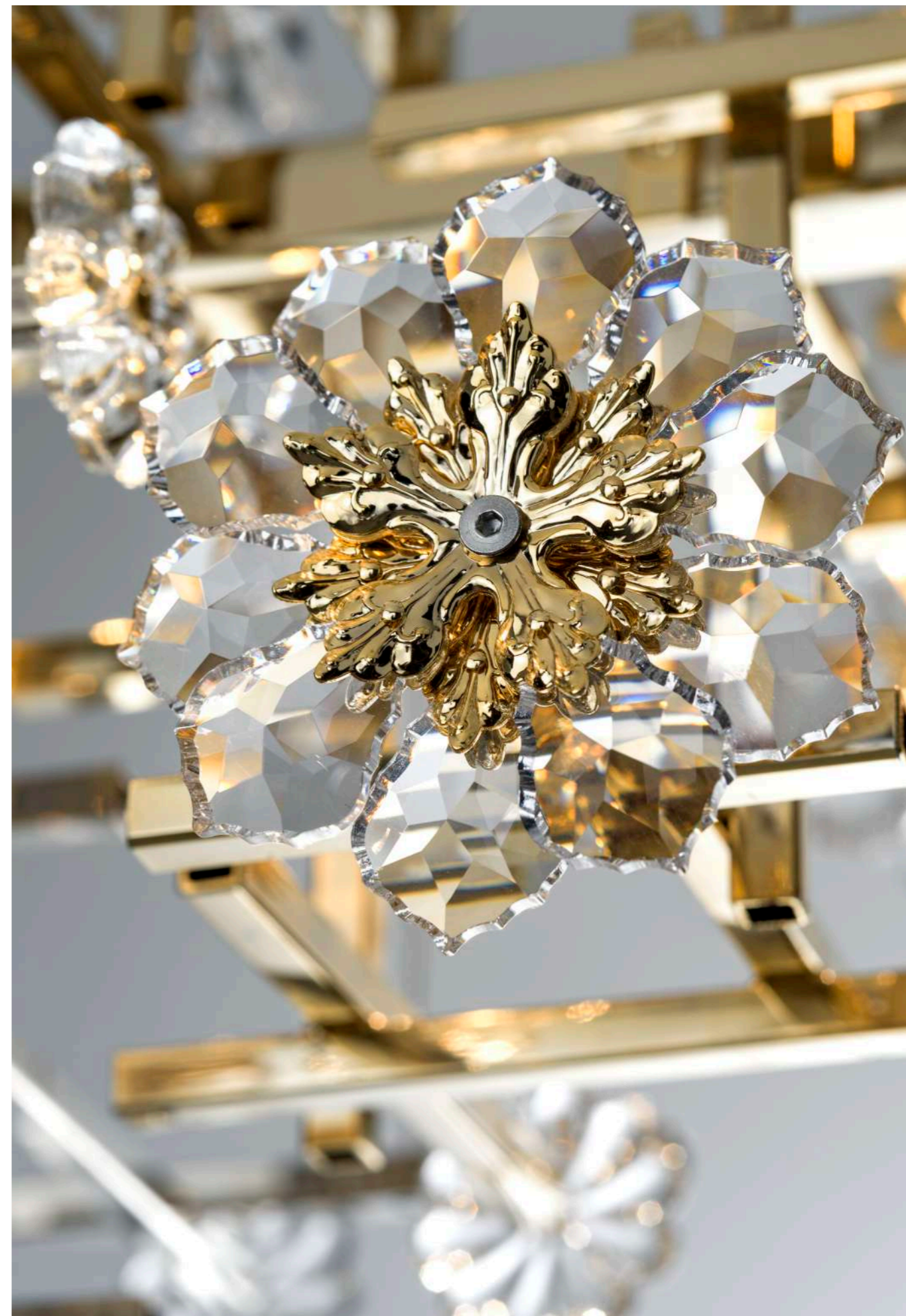



664/9 *sospensione suspension*

# FLORITUDE

DESIGN Cristian Feltrin

pure steel  
pure steel

oro chiaro  
light gold

Il telaio in metallo è disponibile nelle seguenti finiture:  
- oro chiaro  
- pure steel

Fiori in cristallo Asfour.

La collezione è decorata con cristalli trasparenti.

Metal frame is available in the following finishes:  
- light gold  
- pure steel

Flowers in Asfour crystals.

The collection is decorated with transparent crystals.

## SOSPENSIONE SUSPENSION

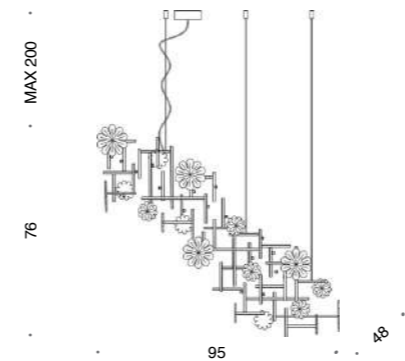

**664/9**  
9 x LED 3,6W  
3465 lumen - 3000 K

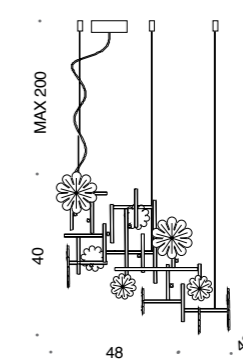
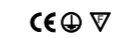

**664/5**  
5 x LED 3,6W  
1925 lumen - 3000 K





# Crystal Blade

DESIGN *Cristian Feltrin*

512/6+3 *sospensione suspension*

Modello depositato. Registered design.

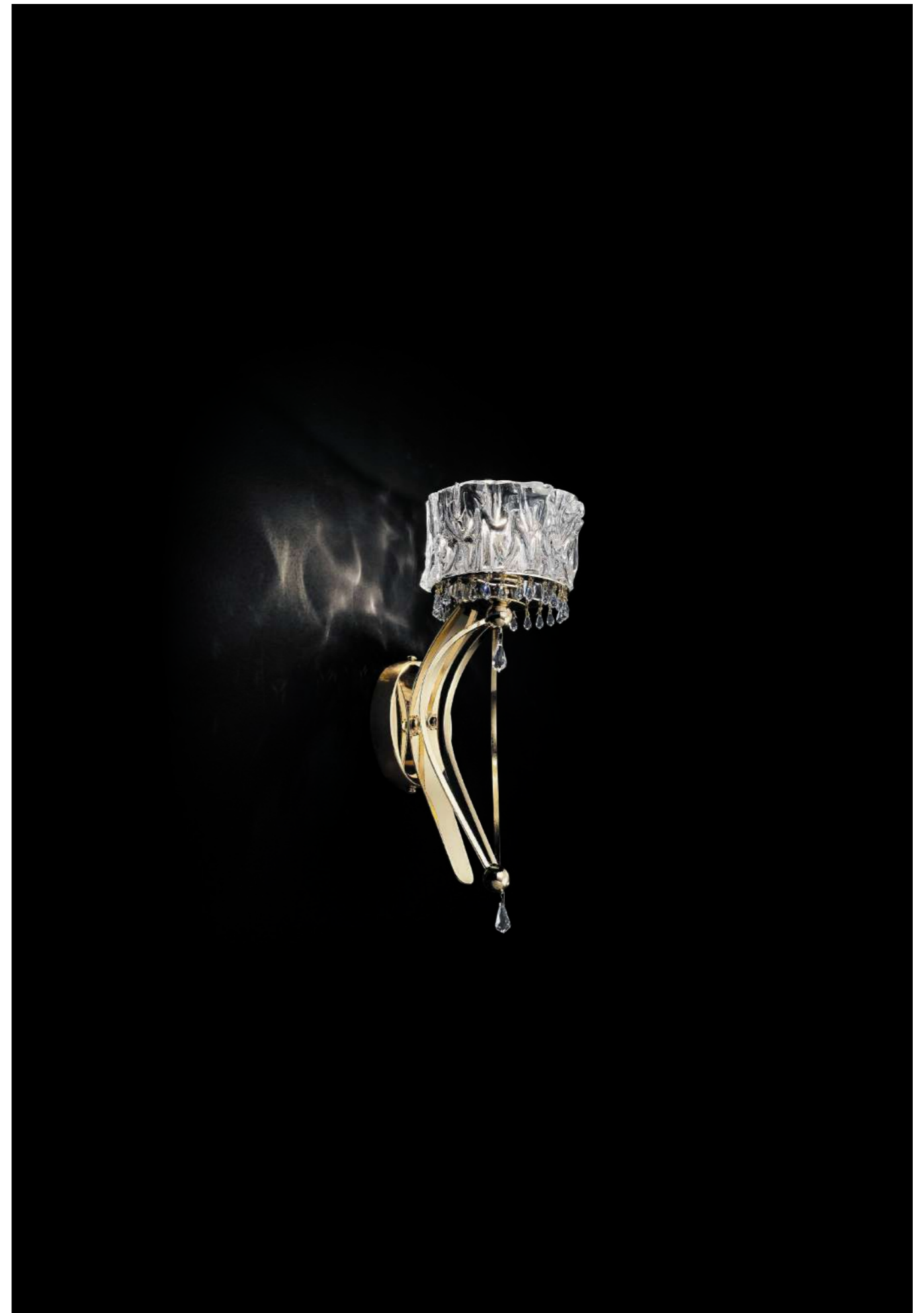

512/1A *applique wall bracket*





512/120 *sospensione suspension*



512/8 *sospensione suspension*



512/6 *sospensione suspension*





512/2A applique wall bracket



512/5SG sospensione suspension



512/5P lampada da terra floor lamp

# Crystal blade

DESIGN Cristian Feltrin



*chromo*  
chrome

*oro chiaro*  
light gold

*black aubergine*  
black aubergine

Telaio in metallo, disponibile nelle seguenti finiture:

- cromo
- oro chiaro
- black aubergine

Diffusori in vetro di Murano trasparenti.

Metal frame, available in the following finishes:

- chrome
- light gold
- black aubergine

Diffusers in transparent Murano glass.

La collezione è decorata con cristalli trasparenti.

The collection is decorated with transparent crystals.

## SOSPENSIONE SUSPENSION

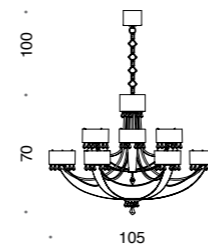

**512/6+3**  
9 x G9  
MAX 33W  
CE ⊕ ▽

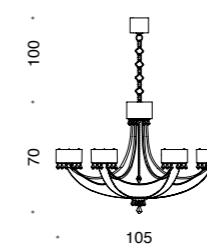

**512/8**  
8 x G9  
MAX 33W  
CE ⊕ ▽

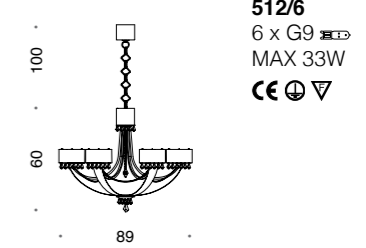

**512/6**  
6 x G9  
MAX 33W  
CE ⊕ ▽

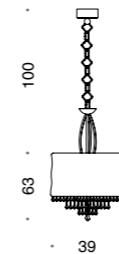

**512/5SG**  
5 x G9  
MAX 33W  
CE ⊕ ▽

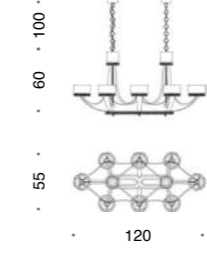

**512/120**  
8 x G9  
MAX 33W  
CE ⊕ ▽

## APPLIQUE WALL BRACKET

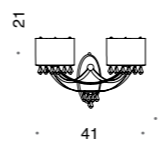

**512/2A**  
2 x G9  
MAX 33W  
CE ⊕ ▽

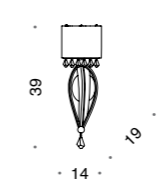

**512/1A**  
1 x G9  
MAX 33W  
CE ⊕ ▽

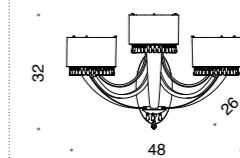

**512/3A**  
3 x G9  
MAX 33W  
CE ⊕ ▽

## LAMPADA DA TAVOLO TABLE LAMP

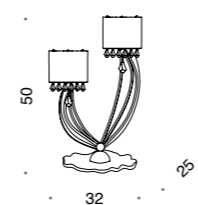

**512/2L**  
2 x G9  
MAX 33W  
CE ⊕ ▽

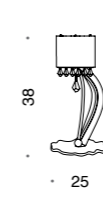

**512/1L**  
1 x G9  
MAX 33W  
CE ⊕ ▽

## LAMPADA DA TERRA FLOOR LAMP

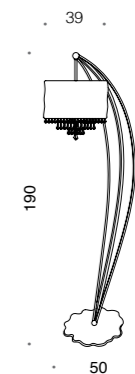

**512/5P**  
5 x G9  
MAX 33W  
CE ⊕ ▽



512/2L lampada da tavolo table lamp



512/1L lampada da tavolo table lamp



# Paradise

430/62 sospensione suspension

DESIGN Cristian Feltrin

Modello depositato. Registered design.





430/62 *sospensione suspension*



430/2ASX *applique wall bracket*





430/62 *sospensione suspension*



430/100 *sospensione suspension*



430/4A applique wall bracket



430/2ADX applique wall bracket



430/20 sospensione suspension



430/42PF plafoniera ceiling lamp



430/1L lampada da tavolo table lamp



430/90PF plafoniera ceiling lamp

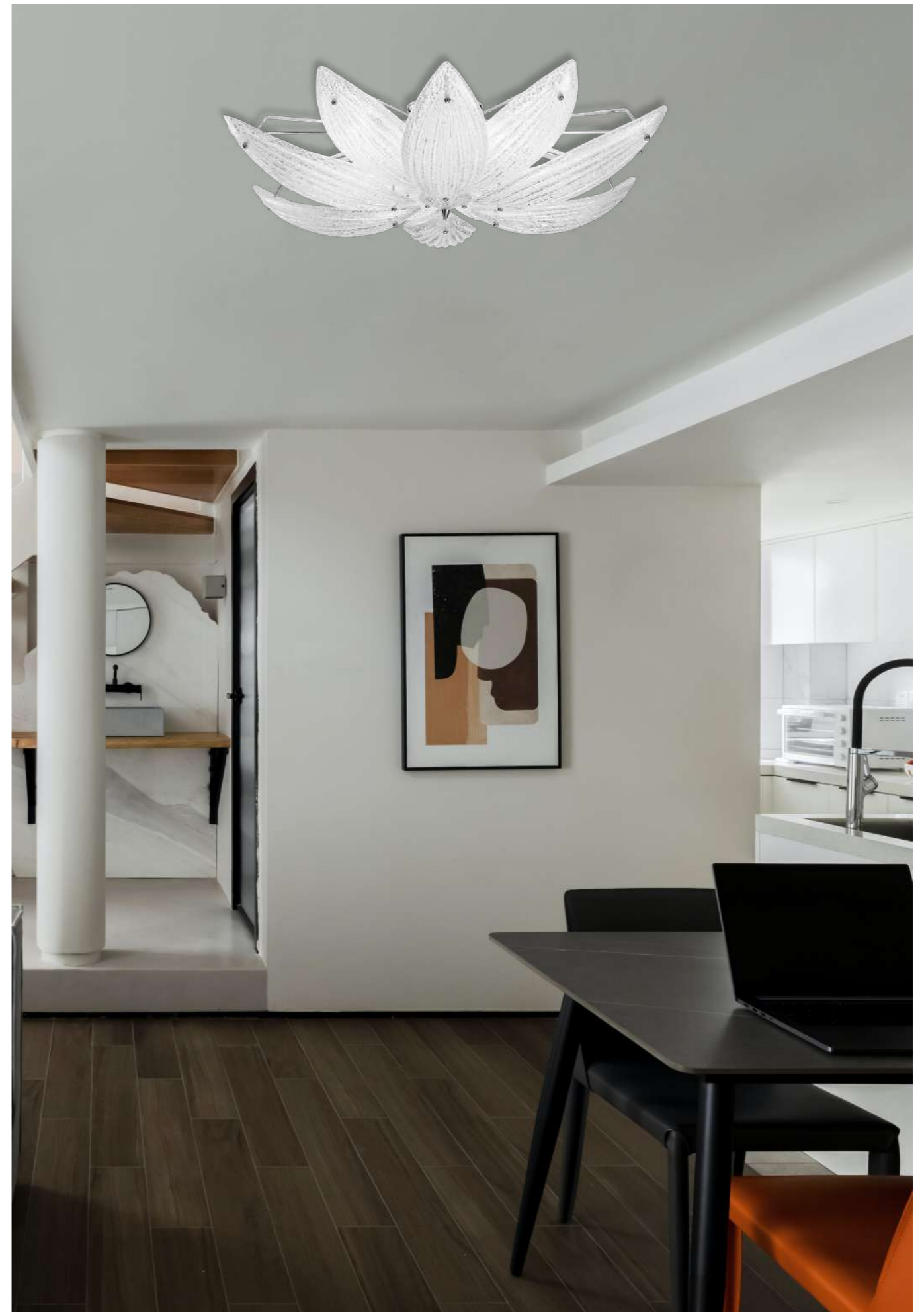

430/90PF plafoniera ceiling lamp



430/1P lampada da terra floor lamp

# Paradise

DESIGN Cristian Feltrin

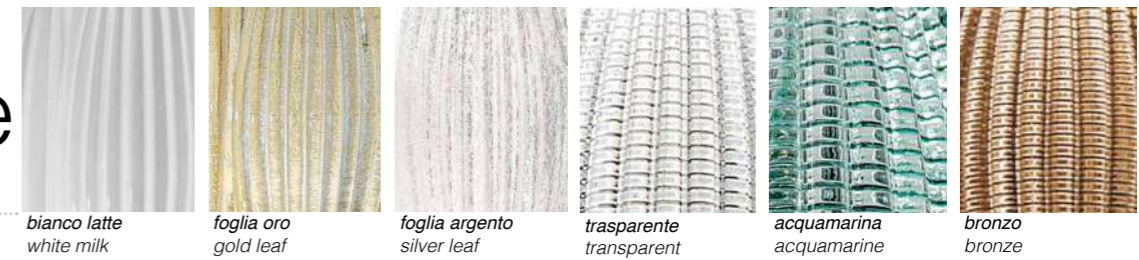

Telaio in metallo, disponibile con finitura cromo o oro chiaro. Le basi della lampada da terra e della lampada da tavolo sono in finitura nichel spazzolato. Vetri in Murano disponibili nei seguenti colori:

- bianco latte
- foglia oro
- foglia argento
- trasparente
- bronzo
- acquamarina

Metal frame available in chrome or light gold finish. The bases of the floor lamp and table lamp are in brushed nickel frame finish. Murano glass available in the following finishes:

- white
- gold leaf
- silver leaf
- transparent
- bronze
- aquamarine

## SOSPENSIONE SUSPENSION

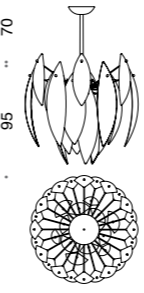
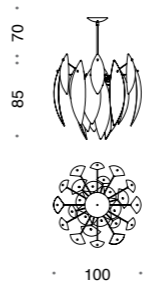
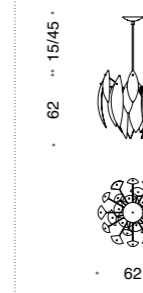
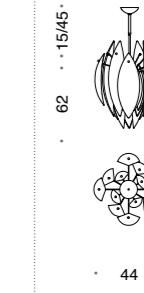
 <p><b>430/120</b> 18 x G9 MAX 33W CE ⊕ ▽</p> <p>120</p>	 <p><b>430/100</b> 18 x G9 MAX 33W CE ⊕ ▽</p> <p>100</p>	 <p><b>430/62</b> 10 x G9 MAX 33W CE ⊕ ▽</p> <p>62</p>	 <p><b>430/42</b> 1 x E27 MAX 77W CE ⊕ ▽</p> <p>44</p>
---	---	---	---

## PLAFONIERA CEILING LAMP

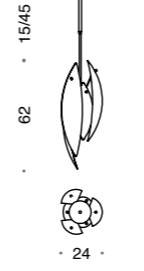
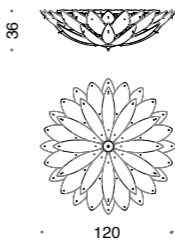
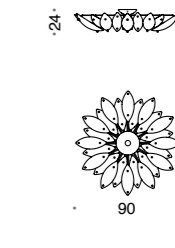
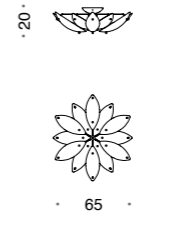
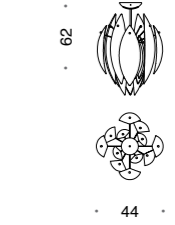
 <p><b>430/20</b> 1 x E27 MAX 77W CE ⊕ ▽</p> <p>24</p>	 <p><b>430/120PF</b> 16 x G9 MAX 33W CE ⊕ ▽</p> <p>120</p>	 <p><b>430/90PF</b> 12 x G9 MAX 33W CE ⊕ ▽</p> <p>90</p>
 <p><b>430/65PF</b> 6 x G9 MAX 33W CE ⊕ ▽</p> <p>65</p>	 <p><b>430/42PF</b> 1 x E27 MAX 77W CE ⊕ ▽</p> <p>44</p>	

## APPLIQUE WALL BRACKET

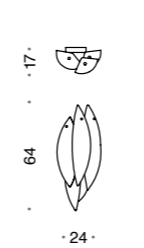
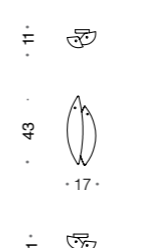
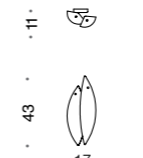
 <p><b>430/4A</b> 4 x G9 MAX 33W CE ⊕ ▽</p> <p>24</p>	 <p><b>430/2ASX</b> 2 x G9 MAX 33W CE ⊕ ▽</p> <p>17</p>	 <p><b>430/2ADX</b> 2 x G9 MAX 33W CE ⊕ ▽</p> <p>17</p>
--	--	--

## LAMPADA DA TAVOLO TABLE LAMP

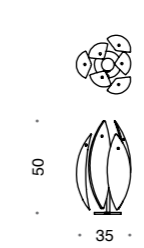
 <p><b>430/1L</b> 1 x E27 MAX 77W CE ⊕ ▽</p> <p>35</p>
---

## LAMPADA DA TERRA FLOOR LAMP

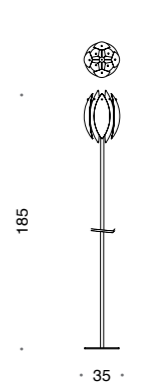
 <p><b>430/1P</b> 1 x E27 MAX 77W CE ⊕ ▽</p> <p>185</p>
--



# Angel

DESIGN IDL Staff

653/6+6 sospensione suspension

Modello depositato. Registered design.



653/1AP applique wall bracket



653/1SP *sospensione suspension*

653/1SG *sospensione suspension*



# ANGEL

DESIGN IDL Staff



pure steel  
pure steel

oro chiaro  
light gold

nichel spazzolato  
brushed nickel

oro spazzolato  
opaco  
matt brushed gold

Il telaio in metallo è disponibile nelle seguenti finiture:

- oro spazzolato opaco
- nichel spazzolato
- oro chiaro
- pure steel

Metal frame is available in the following finishes:

- matt brushed gold
- brushed nickel
- light gold
- pure steel

Vetro di Murano trasparente pulegoso.

Pulegoso transparent Murano glass.





## SOSPENSIONE SUSPENSION

 <p>150 26 145</p>	<p><b>653/6+6</b> 12 x STRIP LED MAX 96W 2754 lumen - 3000 K CE ⊕ ▽</p>	 <p>MAX 140 38 65 45</p>	<p><b>653/2+1S</b> 3 x STRIP LED MAX 26W 486 lumen - 3000 K CE ⊕ ▽</p>
 <p>MAX 140 63 28</p>	<p><b>653/1SG</b> 1 x STRIP LED MAX 10W 207 lumen - 3000 K CE ⊕ ▽</p>	 <p>MAX 140 38 17</p>	<p><b>653/1SP</b> 1 x STRIP LED MAX 6W 153 lumen - 3000 K CE ⊕ ▽</p>

## APPLIQUE WALL BRACKET

 <p>38 24</p>	<p><b>653/1AP</b> 1 x LED MAX 7W 153 lumen - 3000 K CE ⊕ ▽</p>
--	--

## LAMPADA DA TAVOLO TABLE LAMP

 <p>42 26</p>	<p><b>653/1LP</b> 1 x LED MAX 5W 153 lumen - 3000 K CE ⊕ ▽</p>	 <p>88 32</p>	<p><b>653/1LG</b> 1 x LED MAX 9W 207 lumen - 3000 K CE ⊕ ▽</p>
--	--	--	--





# Crystal Moon

DESIGN *Cristian Feltrin*

Modello depositato. Registered design.



475/12 *sospensione suspension*



475/12PF plafoniera ceiling lamp



475/1AG-PFG applique wall bracket

475/1AP-PFP applique wall bracket



475/1SP *sospensione suspension*



475/1SG *sospensione suspension*



475/8 *sospensione suspension*

# Crystal moon

DESIGN Cristian Feltrin



oro chiaro  
light gold

Telaio in metallo oro chiaro.  
Diffusori in vetro di Murano bianco lavorato con fascia in graniglia e con effetto battuto.  
La collezione è decorata con cristalli.

Light gold metal frame.  
White Murano glass diffusers worked with grit band and wrought effect.  
The collection is decorated with crystals.



## SOSPENSIONE SUSPENSION

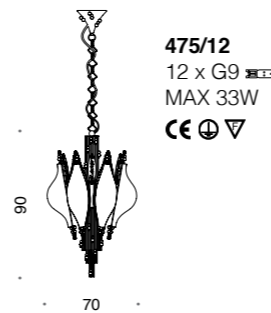

**475/12**  
12 x G9  
MAX 33W  
CE ⊕ ▽

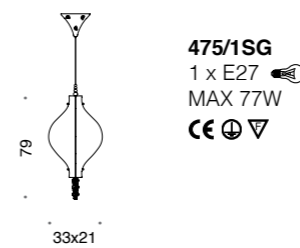

**475/1SG**  
1 x E27  
MAX 77W  
CE ⊕ ▽

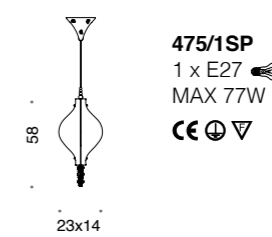

**475/1SP**  
1 x E27  
MAX 77W  
CE ⊕ ▽

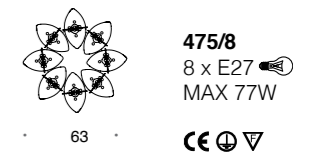

**475/8**  
8 x E27  
MAX 77W  
CE ⊕ ▽

## PLAFONIERA CEILING LAMP

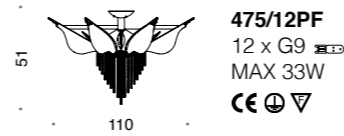

**475/12PF**  
12 x G9  
MAX 33W  
CE ⊕ ▽

## APPLIQUE/PLAFONIERA WALL BRACKET/CEILING LAMP

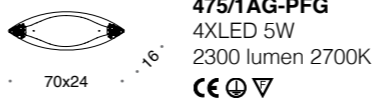

**475/1AG-PFG**  
4xLED 5W  
2300 lumen 2700K  
CE ⊕ ▽

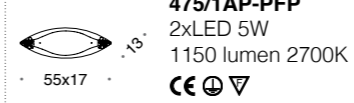

**475/1AP-PFP**  
2xLED 5W  
1150 lumen 2700K  
CE ⊕ ▽

## LAMPADA DA TAVOLO TABLE LAMP

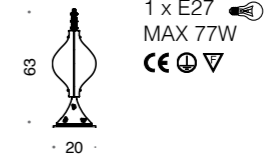

**475/1L**  
1 x E27  
MAX 77W  
CE ⊕ ▽



585/1L lampada da tavolo *table lamp*



# Vanity

DESIGN Cristian Feltrin

Modello depositato. Registered design.

# Vanity

DESIGN Cristian Feltrin



Telaio in metallo disponibile in:

Metal frame available in:

Per la collezione 585 le sfere sono in metallo e vetro, mentre nella serie 484 sono tutte in metallo.

For the collection 585 the spheres are in metal and transparent glass, instead for the collection 484 the spheres are all in metal.



*nichel nero*  
black nickel



*pure steel*  
pure steel



*bronzo*  
bronze



*rame*  
coppery



*oro chiaro*  
light gold

Paralume disponibile in:

Lampshade available in:



*plissé avorio*  
ivory plissé



*plissé bianco*  
white plissé



*chinette avorio*  
ivory chinette



*chinette tortora*  
dove grey chinette

## LAMPADA DA TAVOLO TABLE LAMP



**585/1L**  
1 x E27  
MAX 77W  
CE Ⓢ Ⓣ



**584/1L**  
1 x E27  
MAX 77W  
CE Ⓢ Ⓣ



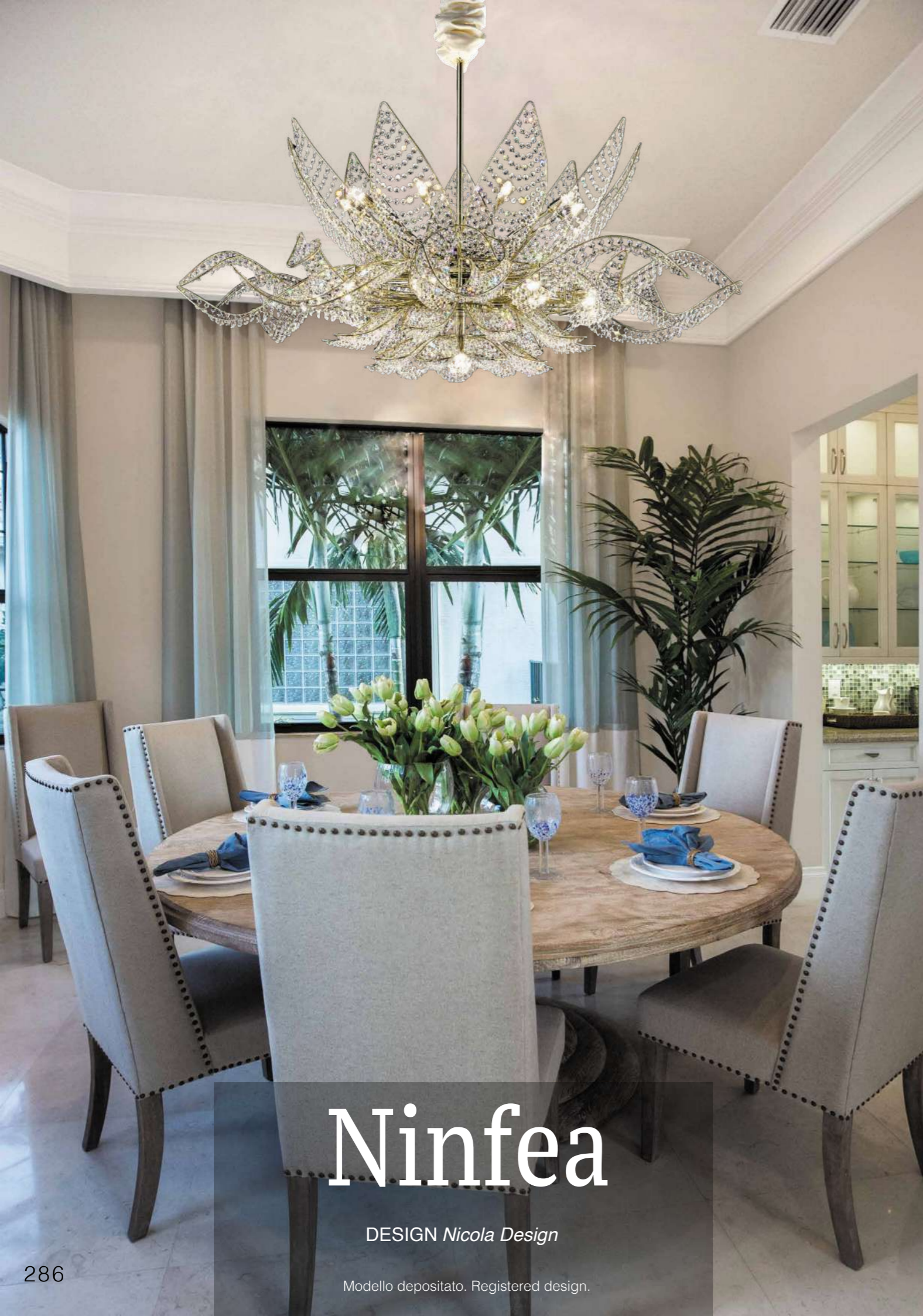

# Ninfea

DESIGN *Nicola Design*

Modello depositato. Registered design.



436/18+1 *sospensione suspension*





436/18+1 *sospensione suspension*



436/5P *lampada da terra floor lamp*

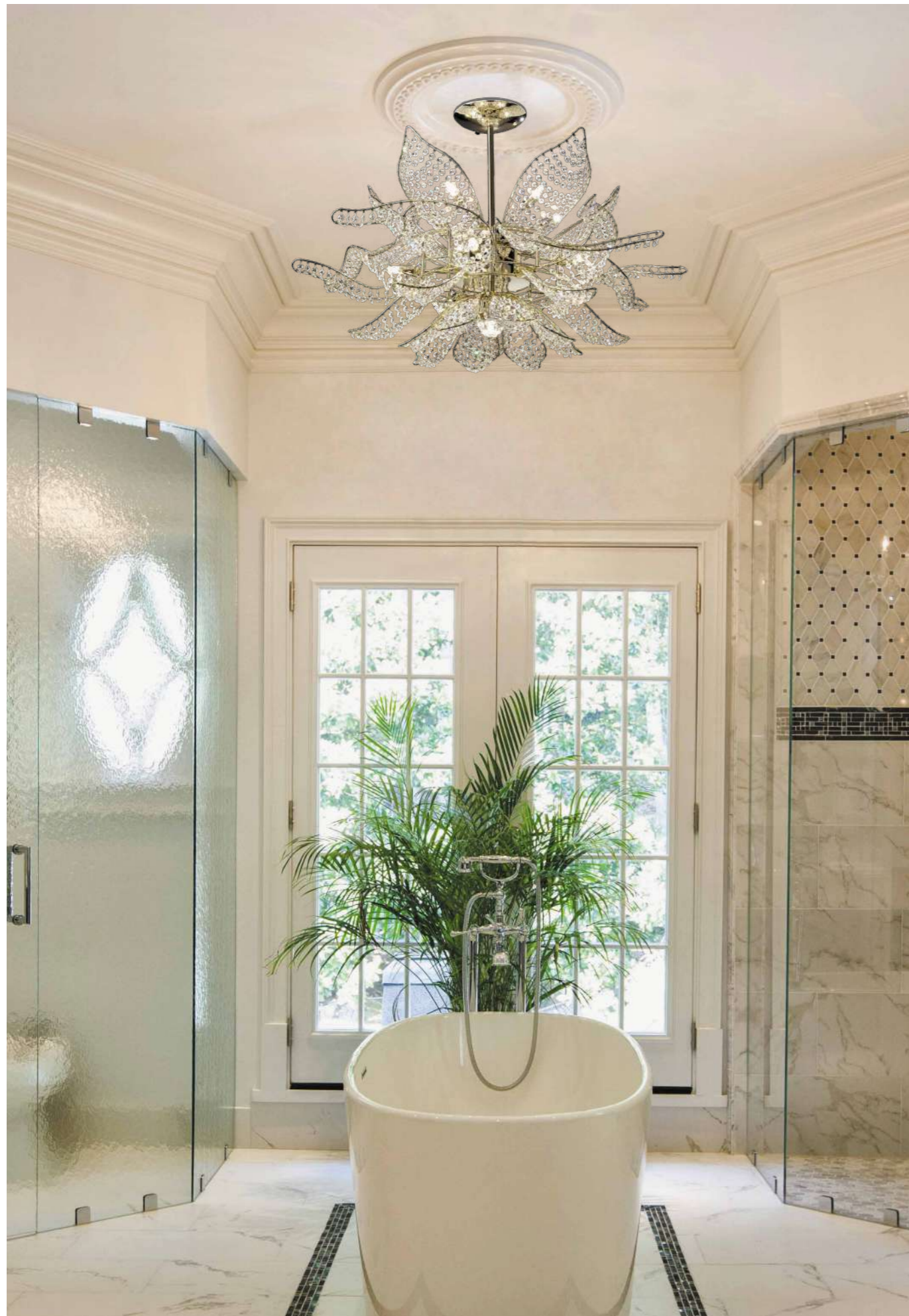

436/10+1PF plafoniera ceiling lamp



436/4+1A applique wall bracket

# Ninfea

DESIGN Nicola Design



*chrome e cristalli trasparenti*  
chrome and transparent crystals

*oro chiaro e cristalli trasparenti*  
light gold and transparent crystals

*chrome e perle vetro bianco*  
chrome and white glass pearls

*oro chiaro e perle vetro bianco*  
light gold and white glass pearls



Telaio in metallo, disponibile con finitura cromata o oro chiaro.  
Disponibile nella versione con perle in vetro di Murano bianco latte  
oppure con cristalli trasparenti.

Metal frame, available in chrome or light gold finish.  
Available with white Murano glass pearls or with transparent crystals.

## SOSPENSIONE SUSPENSION

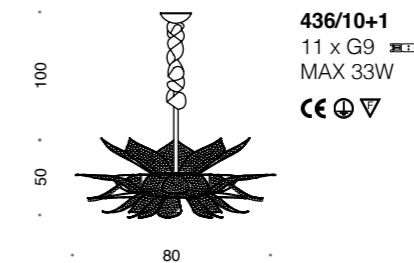
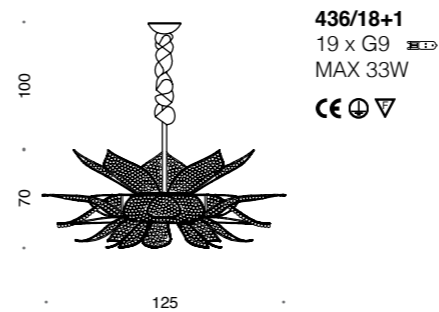

## APPLIQUE WALL BRACKET

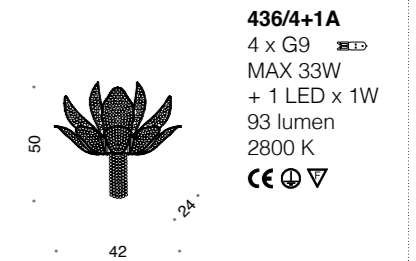

## PLAFONIERA CEILING LAMP

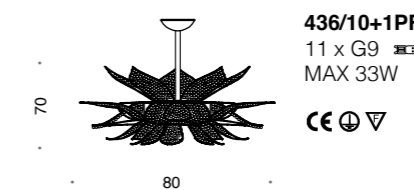
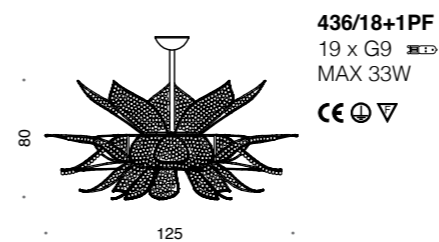

## LAMPADA DA TAVOLO TABLE LAMP

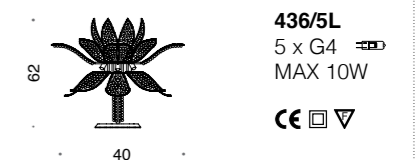

## LAMPADA DA TERRA FLOOR LAMP

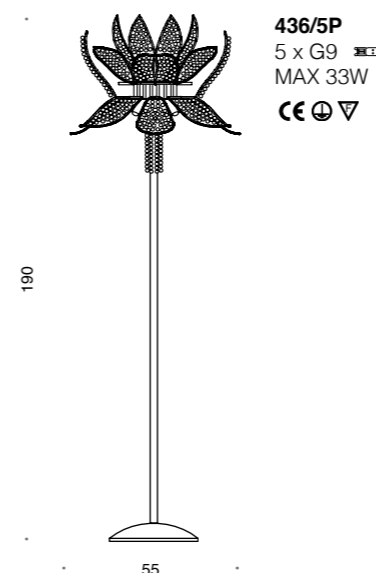



# Divina

DESIGN *Cristian Feltrin*

Modello depositato. Registered design.

439/12 *sospensione suspension*



439/6 *sospensione suspension*



439/9 sospensione suspension



439/6L lampada da tavolo table lamp





# Divina

DESIGN Cristian Feltrin



oro chiaro  
light gold

cromo  
chrome



Telaio in metallo, disponibile con finitura cromata o oro chiaro.

La versione cromata, prevede pendenti in cristallo trasparenti e viola, rose in vetro di Murano trasparenti e viola.

La versione oro chiaro, prevede pendenti in cristallo trasparenti e ambra, rose in vetro di Murano trasparenti e ambra.

Metal frame, available with chrome or light gold finish.

The chrome version provides crystal pendants in transparent and violet colour, Murano glass roses in transparent and violet colour.

The light gold version, provides crystals pendants in transparent and amber colour, Murano glass roses in transparent and amber colour.

La collezione è decorata con cristalli trasparenti.

The collection is decorated with transparent crystals.

## SOSPENSIONE SUSPENSION

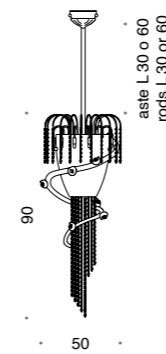

**439/12**  
doppia accensione  
double switch  
12xG4 LED  
MAX 3,5W  
+ 1xGU10 LED  
MAX 4,6W 2700K  
CE Ⓢ Ⓡ

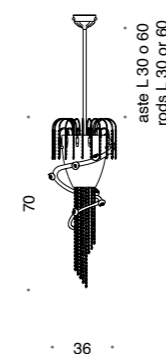

**439/9**  
doppia accensione  
double switch  
9xG4 LED  
MAX 3,5W  
+ 1xGU10 LED  
MAX 4,6W 2700K  
CE Ⓢ Ⓡ

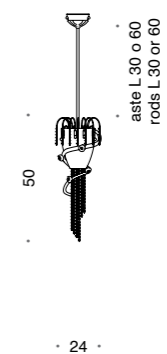

**439/6**  
doppia accensione  
double switch  
6xG4 LED  
MAX 3,5W  
+ 1 LED  
MAX 1W  
93 lumen 2700K  
CE Ⓢ Ⓡ

## APPLIQUE WALL BRACKET

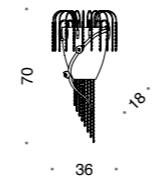

**439/6A**  
doppia accensione  
double switch  
6xG4 LED  
MAX 3,5W  
+ 1 LED  
MAX 1W  
93 lumen 2700K  
CE Ⓢ Ⓡ

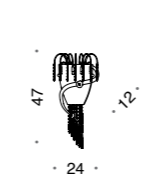

**439/3+2A**  
doppia accensione  
double switch  
3xG4 LED  
MAX 3,5W  
+ 2 LED  
MAX 1W  
186 lumen 2700 K  
CE Ⓢ Ⓡ

## LAMPADA DA TAVOLO TABLE LAMP

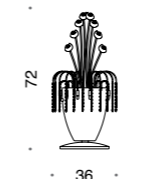

**439/6L**  
doppia accensione  
double switch  
6xG4 LED  
MAX 3,5W  
+ 1 LED  
MAX 1W  
93 lumen 2700K  
CE Ⓢ Ⓡ

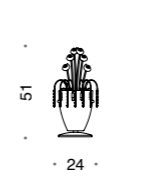

**439/3L**  
doppia accensione  
double switch  
3 x G4 LED  
MAX 3,5W  
+ 1 LED  
MAX 1W  
93 lumen 2700K  
CE Ⓢ Ⓡ

## PIANTANA FLOOR LAMP

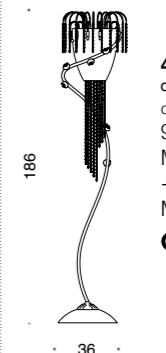

**439/9P**  
doppia accensione  
double switch  
9 x G4 LED  
MAX 3,5W  
+ 1 x GU10 LED  
MAX 4,6W 2700K  
CE Ⓢ Ⓡ





# Charme

DESIGN *Cristian Feltrin*

Modello depositato. Registered design.



600/1LG lampada da tavolo *table lamp*



600/1LP lampada da tavolo *table lamp*



600/1LM lampada da tavolo *table lamp*



601/1LM lampada da tavolo *table lamp*

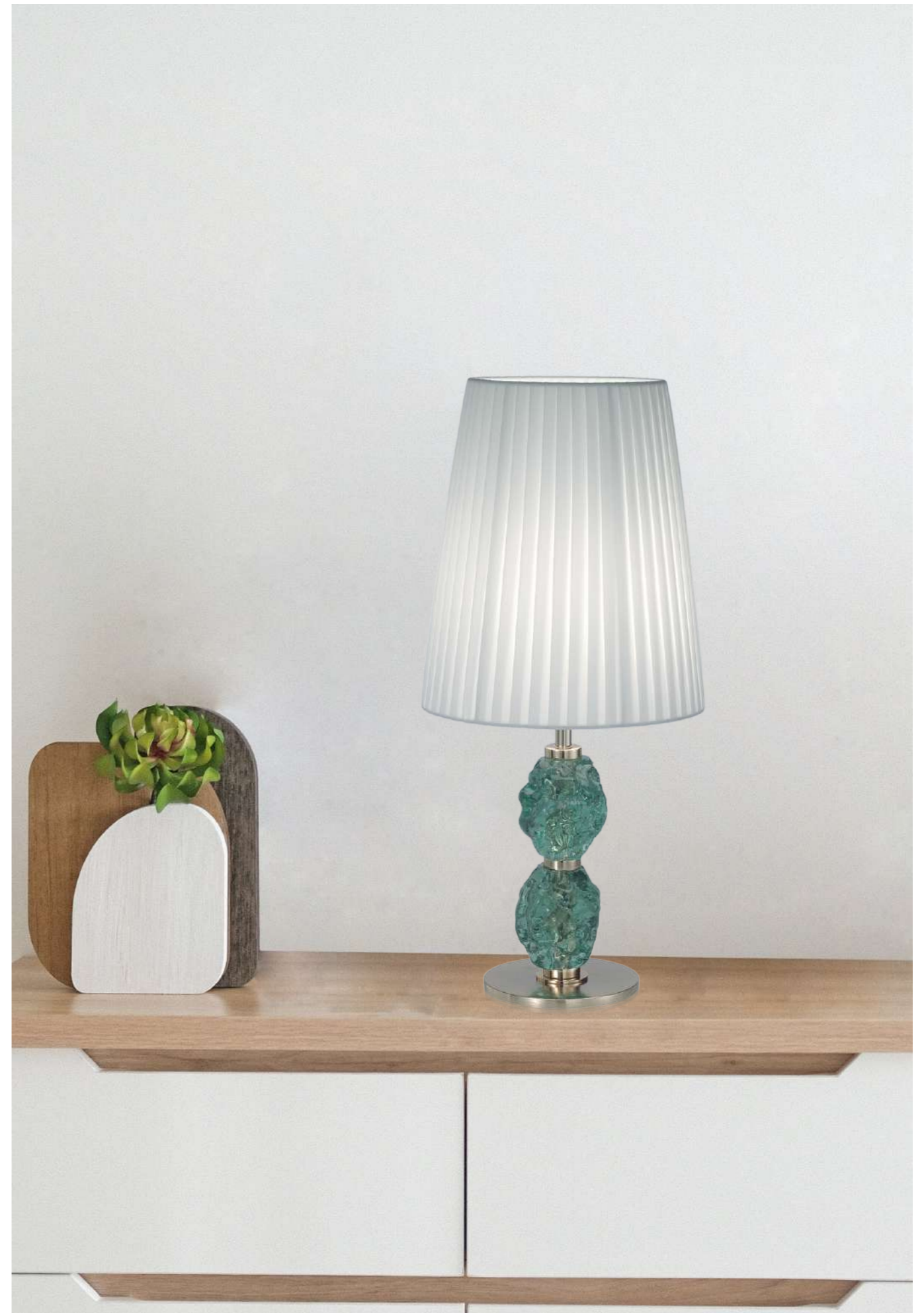



601/1LG lampada da tavolo *table lamp*



601/1LM lampada da tavolo *table lamp*



600/9P lampada da terra floor lamp



600/7P lampada da terra floor lamp



600/13P lampada da terra floor lamp



# Charme

DESIGN Cristian Feltrin

Telaio in metallo disponibile in:  
Metal frame available in:



Paralume disponibile in:  
Lampshade available in:



Vetro decorativo disponibile in:  
Decorative glass available in:



Telaio in metallo disponibile in finiture:

- pure steel
- nichel nero
- bronzo
- rame
- oro chiaro

Paralume disponibile in tessuto:

- chinette avorio o tortora
- juta chiaro o juta scuro
- plissé rosso, blu, verde, bianco, avorio

Vetro decorativo in Murano disponibile in colori:

cristallo, ambra, fumè, azzurro, verde, bianco o avorio.

Metal frame available in the following finishes:

- pure steel
- black nickel
- bronze
- coppery
- light gold

Lampshade available with fabric:

- ivory or dove grey chinette
- light or dark jute
- red, blue, green, white or ivory plissé

Red, amber, smoke grey, light blue, green, white or black decorative Murano glass.

## LAMPADA DA TAVOLO TABLE LAMP



**601/1LG**  
1 x E27  
MAX 77W  
CE □ ▽



**601/1LM**  
1 x E27  
MAX 77W  
CE □ ▽

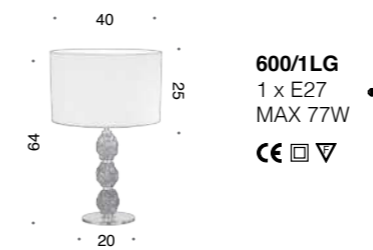

**600/1LG**  
1 x E27  
MAX 77W  
CE □ ▽

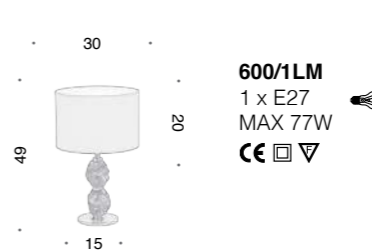

**600/1LM**  
1 x E27  
MAX 77W  
CE □ ▽



**600/1LP**  
1 x E14  
MAX 30W  
CE □ ▽

## LAMPADA DA TERRA FLOOR LAMP

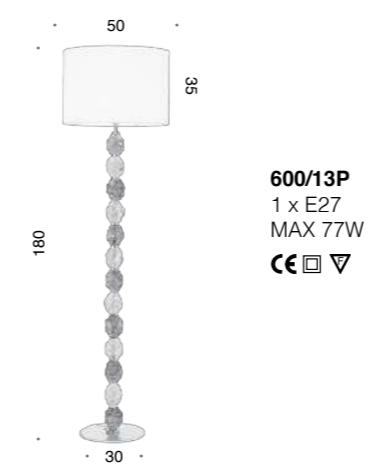

**600/13P**  
1 x E27  
MAX 77W  
CE □ ▽

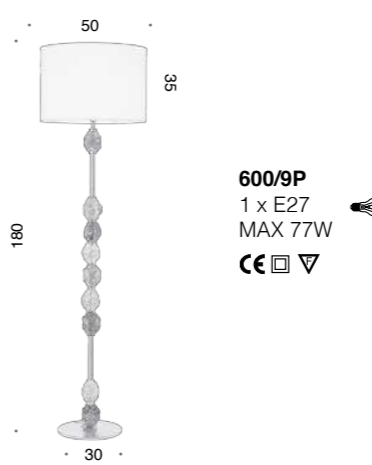

**600/9P**  
1 x E27  
MAX 77W  
CE □ ▽

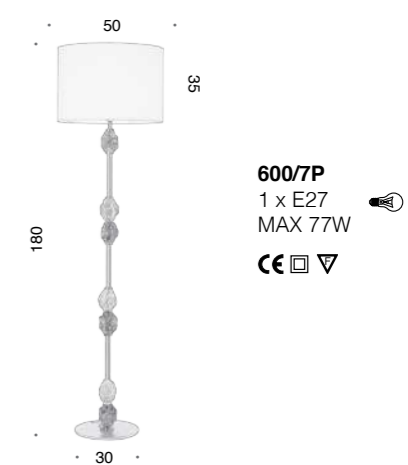

**600/7P**  
1 x E27  
MAX 77W  
CE □ ▽



# Grace

DESIGN IDL Staff

530/6 sospensione suspension

Modello depositato. Registered design.



530/6+3 sospensione suspension

# GRACE

DESIGN IDL Staff



oro spazzolato  
brushed gold



cromo spazzolato  
brushed chrome



nero velluto  
velvet black



nicel nero  
spazzolato  
brushed black nickel



bianco velluto  
white velvet



lamè argento  
silver lamè



lamè oro  
gold lamè

Telaio in metallo, disponibile nelle seguenti finiture:

- Bianco Velluto
- Nero Velluto
- Nickel Nero Spazzolato
- Cromo Spazzolato
- Oro Spazzolato

Paralumi in tessuto Lamè disponibili in Oro o Argento.

The metal frames available in the following finishes :

- Velvet White
- Velvet Black
- Brushed Black Nickel
- Brushed Chrome
- Brushed Gold

Fabric lampshades Lamè Gold or Silver



## SOSPENSIONE SUSPENSION

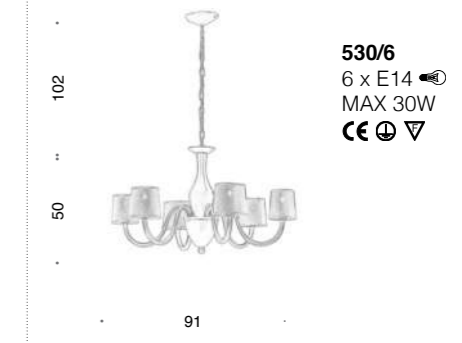
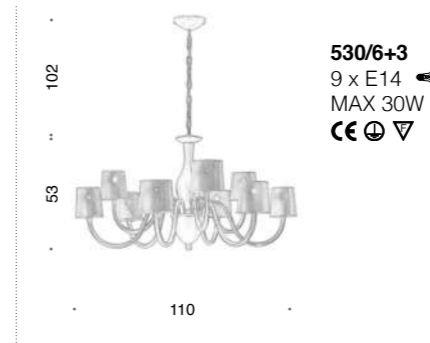
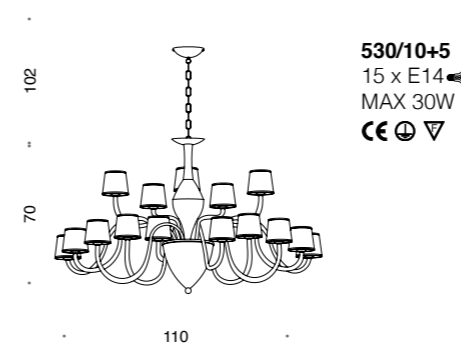

## APPLIQUE WALL BRACKET

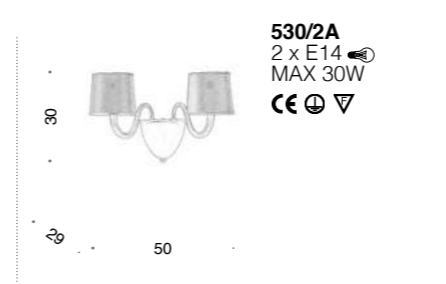





# Flame

DESIGN *Cristian Feltrin*

Modello depositato. Registered design.

525/6 sospensione suspension





524/10 *sospensione suspension*



524/1P *lampada da terra floor lamp*





**524/5PF** plafoniera ceiling lamp

**524/3PF** plafoniera ceiling lamp



524/2A applique wall bracket



524/1A applique wall bracket

# FLAME

DESIGN Cristian Feltrin



bianco velluto + oro chiaro  
velvet white + light gold

bianco velluto + nichel opaco  
velvet white + satin nickel

bronzo antico + nichel opaco  
antique bronze + matt nickel

bronzo antico + oro chiaro  
antique bronze + light gold

rame + pure steel  
copper + pure steel

organza bianco  
white organza

organza marrone  
brown organza

vetro Pyrex  
glass transparent  
Pyrex

Telaio in metallo, disponibile nelle seguenti finiture:

- Bianco Velluto e Oro Chiaro
- Bianco Velluto e Nichel Opaco
- Bronzo antico e Nichel Opaco o Bronzo antico e Oro Chiaro
- Rame e Pure Steel

Diffusori disponibili in due diverse varianti:

- Vetro Pyrex trasparente (codice 525)
- Paralumi in organza bianco o marrone (codice 524).

Pendenti in cristallo trasparente.

Metal frame, available in the following finishes:

- Velvet White and Light Gold
- Velvet White and Satin Nickel
- Antique bronze and Satin Nickel or Antique bronze and Light Gold
- Copper and Pure Steel

Diffusers available in two different combinations:

- Transparent Pyrex glass (code 525)
- White or brown organza Lampshades (code 524).

Transparent Crystal Pendants.

## SOSPENSIONE SUSPENSION

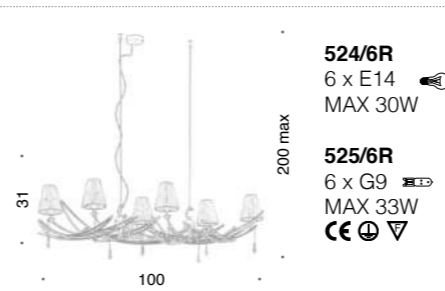
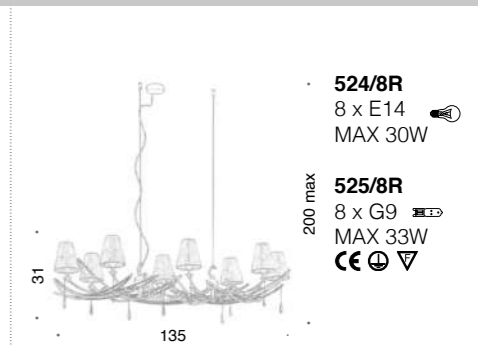
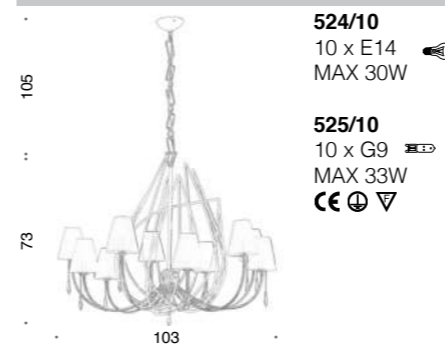

## PLAFONIERA CEILING LAMP

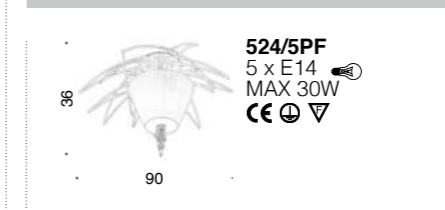

## APPLIQUE WALL BRACKET



## LAMPADA DA TAVOLO TABLE LAMP

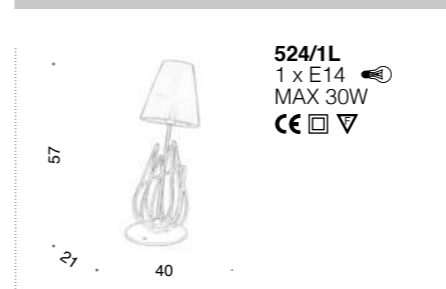

## LAMPADA DA TERRA FLOOR LAMP

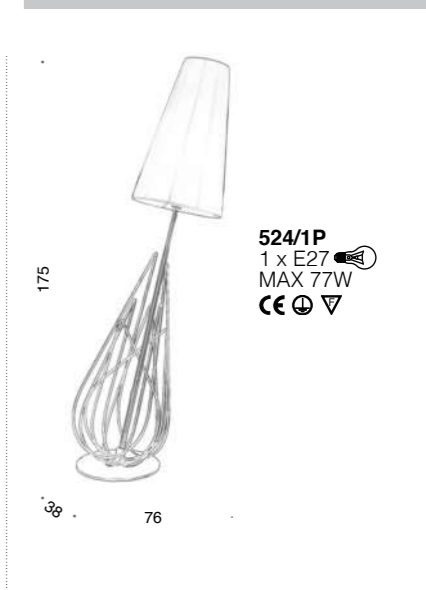

524/1L lampada da tavolo table lamp



# Prestige

DESIGN *Cristian Feltrin*

532/6 *sospensione suspension*

Modello depositato. Registered design.



534/1A *applique wall bracket*



532/6+6 *sospensione suspension*



532/1L *lampada da tavolo table lamp*





534/1S *sospensione suspension*

532/1S *sospensione suspension*



532/6+3 *sospensione suspension*



534/2A applique wall bracket



534/6 sospensione suspension

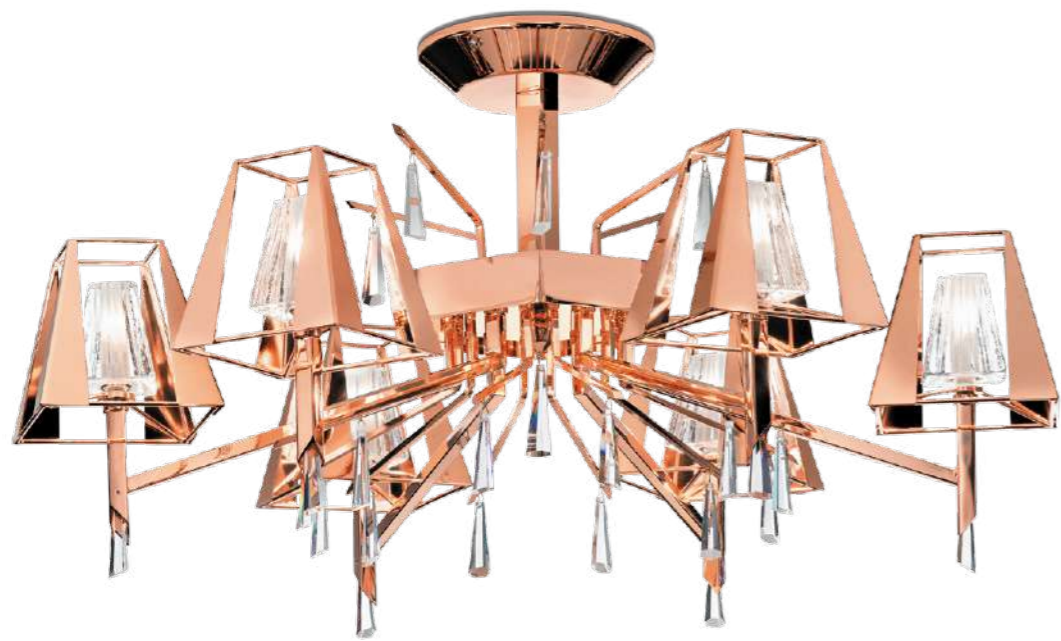

532/6PF plafoniera ceiling lamp



532/1A applique wall bracket



534/6 *sospensione suspension*



534/8R *sospensione suspension*



532/6P lampada da terra floor lamp

# PRESTIGE

DESIGN Cristian Feltrin



rame  
copper

pure steel  
pure steel

nicel nero  
black nichel

ruggine  
rusty

Telaio in metallo, disponibile nelle seguenti finiture:

- rame
- pure steel
- nichel nero
- ruggine

Diffusori disponibili in due diverse varianti:

- metallo e vetro Murano (codice 532)
- metallo e fasciatura in organza (codice 534)

Paralume in organza disponibile nei colori:

- rosé
- ghiaccio
- tortora
- oro

Metal frame, available in the following finishes:

- copper
- pure steel
- black nickel
- rusty

Diffuser available in two different combinations:

- metal and Murano glass (code 532)
- metal and organza (code 534)

Organza lampshade available in the following colours:

- rosé
- ice
- dove grey
- gold

## SOSPENSIONE SUSPENSION

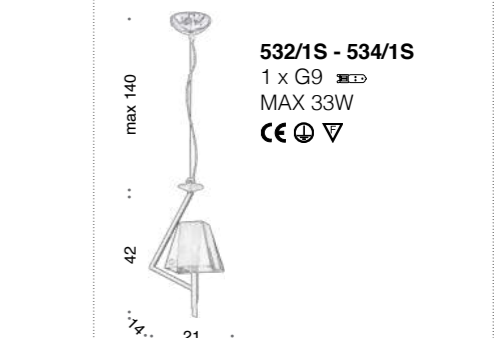
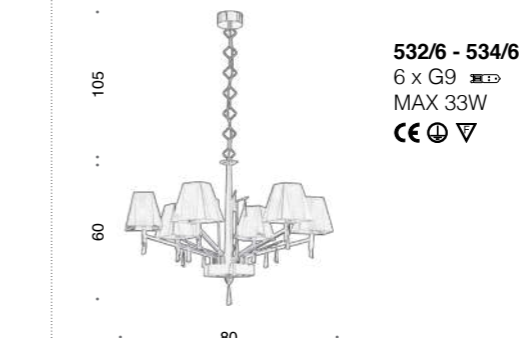
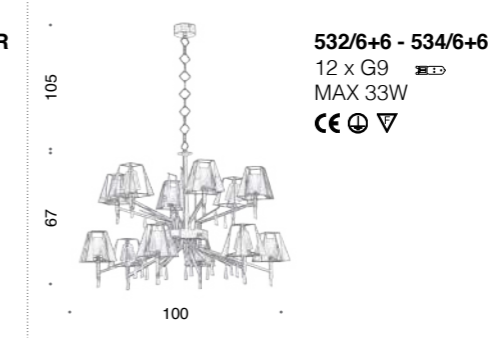
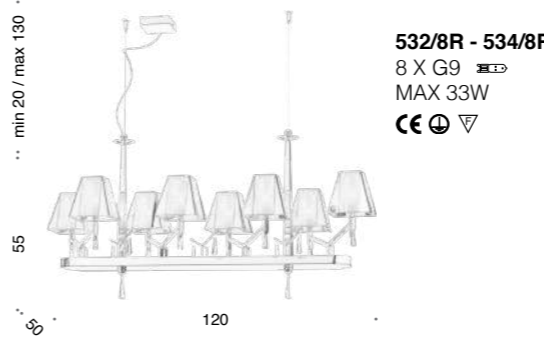

## LAMPADA DA TERA FLOOR LAMP

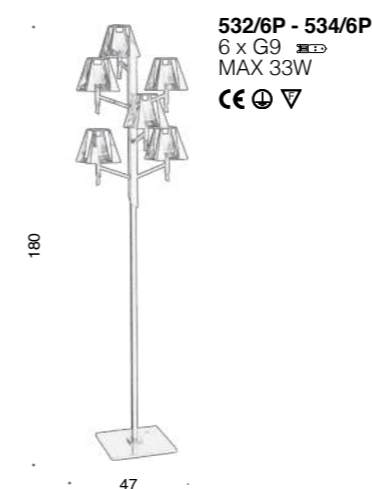

## PLAFONIERA CEILING LAMP



## LAMPADA DA TAVOLO TABLE LAMP



## APPLIQUE WALL BRACKET





# Crystal Rock

DESIGN *Cristian Feltrin*

476/4 sospensione suspension

Modello depositato. Registered design.

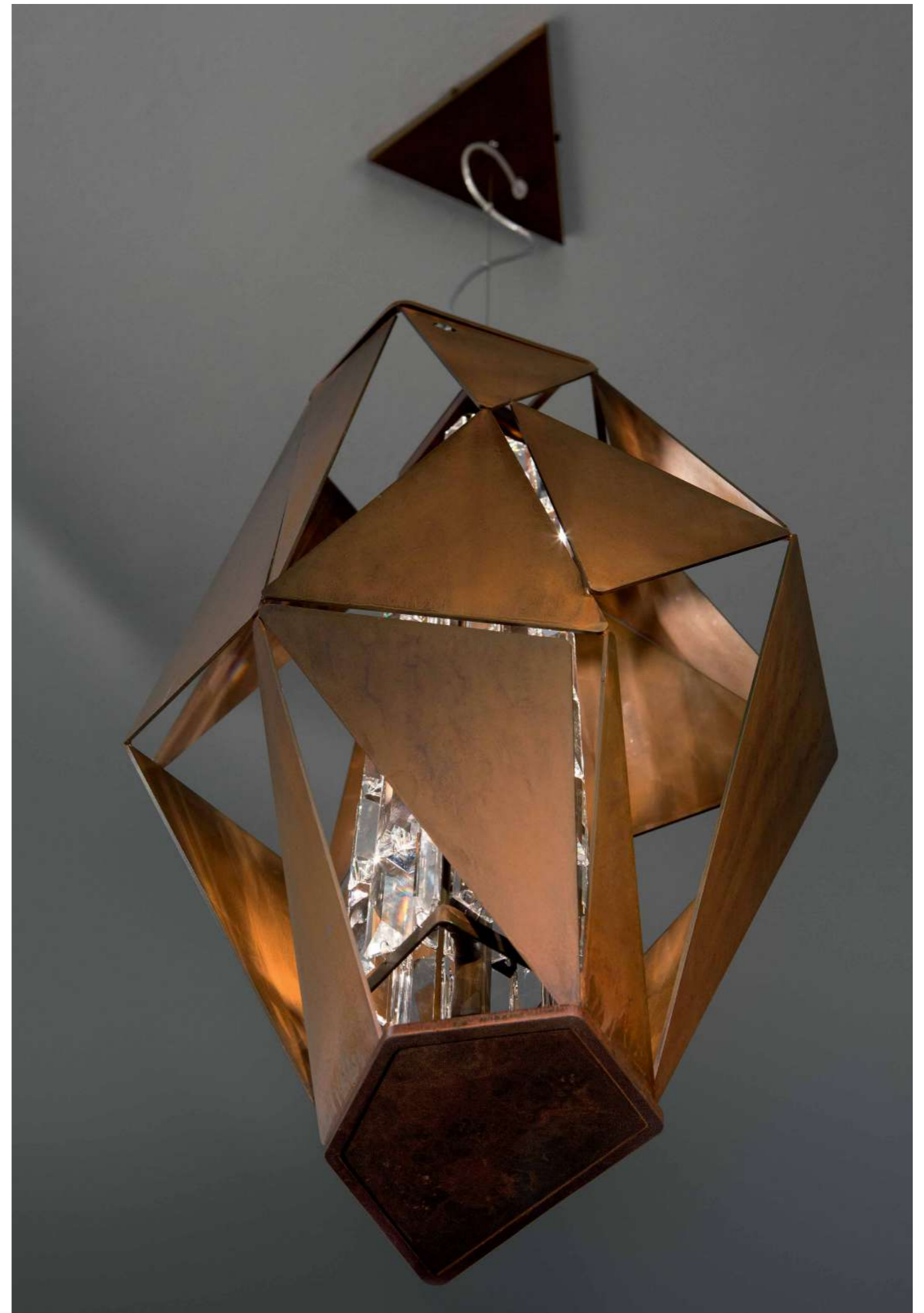

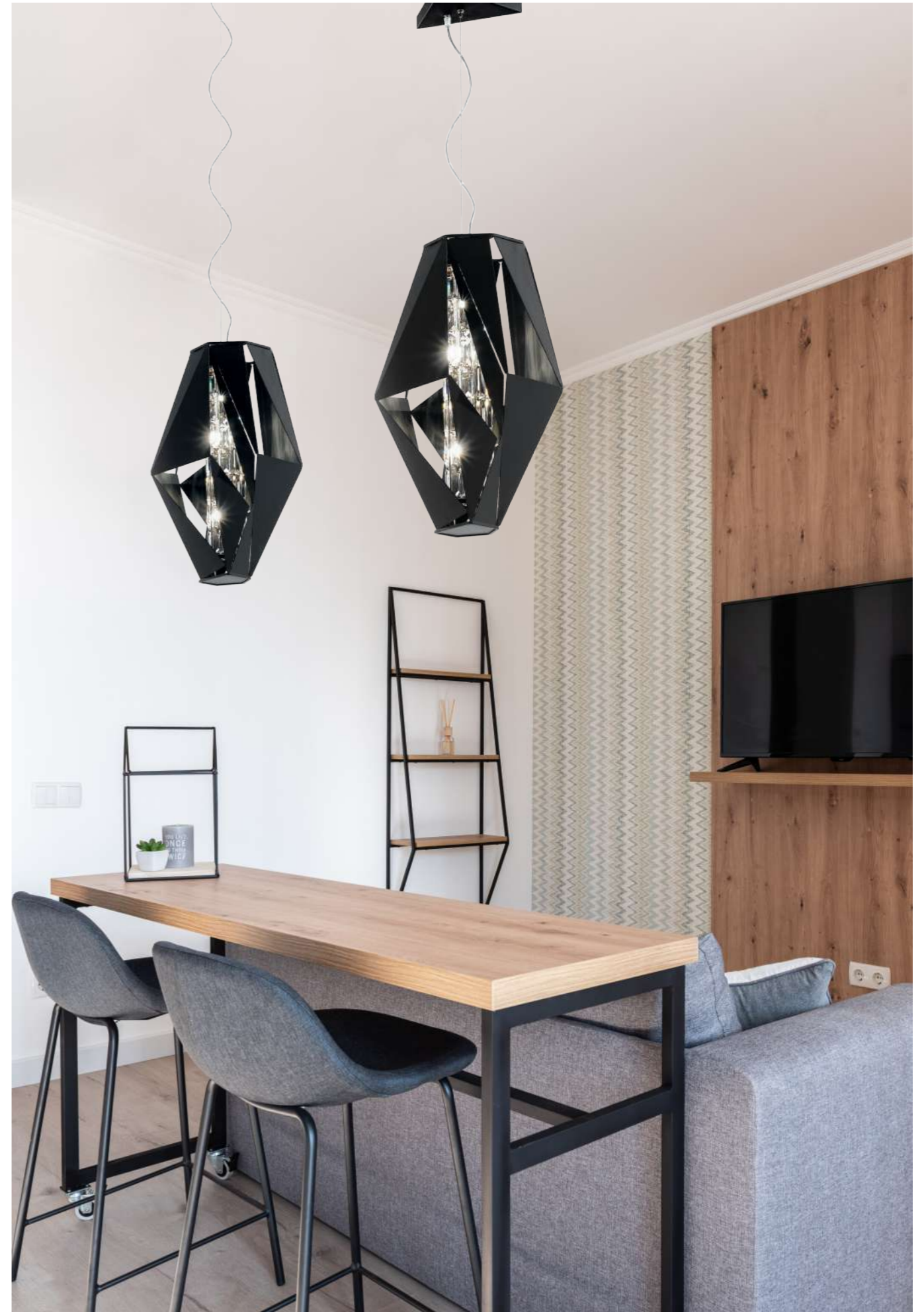



476/4PF plafoniera ceiling lamp



476/4A applique wall bracket



# CRYSTAL ROCK

DESIGN Cristian Feltrin



*nero velluto*  
velvet black

*pure steel*  
pure steel

*ruggine*  
rusty

*oro chiaro*  
light gold

Telaio in metallo, disponibile nelle seguenti finiture:

- nero velluto
- pure steel
- oro chiaro
- ruggine

Metal frame, available in the following finishes:

- velvet black
- pure steel
- light gold
- rusty

La collezione è decorata con cristalli trasparenti.

The collection is decorated with transparent crystals.



## SOSPENSIONE SUSPENSION

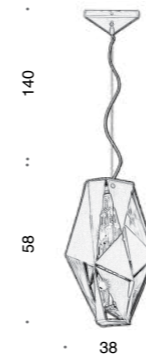

**476/4**  
4 X G9  
MAX 33W  
CE ⊕ ▽

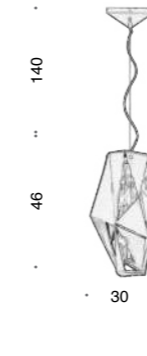

**476/3**  
3 x G9  
MAX 33W  
CE ⊕ ▽

## PLAFONIERA CEILING LAMP



**476/4PF**  
4 x G9  
MAX 33W  
CE ⊕ ▽

## APPLIQUE WALL BRACKET



**476/4A**  
4 x G9  
MAX 33W  
CE ⊕ ▽

## LAMPADA DA TAVOLO TABLE LAMP



**476/2L**  
2 x G9  
MAX 33W  
CE ⊕ ▽



**476/3L**  
3 x G9  
MAX 33W  
CE ⊕ ▽

**476/3L** lampada da tavolo table lamp



# Corten

DESIGN *Cristian Feltrin*

509/6 *sospensione suspension*

Modello depositato. Registered design.

509/4 *sospensione suspension*

509/8 *sospensione suspension*





468/2LED *sospensione suspension*



468/1LED *sospensione suspension*



469/6 *sospensione suspension*



468/120LED *sospensione suspension*

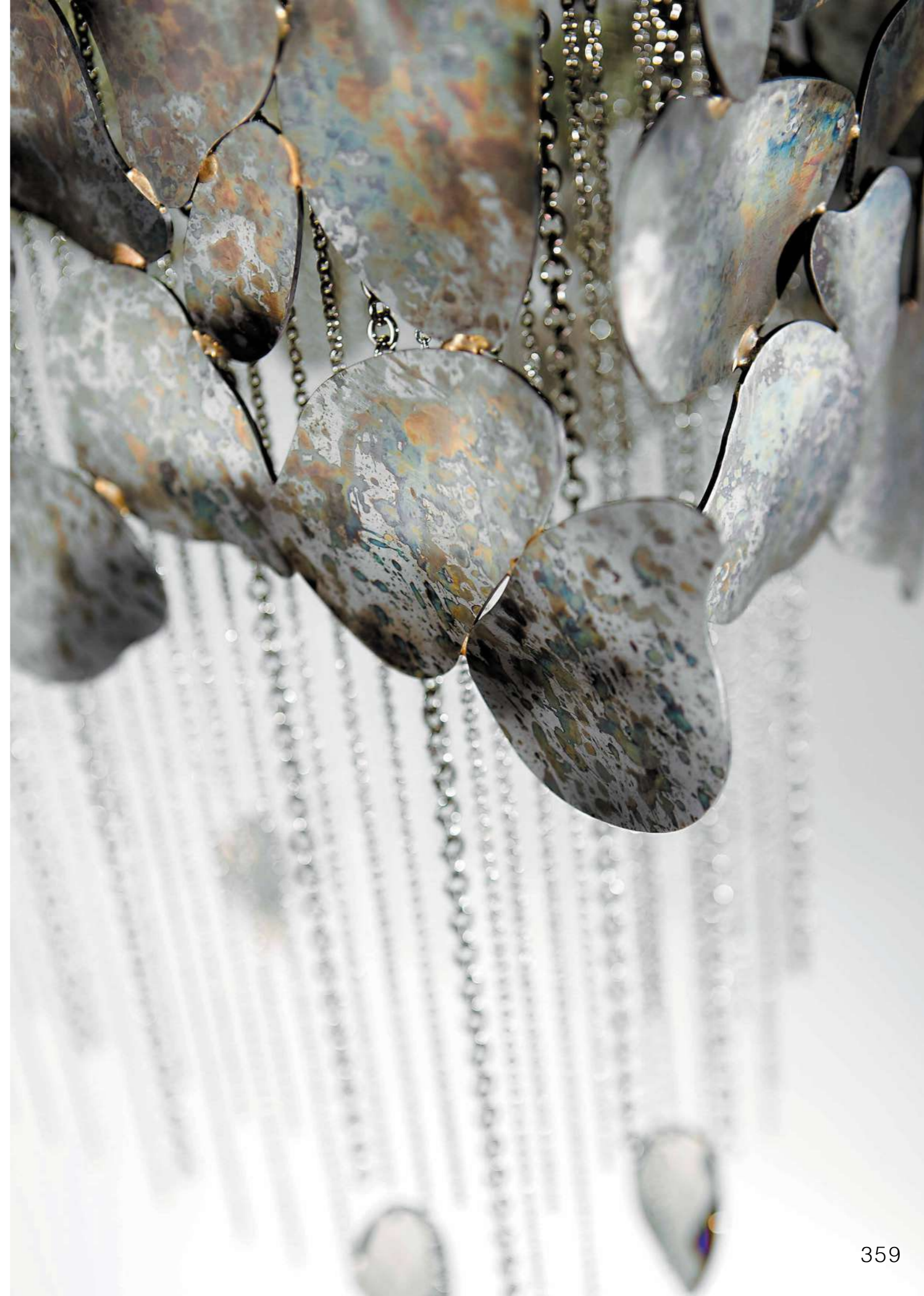



468/72/E *sospensione suspension*



468/50PF/E *plafoniera ceiling lamp*



468/1PFLED plafoniera ceiling lamp



469/6PF plafoniera ceiling lamp



469/3AG applique wall bracket



469/3A applique wall bracket



509/4A-G applique wall bracket

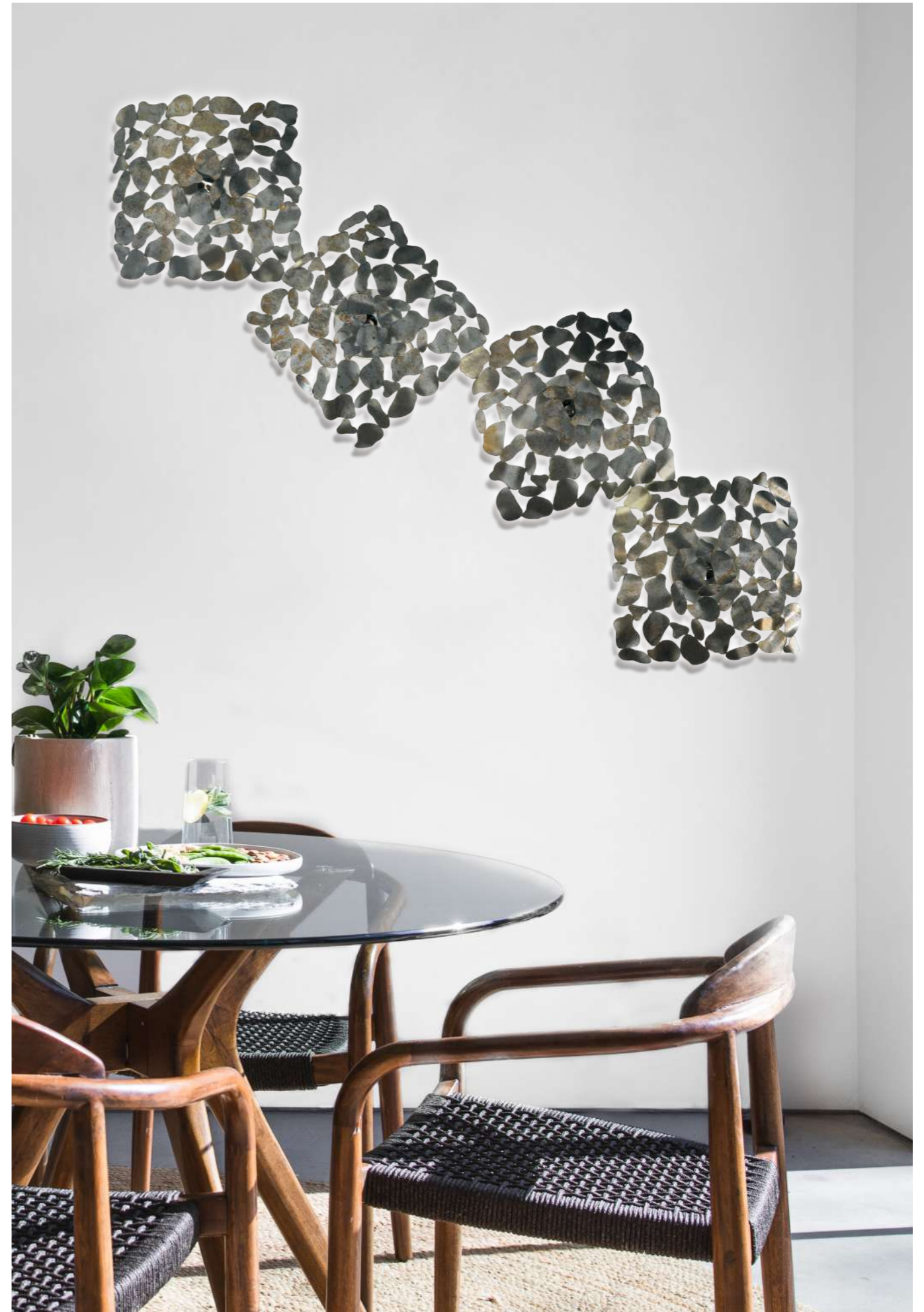

509/16A-M applique wall bracket





509/3L lampada da tavolo table lamp



509/4L lampada da tavolo table lamp

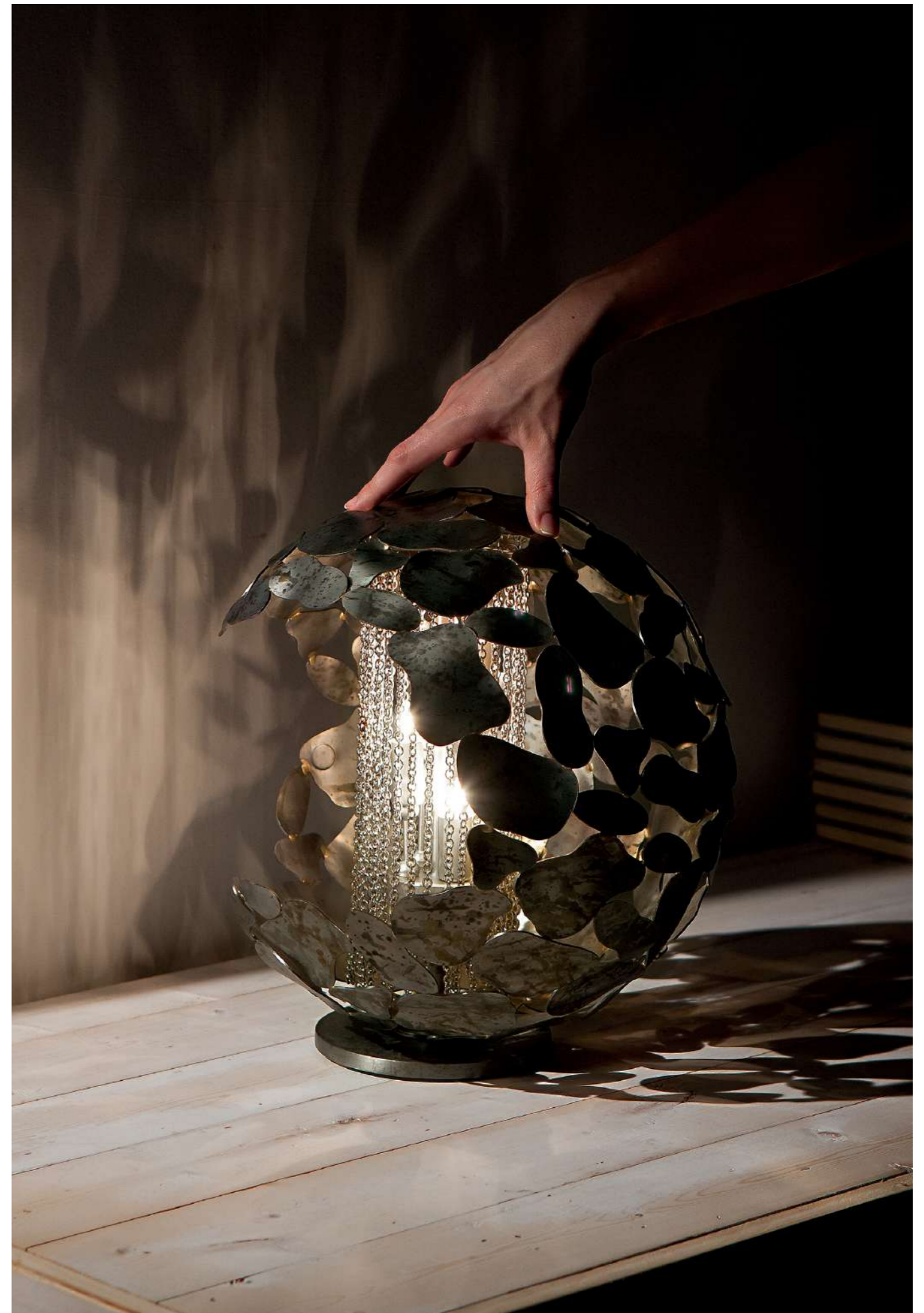



# CORTEN

DESIGN Cristian Feltrin

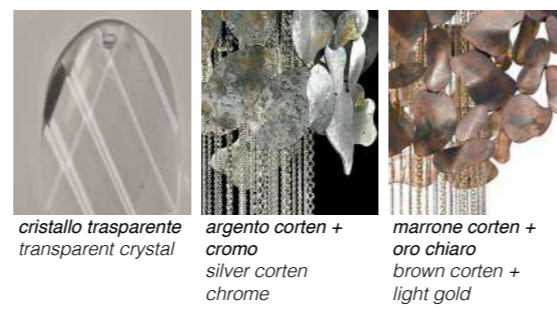

*cristallo trasparente*  
transparent crystal

*argento corten + cromo*  
silver corten  
chrome

*marrone corten + oro chiaro*  
brown corten +  
light gold

La collezione è disponibile nei seguenti abbinamenti colore:  
- argento corten con catene cromate  
- marrone corten con catene oro chiaro

The collection is available in the following colour combinations:  
- silver corten with chromed chains  
- brown corten with golden chains

La collezione è decorata con cristalli trasparenti

The collection is decorated with transparent crystals

## SOSPENSIONE SUSPENSION

 <b>468/120LED</b> 4 x striscia LED 46W 3456 lumen - 3200 K CE ⊕ ▽ <b>469/120</b> 12 x G9 MAX 33W CE ⊕ ▽	 <b>468/2LED</b> 12xLED 2,3W 3564 lumen + 2 LED 2,2W 3000K CE ⊕ ▽ <b>469/12</b> 12 x G9 MAX 33W CE ⊕ ▽	 <b>468/1LED</b> 6xLED 2,3W 1782 lumen + 1 LED 2,2W 3000K CE ⊕ ▽ <b>469/6</b> 6 x G9 MAX 33W CE ⊕ ▽
 <b>468/72/E</b> 3 x E27 MAX 77W CE ⊕ ▽	 <b>468/50/E</b> 2 x E27 MAX 77W CE ⊕ ▽	 <b>468/35/E</b> 1 x E27 MAX 77W CE ⊕ ▽
 <b>509/8</b> 8 x G9 MAX 33W CE ⊕ ▽	 <b>509/6</b> 6 x G9 MAX 33W CE ⊕ ▽	 <b>509/4</b> 4 x G9 MAX 33W CE ⊕ ▽

## PLAFONIERA CEILING LAMP

 <b>468/72PF/E</b> 3 x E27 MAX 77W CE ⊕ ▽	 <b>468/50PF/E</b> 2 x E27 MAX 77W CE ⊕ ▽	 <b>468/35PF/E</b> 1 x E27 MAX 77W CE ⊕ ▽
 <b>468/1PFLED</b> 6xLED 2,3W 1782 lumen + 1 LED 2,2W 3000K CE ⊕ ▽ <b>469/6PFG</b> 6 x G9 MAX 33W CE ⊕ ▽	 <b>469/6PF</b> 6 x G9 MAX 33W CE ⊕ ▽	

## APPLIQUE WALL BRACKET

 <b>469/3A</b> 3 x G9 MAX 33W CE ⊕ ▽	 <b>469/3AG</b> 3 x G9 MAX 33W CE ⊕ ▽	 <b>509/16A-G</b> glass <b>509/16A-M</b> metal 16 LED max 2,3W 3840 lumen - 3000 K CE ⊕ ▽ Punto di connessione solo in A o B Electrical connection in A or B position only
--	---	---

 <b>509/4A-G</b> glass <b>509/4A-M</b> metal 4 LED max 2,3W 1440 lumen - 3000 K CE ⊕ ▽
---

## LAMPADA DA TAVOLO TABLE LAMP

 <b>469/1L</b> 1 x G9 MAX 33W CE ⊕ ▽	 <b>509/4L</b> 4 x G9 MAX 33W CE ⊕ ▽	 <b>509/3L</b> 3 x G9 MAX 33W CE ⊕ ▽
--	--	--

## LAMPADA DA TERRA FLOOR LAMP

 <b>468/PLED</b> 2 x striscia LED 40,5W 3024 lumen - 3000 K CE ⊕ ▽
--

La finitura CORTEN (argento o marrone) è un procedimento di ossidazione naturale. La realizzazione di tale processo è influenzata dal livello di umidità, dalla temperatura esterna e da altre variabili ambientali. La mano dell'uomo e la specifica lavorazione sono il valore aggiunto che testimonia l'autentico 'Made in Italy'. Come tutte le opere dove il procedimento non è meccanico ma artigianale le eventuali variazioni di colore non sono da considerarsi un difetto ma una testimonianza dell'unicità del prodotto. La finitura Corten rende quindi il prodotto unico e irripetibile. Le foto presenti nel nostro catalogo costituiscono solo un'identificazione del tipo di prodotto e non rappresentano un campione degli stessi.

The finish CORTEN (silver or brown) is the result of a procedure of natural oxidation. The procedure is every time affected by the percentage of humidity in the air, by the external temperature and by other environmental variables. Hands of man and a special processing are a value added, which is evidence of the real 'Made in Italy'. As in all works where the procedure is not mechanical but handcrafted, variations are possible, but they must not be considered as a defect, but rather as a proof of the uniqueness of the product. Corten finish makes the product as unique, since every results is not reproducible in identical way. The pictures of our catalogues are only an example of the kind of the product, but they cannot be considered strictly as samples of them, since the result can be different.

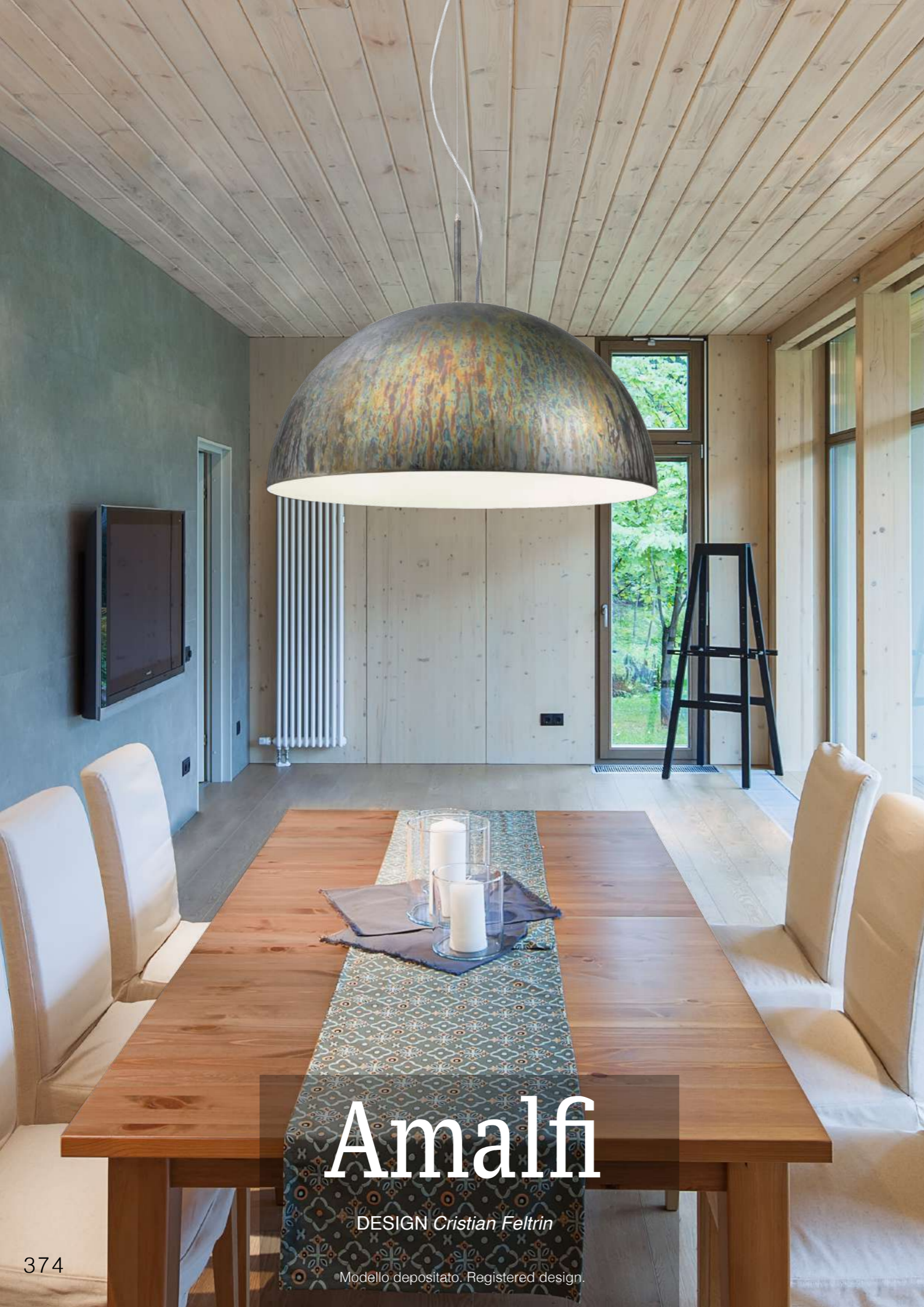

# Amalfi

DESIGN *Cristian Feltrin*

Modello depositato. Registered design.



482/50 *sospensione suspension*



482/50 *sospensione suspension*



482/72 *sospensione suspension*



482/90 *sospensione suspension*



482/72 *sospensione suspension*

# AMALFI

DESIGN Cristian Feltrin

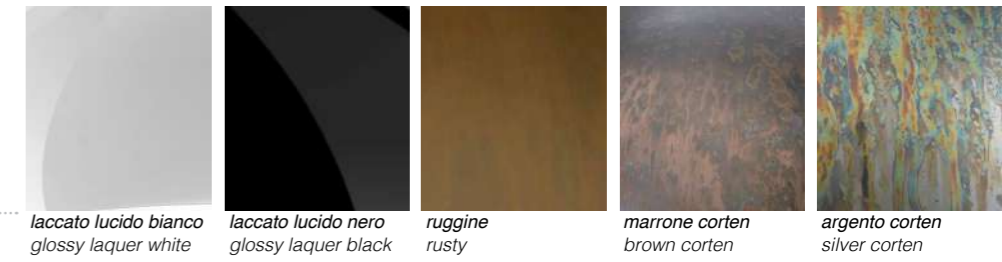





L'interno di ogni articolo è disponibile nei colori:  
The inside of each items is available in the colours:

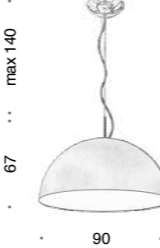

Telaio in metallo disponibile nelle finiture come da cartella colore.  
L'interno di ogni articolo è disponibile nei colori bianco satinato, foglia oro o foglia argento.  
Diffusore in policarbonato satinato.  
Nota: nelle sospensioni con 1 x E27 il diffusore non è applicato.

Metal frame available in finishes as per colour card.  
The inside of each items is available in the colours satin white, gold or silver leaf.  
Satin polycarbonate diffuser.  
Note: on suspensions with 1 x E27 the diffuser is not applied.

## SOSPENSIONE SUSPENSION

 <p>max 140 67 90</p>	<p><b>482/90</b> 12 x LED 2,3W 3564 lumen - 2700K CE ⊕ ▽</p>	<p><b>478/90/E</b> 4 x E27 MAX 46W CE ⊕ ▽</p>	 <p>max 140 49 72</p>	<p><b>482/72</b> 10 x LED 2,3W 2970 lumen - 2700K CE ⊕ ▽</p>	<p><b>478/72/E</b> 3 x E27 MAX 46W CE ⊕ ▽</p>
 <p>max 140 38 50</p>	<p><b>482/50</b> 8 x LED 2,3W 2376 lumen - 2700K CE ⊕ ▽</p>	<p><b>478/50/E</b> 2 x E27 MAX 30W CE ⊕ ▽</p>	 <p>max 140 31 35</p>	<p><b>482/35</b> 4 x LED 2,3W 1188 lumen - 2700K CE ⊕ ▽</p>	<p><b>478/35/E</b> 1 x E27 MAX 30W CE ⊕ ▽</p>

## PLAFONIERA CEILING LAMP

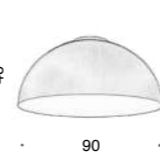
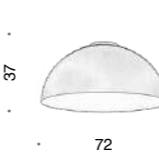
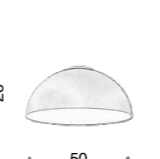
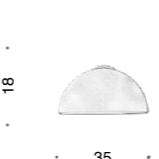
 <p>46 90</p>	<p><b>482/90PF</b> 12 x LED 2,3W 3564 lumen - 2700K CE ⊕ ▽</p>	<p><b>478/90PF/E</b> 4 x E27 MAX 46W CE ⊕ ▽</p>	 <p>37 72</p>	<p><b>482/72PF</b> 10 x LED 2,3W 2970 lumen - 2700K CE ⊕ ▽</p>	<p><b>478/72PF/E</b> 3 x E27 MAX 46W CE ⊕ ▽</p>
 <p>26 50</p>	<p><b>482/50PF</b> 8 x LED 2,3W 2376 lumen - 2700K CE ⊕ ▽</p>	<p><b>478/50PF/E</b> 2 x E27 MAX 30W CE ⊕ ▽</p>	 <p>18 35</p>	<p><b>482/35PF</b> 4 x LED 2,3W 1188 lumen - 2700K CE ⊕ ▽</p>	<p><b>478/35PF/E</b> 1 x E27 MAX 30W CE ⊕ ▽</p>

482/35PF plafoniera ceiling lamp

482/50PF plafoniera ceiling lamp

La finitura CORTEN (argento o marrone) è un procedimento di ossidazione naturale. La realizzazione di tale processo è influenzata dal livello di umidità, dalla temperatura esterna e da altre variabili ambientali. La mano dell'uomo e la specifica lavorazione sono il valore aggiunto che testimonia l'autentico 'Made in Italy'. Come tutte le opere dove il procedimento non è meccanico ma artigianale le eventuali variazioni di colore non sono da considerarsi un difetto ma una testimonianza dell'unicità del prodotto. La finitura Corten rende quindi il prodotto unico e irripetibile. Le foto presenti nel nostro catalogo costituiscono solo un'identificazione del tipo di prodotto e non rappresentano un campione degli stessi.

The finish CORTEN (silver or brown) is the result of a procedure of natural oxidation. The procedure is every time affected by the percentage of humidity in the air, by the external temperature and by other environmental variables. Hands of man and a special processing are a value added, which is evidence of the real 'Made in Italy'. As in all works where the procedure is not mechanical but handcrafted, variations are possible, but they must not be considered as a defect, but rather as a proof of the uniqueness of the product. Corten finish makes the product as unique, since every results is not reproducible in identical way. The pictures of our catalogues are only an example of the kind of the product, but they cannot be considered strictly as samples of them, since the result can be different.



# Stardust

DESIGN *Cristian Feltrin*

608SR/10+8 *sospensione suspension*

Modello depositato. Registered design.



608R/7+6 *sospensione suspension*





608/8+1SL *sospensione suspension*

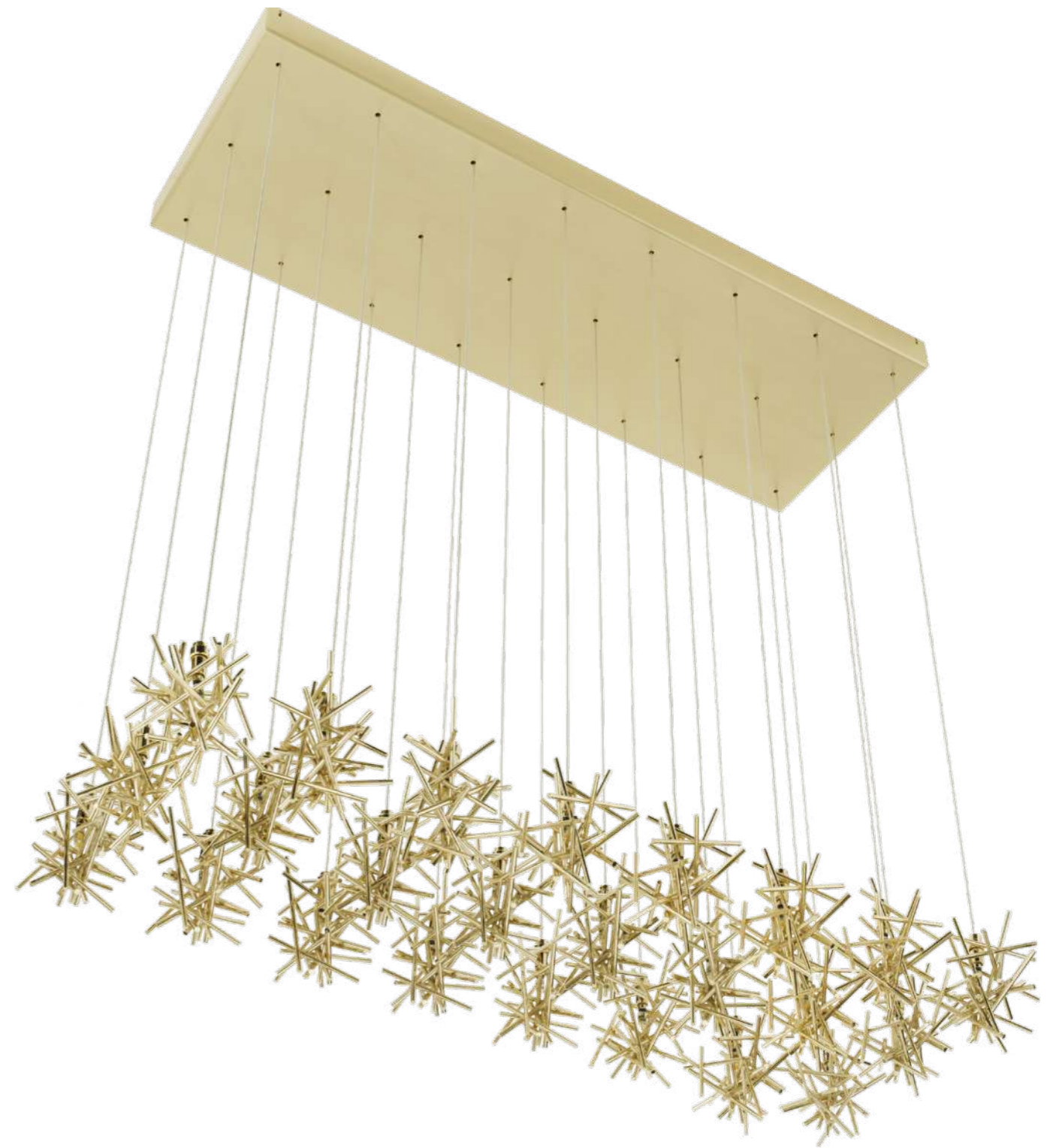

610/24 *sospensione suspension*



610/9 *sospensione suspension*



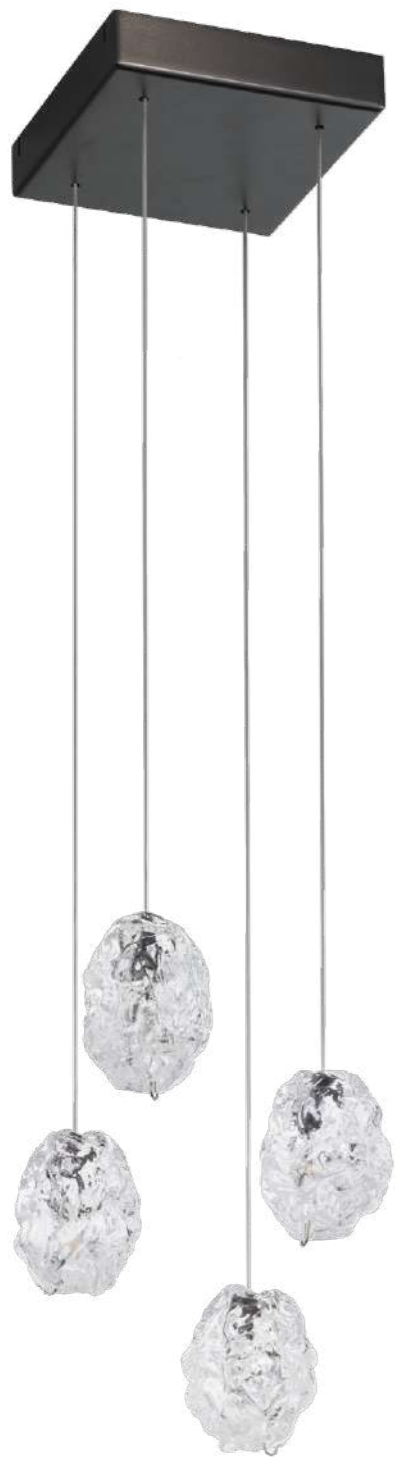

609/4 *sospensione suspension*



610/4 *sospensione suspension*

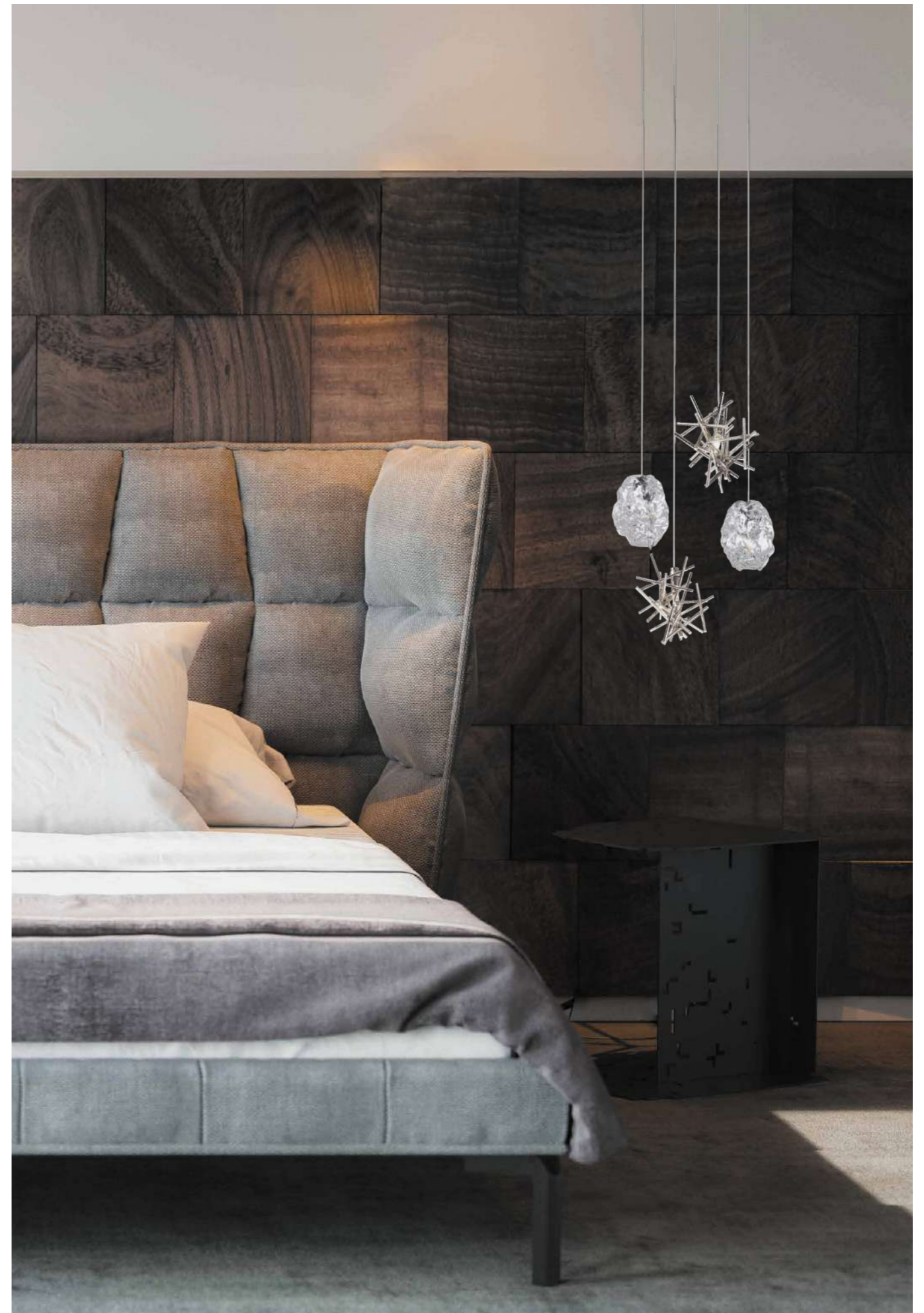

608/2+2 *sospensione suspension*



609/3A applique wall bracket



610/3A applique wall bracket



609/9 sospensione suspension

# STARDUST

DESIGN Cristian Feltrin



oro chiaro spazzolato opaco  
brushed matt light gold

nichel bianco spazzolato opaco  
brushed matt nickel

bianco velluto  
velvet white

ruggine  
rusty

nichel nero spazzolato opaco  
brushed matt black nickel

oro chiaro  
light gold \*\*

pure steel  
pure steel \*\*

vetro Sasso trasparente  
Sasso transparent glass

Nido pure steel  
Nido pure steel

Nido oro chiaro  
Nido light gold



Telaio disponibile nelle finiture oro chiaro spazzolato opaco, nichel bianco spazzolato opaco, bianco velluto, ruggine, nichel nero spazzolato opaco. Il vetro Sasso è disponibile in trasparente e il Nido in metallo è disponibile in pure steel o oro chiaro.

In base alla combinazione scelta, il codice articolo cambierà:  
art.608: versione Sasso+Nido  
art.609: versione solo Sasso  
art.610: versione solo Nido.





Esempio: articolo 608/ (numero vetri Sasso) + (numero Nido in metallo)  
\*\* Telaio disponibile anche nella finitura oro chiaro o pure steel.

Frame available in brushed matt light gold, brushed matt nickel, velvet white, rusty, brushed matt black nickel. The "Sasso" is available in transparent glass and the "Nido" is available in pure steel or light gold metal.

Depending on the combination you choose, the item code will change:  
art.608: version Sasso glass + Nido metal  
art.609: version Sasso glass only  
art.610: version Nido metal only

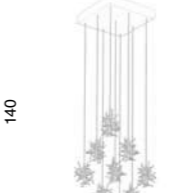
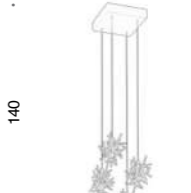
Example: item 608/ (number of glass Sasso) + (number of metal Nido)  
\*\* Frame available also in light gold or pure steel.

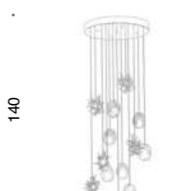
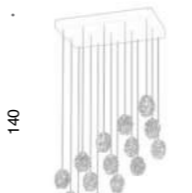
## SOSPENSIONE SUSPENSION

 <p><b>610/24</b> 24 x G4 LED 1,42W 12V 2.400 lumen 2800K CE ⊕ ▽ driver 0 - 60W MAX 98X33</p>	 <p><b>610/9 - 609/9</b> 9 x G4 LED 1,42W 12V 900 lumen 2800K CE ⊕ ▽ driver 0 - 30W MAX 33X33</p>	 <p><b>610/4 - 609/4</b> 4 x G4 LED 1,42W 12V 400 lumen 2800K CE ⊕ ▽ driver 0 - 30W MAX 20X20</p>
 <p><b>608/8+1SL</b> 9 x G4 LED 1,42W 12V 900 lumen 2800K CE ⊕ ▽ driver 0 - 30W MAX 110 33</p>	 <p><b>608SR/10+8 **</b> 18 x G4 LED 1,42W 12V 1.800 lumen 2800K CE ⊕ ▽ driver 0 - 60W MAX 150 90</p>	 <p><b>608R/7+6 **</b> 13 x G4 LED 1,42W 12V 1.300 lumen 2800K CE ⊕ ▽ driver 0 - 60W MAX 45</p>
 <p><b>609/15</b> 15 x G4 LED 1,42W 12V 1.500 lumen 2800K CE ⊕ ▽ driver 0 - 60W MAX 59X33</p>	 <p><b>608/2+2</b> 4 x G4 LED 1,42W 12V 400 lumen 2800K CE ⊕ ▽ driver 0 - 30W MAX 20X20</p>	

## APPLIQUE WALL BRACKET

 <p><b>609/1A - 610/1A</b> 1 x G4 LED 1,42W 12V 100 lumen 2800K or CE ⊕ ▽ driver 0 - 30W MAX 40 13</p>	 <p><b>609/3A - 610/3A</b> 3 x G4 LED 1,42W 12V 300 lumen 2800K or CE ⊕ ▽ driver 0 - 30W MAX 40 38</p>
---	---

609/1A applique wall bracket

610/1A applique wall bracket



# Nuvola

DESIGN *Cristian Feltrin*

372/8S *sospensione suspension*

Modello depositato. Registered design.

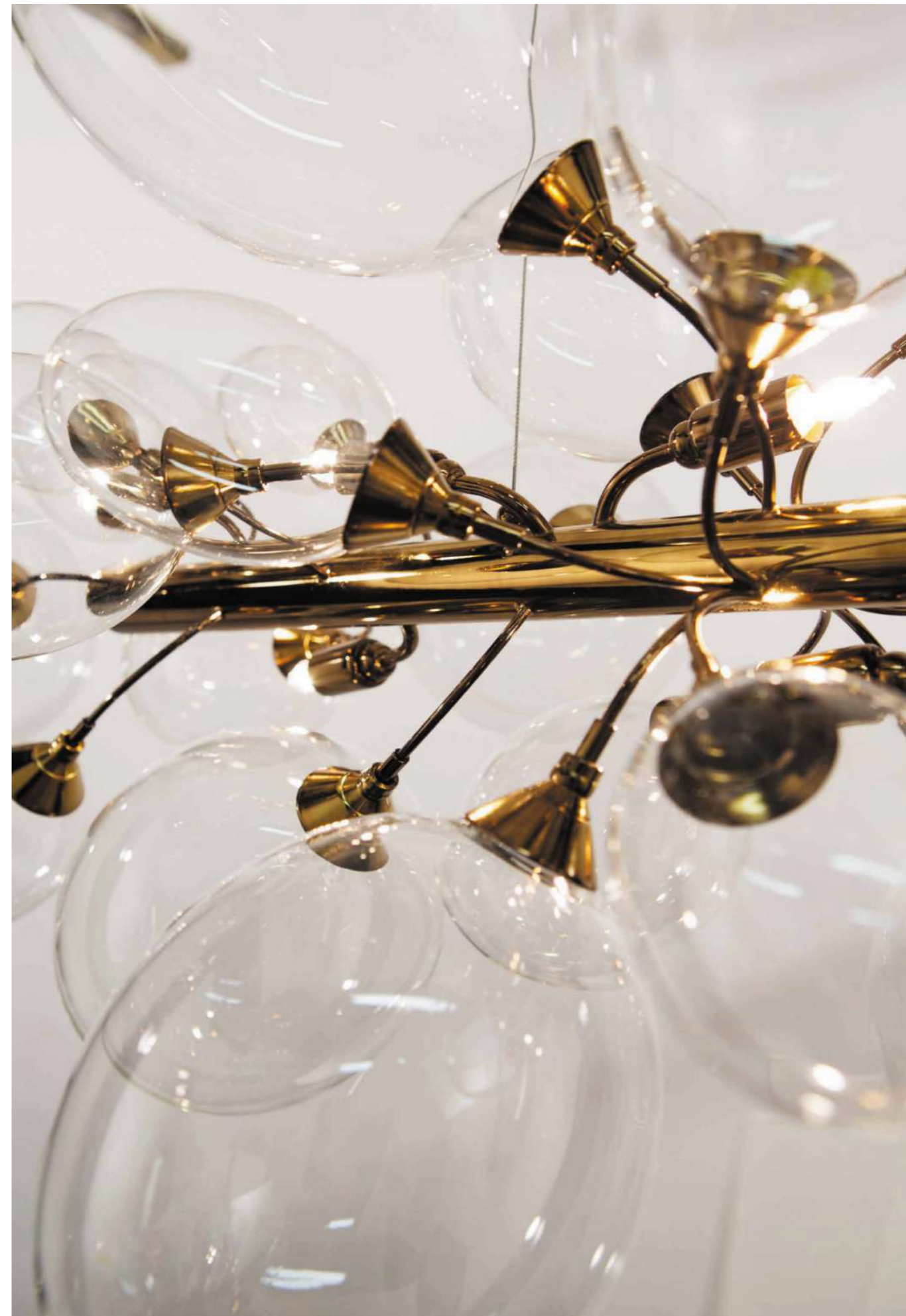



**380/6S** *sospensione suspension*



**380/1S** *sospensione suspension*



372/8PF plafoniera ceiling lamp



372/2A-PF applique - plafoniera wall bracket - ceiling lamp



# NUVOLA

DESIGN Silvio Longhin & Antonio Piva



bronzo scuro  
dark bronze

nichel nero opaco  
matt black nickel

cromo  
chrome

## APPLIQUE WALL BRACKET



**372/2A-PF**  
2 x G9  
MAX 33W  
CE ⊕ ▽

## LAMPADA DA TAVOLO TABLE LAMP



**372/3L**  
3 x G9  
MAX 33W  
CE ⊕ ▽



**380/3L**  
3 x G9  
MAX 33W  
CE ⊕ ▽

## LAMPADA DA TERRA FLOOR LAMP



**372/8P**  
8 x G9  
MAX 33W  
CE ⊕ ▽

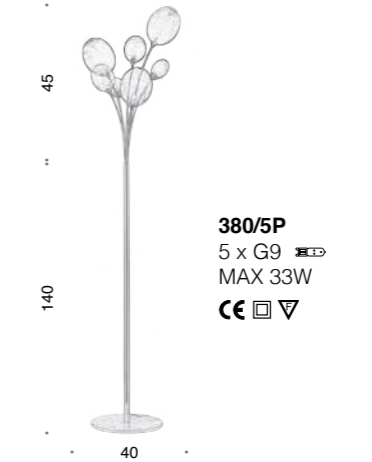

**380/5P**  
5 x G9  
MAX 33W  
CE ⊕ ▽

## SOSPENSIONE SUSPENSION

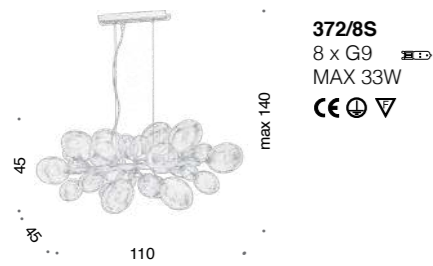

**372/8S**  
8 x G9  
MAX 33W  
CE ⊕ ▽



**372/6S**  
6 x G9  
MAX 33W  
CE ⊕ ▽



**380/8S**  
8 x G9  
MAX 33W  
CE ⊕ ▽

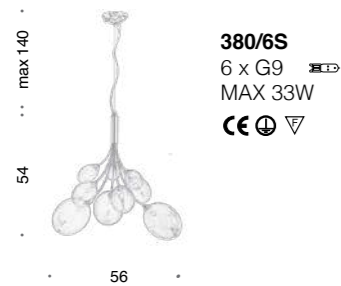

**380/6S**  
6 x G9  
MAX 33W  
CE ⊕ ▽

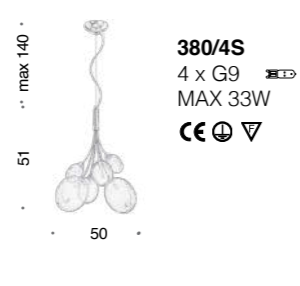

**380/4S**  
4 x G9  
MAX 33W  
CE ⊕ ▽

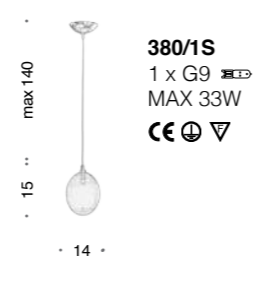

**380/1S**  
1 x G9  
MAX 33W  
CE ⊕ ▽

## PLAFONIERA CEILING LAMP



**372/8PF**  
8 x G9  
MAX 33W  
CE ⊕ ▽



**372/6PF**  
6 x G9  
MAX 33W  
CE ⊕ ▽



**380/8PF**  
8 x G9  
MAX 33W  
CE ⊕ ▽

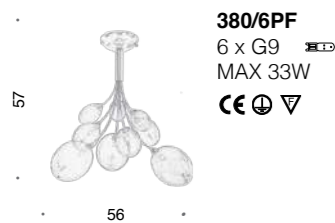

**380/6PF**  
6 x G9  
MAX 33W  
CE ⊕ ▽

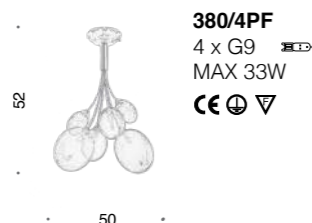

**380/4PF**  
4 x G9  
MAX 33W  
CE ⊕ ▽



# Bamboo

497/12 *sospensione suspension*

DESIGN *IDL Staff*

Modello depositato. Registered design.



497/8 *sospensione suspension*





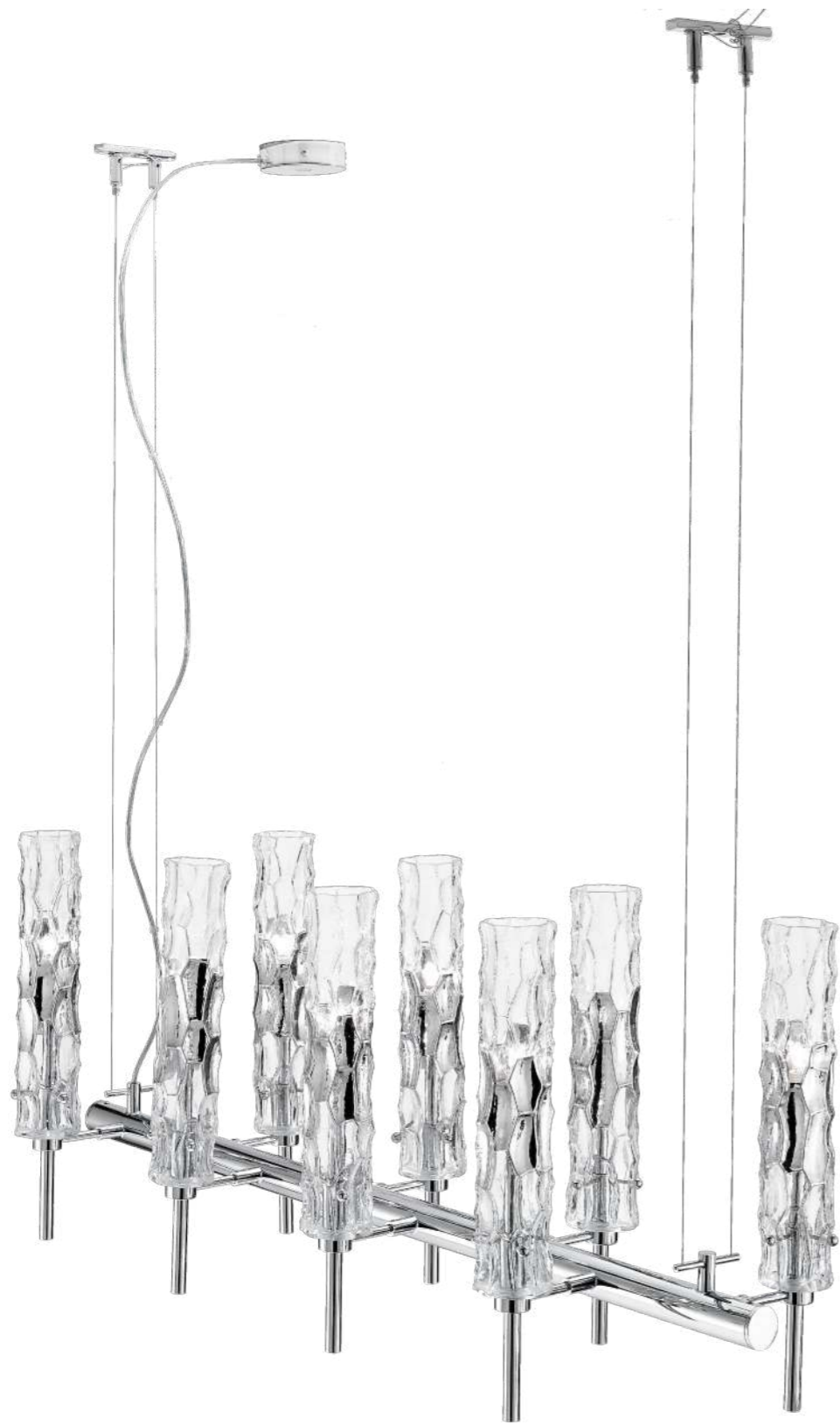

496/8 *sospensione suspension*



423/6 *sospensione suspension*



423/10PF plafoniera ceiling lamp



423/1S sospensione suspension

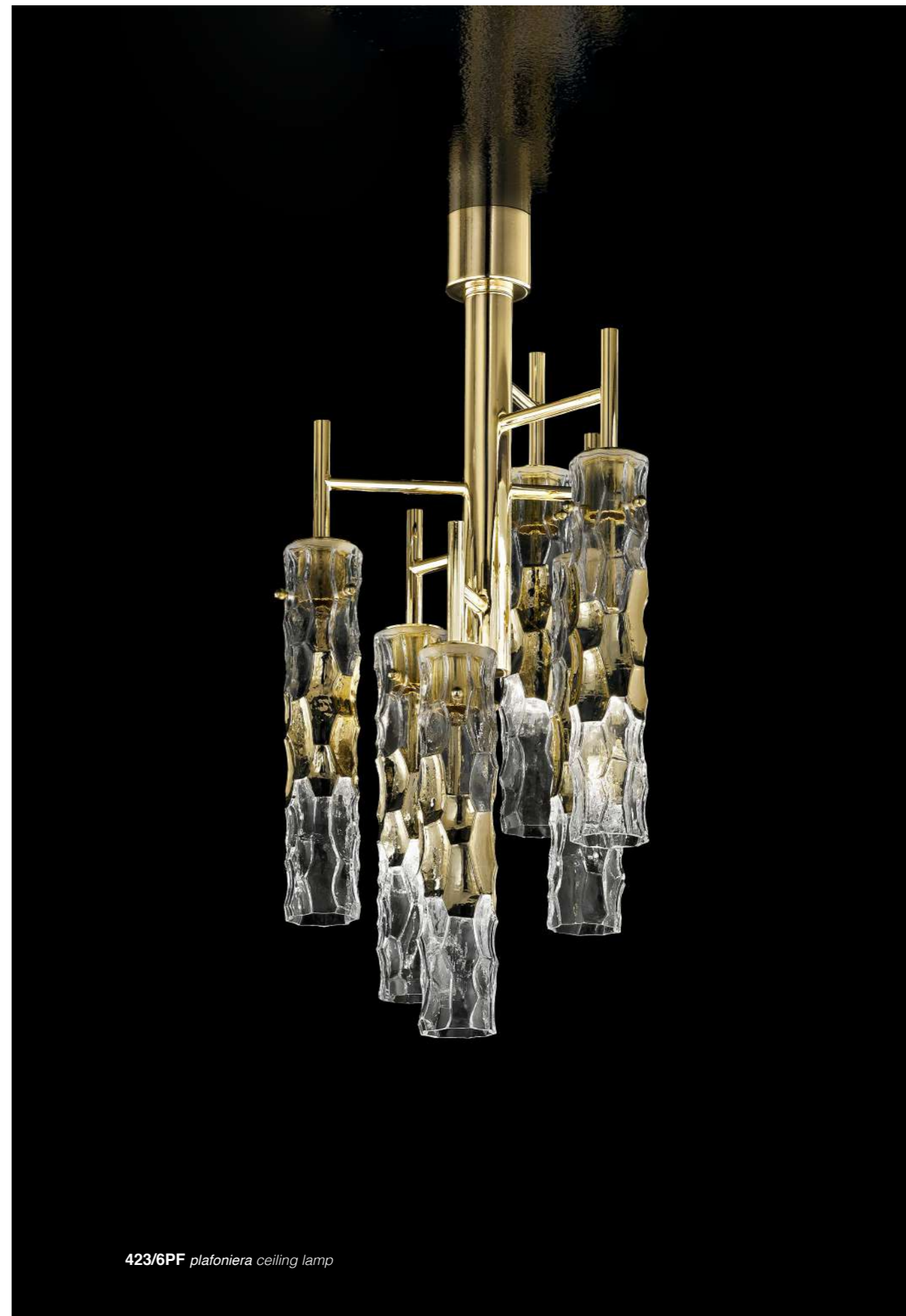

423/6PF plafoniera ceiling lamp



423/35 *sospensione suspension*

*disponibili realizzazioni su misura custom made size available*



423/3L *lampada da tavolo table lamp*



423/1L *lampada da tavolo table lamp*





423/2ADX applique wall bracket



423/2ASX applique wall bracket

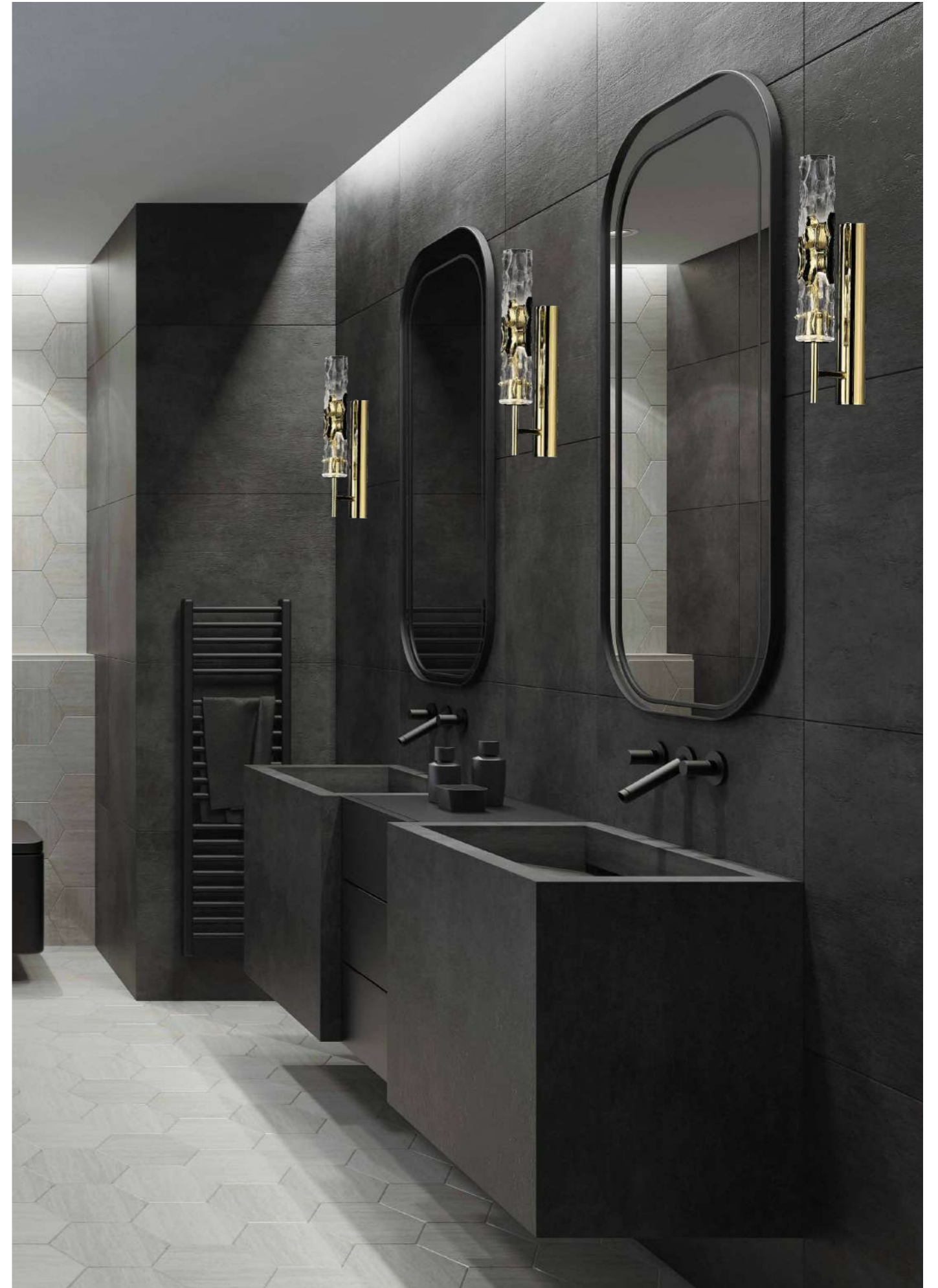

423/1A applique wall bracket



423B/1LG lampada da tavolo table lamp



423B/1LP lampada da tavolo table lamp



423/3P lampada da terra floor lamp



423B/4P lampada da terra floor lamp



423B/5P lampada da terra floor lamp

# BAMBOO

DESIGN IDL staff



placcato oro 24kt  
24kt gold plated

cromo  
chrome

nichel nero satinato  
satin black nickel

nichel nero  
black nickel



cromo  
chrome

trasparente  
clear

trasparente con  
banda cromo  
clear with band  
chrome

trasparente con  
banda oro  
clear with band  
gold



chinette avorio  
chinette ivory

lamé argento  
lamé silver

lamé oro  
lamé gold

Telaio in metallo disponibile nelle seguenti finiture:

- cromo
- placcato oro 24kt
- nichel nero satinato
- nichel nero

Tubi in vetro di Murano lavorato con effetto martellato disponibile:

- con fascia decorativa metallizzata cromo o oro
- completamente metallizzato cromo
- completamente trasparente

Nelle sospensioni a cavo, i cavi sono in acciaio inox.

I paralumi in tessuto sono disponibili nelle seguenti varianti:

- chinette avorio
- lamé argento o oro

Metal frame available in the following finishes:

- chrome finish
- 24kt gold plated
- satin black nickel
- black nickel

Tubes in Murano glass worked with hammered effect available:

- with decorative band chrome or gold
- all in chrome
- all in clear

In the suspensions with cables, the cables are in stainless steel.







Fabric lampshades are available in the following versions:

- chinette ivory
- lamé silver or gold

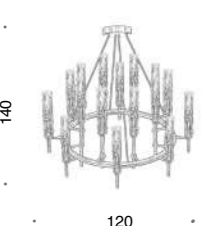
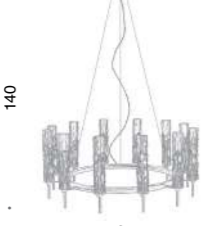

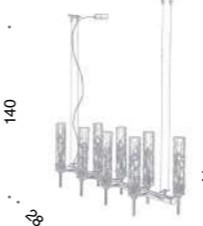
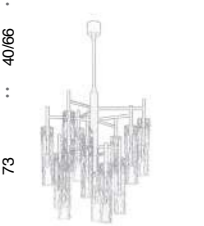
## LAMPADA DA TAVOLO TABLE LAMP

 <b>423/3L</b> 3 x G9 LED MAX 20W CE ⊕ ▽	 <b>423/1L</b> 1 x G9 LED MAX 20W CE ⊕ ▽	 <b>423B/1LG</b> 1 x E27 MAX 77W CE ⊕ ▽	 <b>423B/1LP</b> 1 x E27 MAX 77W CE ⊕ ▽
---	---	--	--

## SOSPENSIONE SUSPENSION

 <b>497/8+8</b> 16 x G9 LED MAX 20W CE ⊕ ▽	 <b>497/12</b> 12 x G9 LED MAX 20W CE ⊕ ▽	 <b>497/8</b> 8 x G9 LED MAX 20W CE ⊕ ▽	 <b>496/8</b> 8 x G9 LED MAX 20W CE ⊕ ▽
 <b>423/12</b> 12 x G9 LED MAX 20W CE ⊕ ▽	 <b>423/8</b> 8 x G9 LED MAX 20W CE ⊕ ▽	 <b>423/6</b> 6 x G9 LED MAX 20W CE ⊕ ▽	 <b>423/3</b> 3 x G9 LED MAX 20W CE ⊕ ▽



## LAMPADA DA TERRA FLOOR LAMP

 <b>423/3P</b> 3 x G9 LED MAX 20W CE ⊕ ▽	 <b>423B/5P</b> 1 x E27 MAX 77W CE ⊕ ▽	 <b>423B/4P</b> 1 x E27 MAX 77W CE ⊕ ▽
--	--	--

## APPLIQUE WALL BRACKET

 <b>423/1A</b> 1 x G9 LED MAX 20W CE ⊕ ▽
 <b>423/2ADX</b> 2 x G9 LED MAX 20W CE ⊕ ▽
 <b>423/2ASX</b> 2 x G9 LED MAX 20W CE ⊕ ▽
 <b>423/3A</b> 3 x G9 LED MAX 20W CE ⊕ ▽

## COLONNA COLUMN \*

 <b>423/35</b> 6 x GU10 LED MAX 4,6W 2700K CE ⊕ ▽	 <b>423/66</b> 9 x GU10 LED MAX 4,6W 2700K CE ⊕ ▽
---	---

\* disponibili realizzazioni su misura

\* custom made sizes available

Codice Articolo	Pagina	Codice Articolo	Pagina
Article code	Page	Article code	Page
<b>ROMA</b>		430/65PF	265
359/1L	212-213	430/90PF	262-263-265
359/1SP	213	430/100	257-265
359/2A	210-213	430/120	265
359/4A	211-213	430/120PF	265
359/4P	207-213	<b>NINFEA</b>	
359/4S	205-213	436/4+1A	291-293
359/5R	203-213	436/5L	292-293
359/5S	206-213	436/5P	289-293
359/5SP	208-209-213	436/10+1	293
359/14	200-201-213	436/10+1PF	290-293
359/22	202-213	436/18+1	286-287-288-293
359/42	213	436/18+1PF	293
359/90X90	204-213	<b>DIVINA</b>	
<b>NUVOLA</b>		439/3+2A	298-303
372/2A-PF	399-401	439/3L	303
372/3L	401	439/6	295-303
372/6S	400	439/6A	299-303
372/8P	401	439/6L	297-301-303
372/8PF	400	439/9	296-303
372/8S	400	439/9P	302-303
380/1S	397-400	439/12	294-303
380/3L	401	<b>CHRYSALIS</b>	
380/4PF	401	448/1LG	166-171
380/4S	400	448/3	170
380/5P	401	448/3+3	170
380/6PF	400	448/3ADX	164-171
380/6S	396-400	448/3AG	165-171
380/8PF	398-400	448/3ASX	164-171
380/8S	394-400	448/3L	167-171
<b>BAMBOO</b>		448/3PF	161-171
423/1A	419-425	448/3+3PF	171
423/1L	415-425	448/5	152-170
423/1S	411-424	448/5+3	152-153-170
423/2ADX	418-425	448/5PF	171
423/2ASX	418-425	448/5+3-PF	161-171
423/3	425	448/5L	167-171
423/3A	405-407-425	448/6	152-170
423/3L	415-425	448/6+3	152-153-170
423/3P	421-425	448/6P	171
423/3PF	424	448/6+5P	168-169-171
423/6	405-424	448/8	160-170
423/6PF	413-424	448/8+3	170
423/8	406-424	448/8PF	171
423/8PF	424	448/8SLED	154-155-170
423/10PF	410-424	448/8+3PF	171
423/12	404-424	448/27	158-159-170
423/12PF	424	448/84PF	163-171
423/35	414-425	448/115	170
423/66	416-425	448/2000LED	156-167-170
423B/1LG	420-425	448SPOT	162-171
423B/1LP	420-425	<b>GROOVY</b>	
423B/4P	422-425	463/1A	115-121-123
423B/5P	423-425	463/1L	119-123
<b>PARADISE</b>		463/1P	111-123
430/1L	261-265	463/2AP	123
430/1P	264-265	463/6	118-123
430/2ADX	258-265	463/8PF	120-123
430/2ASX	255-265	463/10	117-123
430/4A	258-265	463/10PF	123
430/20	259-265	463/12	116-123
430/42	265	463/20SPOT	123
430/42PF	260-265	463/30SPOT	123
430/62	252-254-256-265	463/6	114-123
		463/12	110-112-113-122-123

Codice Articolo	Pagina	Codice Articolo	Pagina
Article code	Page	Article code	Page
<b>CORTEN</b>		493/12	217-225
468/1LED	357-372	493/24	225
468/1PFLED	362-372	<b>BAMBOO</b>	
468/2LED	356-372	496/8	408-424
468/35/E	372	497/8	403-424
468/35PF/E	372	497/8+8	424
468/50/E	372	497/12	402-424
468/50PF/E	361-372	<b>ICE RAIN</b>	
468/72/E	360-372	507/3A	94-99
468/72PF/E	372	507/4L	98-99
468/120LED	358-372	507/6A	89-94-99
468/P	370-373	507/6P	96-97-95-99
469/1L	371-373	507/6S	99
469/3A	365-373	507/10	91-99
469/3AG	364-373	507/10PF	95-99
469/6	357-372	507/12	84-90-99
469/6PF	363-372	507/12PF	99
469/12	372	507/18	85-99
469/120	372	508/10	88-99
<b>CRYSTAL MOON</b>		508/12	86-87-99
475/1AG/PFG	275-281	508/80	92-93-99
475/1AP/PFP	275-281	508/120	99
475/1L	280-281	<b>CORTEN</b>	
475/1SG	277-281	509/3L	368-373
475/1SP	276-281	509/4	355-372
475/8	279-281	509/4A-G	366-373
475/12	272-273-281	509/4A-M	373
475/12PF	274-281	509/4L	368-373
<b>CRYSTAL ROCK</b>		509/6	354-372
476/2L	353	509/8	355-372
476/3	353	509/16A-G	373
476/3L	352-353	509/16A-M	367-373
476/4	346-347-348-349-353	509/350L	369-373
476/4A	351-353	509/500L	369-373
476/4PF	350-353	509/700L	369-373
<b>AMALFI</b>		<b>WEAVE</b>	
478/35/E	381	511/1L	138-141
478/35PF/E	381	511/2A	136-141
478/50/E	381	511/2L	141
478/50PF/E	381	511/3	131-140
478/72/E	381	511/3L	141
478/72PF/E	381	511/4	131-140
478/90/E	381	511/4L	137-141
478/90PF/E	381	511/6	130-140
482/35	381	<b>CRYSTAL BLADE</b>	
482/35PF	380-381	512/1A	239-251
482/50	374-375-376-381	512/1L	250-251
482/50PF	380-381	512/2A	246-251
482/72	377-379-381	512/2L	250-251
482/72PF	381	512/3A	244-245-251
482/90	378-381	512/5P	249-251
482/90PF	381	512/5SG	247-251
<b>WEAVE</b>		512/6	243-251
490/50	134-135-140	512/6+3	238-251
490/70	140	512/8	241-251
<b>CRYSTALLINE</b>		512/120	240-251
493/2A	222-225	<b>WEAVE</b>	
493/3L	224-225	513/3A	141
493/6	214-214-220-225	513/6	140
493/6P	223-225	513/6PF	141
493/10	219-225	513/8	125-140
493/10PF	221-225	513/8PF	132-141
493/16	225	513/12	124-140
493/16+16	218-225	513/26	126-127-140
493/80PF	225	514/6	129-140

Codice Articolo	Pagina
Article code	Page
<b>FLAME</b>	
524/1A	329-331
524/1L	330-331
524/1P	323-331
524/2A	328-331
524/3PF	327-331
524/5PF	327-331
524/6	324-331
524/6R	331
524/8R	325-331
524/10	322-331
525/1A	331
525/2A	331
525/6	320-331
525/6R	331
525/8R	331
525/10	331
<b>GRACE</b>	
530/2A	318-319
530/6	316-319
530/6+3	319
530/10+5	317-319
<b>PRESTIGE</b>	
532/1A	333-341-345
532/1L	335-345
532/1S	336-345
532/2A	345
532/6	332-345
532/6+3	337-345
532/6P	344-345
532/6PF	340-345
532/6+6	334-345
532/8R	345
532/80	345
534/1A	336-345
534/1L	345
534/1S	345
534/2A	338-345
534/6	339-342-345
534/6+3	345
534/6P	345
534/6PF	345
534/6+6	345
534/8R	343-345
534/80	345
<b>VANITY</b>	
584/1L	284-285
585/1L	282-283-285
<b>WEAVE</b>	
590/1L	139-141
591/1L	139-141
<b>ELITE</b>	
596/2+1	107-109
596/4+1	108-109
596/8+1	100-101-109
596/8+1PF	102-103-109
596/28+3	109
596/34+3	104-105-109
596/41+6	109
596/150	106-109

Codice Articolo	Pagina
Article code	Page
<b>CHARME</b>	
600/1LG	304-305-315
600/1LM	307-315
600/1LP	305-315
600/7P	312-315
600/9P	312-315
600/13P	313-315
601/1LG	310-315
601/1LM	308-309-311-315
<b>LEAVES</b>	
605/1S	181
605/5A	178-179-181
605/5PF	181
605/8	180-181
605/10	181
605/10PF	181
605/16	181
605/16PF	181
606/10	176-177-181
606/16	172-173-174-181
<b>STARDUST</b>	
608/2+2	389-393
608R/7+6	383-393
608SR/10+8	382-393
608/8+1SL	384-393
608/18+6	393
609/1A	392-393
609/3A	390-393
609/4	388-393
609/9	391-393
609/15	393
610/1A	392-393
610/3A	390-393
610/4	388-393
610/9	386-387-393
610/24	385-393
<b>DIAMANTE</b>	
628/50	227-231
628/70	228-229-230-231
628/90	226-231
<b>CESARE</b>	
632/50	194-195-197-199
632/76	194-195-197-198-199
632/110	194-195-197-199
<b>KIT DIMMER</b>	
638/DIM24	
<b>ARTIC</b>	
641/90	71-83
642/3ADX	82-83
642/3ASX	83
642/4	77-83
642/50	83
642/60PF	78-79-83
642/70	70-83
642/90	68-83
642/90PF	83
642/115	83
642/150	76-82
642/L	80-83
643/10	74-75-82
643/12	72-73-82

Codice Articolo	Pagina
Article code	Page
<b>AMALGAMA</b>	
644/10	184-193
644/14	182-193
645/9	185-193
646/12PF	191-193
646/15	188-189-193
647/4	193
647/4A	190-193
647/4L	192-193
647/5	186-187-193
<b>ACROPORA</b>	
650/1L	50
650/3	51
650/4A	46-50
650/5L	49-50
650/8PF	51
650/9	51
650/9PF	51
650/14	51
650/15P	48-50
650/20	40-43-47-51
650/28	45-51
650/60	51
<b>ANGEL</b>	
653/1AP	267-271
653/1LG	270-271
653/1LP	271
653/1SG	268-271

## CLASSI ENERGETICHE

## Energy classes

ATTACCO BULB TYPE	QUESTO DISPOSITIVO È COMPATIBILE CON LAMPADINE DI CLASSI ENERGETICHE: THIS LUMINAIRE IS COMPATIBLE WITH BULBS OF THE ENERGY CLASSES:	IL DISPOSITIVO È VENDUTO CON UNA LAMPADINA DI CLASSE ENERGITICA: THIS LUMINAIRE IS SOLD WITH BULBS OF THE ENERGY CLASSES:	COLLEZIONE COLLECTION
G9	DA <b>A++</b> AD <b>E</b> FROM <b>A++</b> TO <b>E</b>		BAMBOO, CHRYSALIS, CORTEN, CRYSTAL BLADE, CRYSTAL MOON, CRYSTAL ROCK, CRYSTALLINE, ELITE, FLAME, GROOVY, LEAVES, NINFEA, NUVOOLA, PARADISE, PRESTIGE, ROMA, WEAVE.
E27 / E14	DA <b>A++</b> AD <b>E</b> FROM <b>A++</b> TO <b>E</b>		AMALFI, BAMBOO, CHARME, CHRYSALIS, CORTEN, CRYSTAL MOON, FLAME, GRACE, GROOVY, PARADISE, ROMA, VANITY, WEAVE.
LED	DA <b>A++</b> AD <b>A</b> FROM <b>A++</b> TO <b>A</b>	Le lampade di questo dispositivo non sono sostituibili The lamps cannot be changed in the luminaire	ACROPORA, AMALFI, AMALGAMA, ANGEL, ARTIC, CESARE, CHRYSALIS, CORTEN, CRYSTAL MOON, CRYSTALLINE, DIAMANTE, DIVINA, ELITE, EKLE', FLORITUDE, FLOWER MIU, GROOVY, ICE RAIN, LEAVES, MIU, NINFEA, TRIBU-
GU10 LED	<b>A+</b>		BAMBOO, CHRYSALIS, DIVINA, GROOVY.
G4	<b>A++</b>		NINFEA.
G4 LED	DA <b>A++</b>		DIVINA, STARDUST.

**CE** La marcatura CE è la certificazione che definisce che tutti i prodotti IDL Export Srl sono verificati secondo le normative europee di sicurezza, in base alle norme seguenti:

The CE mark is the certification which defines that all products of IDL Export Srl are conforming the European security regulations, as per following rules:

CEI EN 60598-1	prescrizione generali e prove / general requirements and tests
CEI EN 60598-2-1	apparecchi di illuminazione fissi per uso generale / fixed lighting equipments for general use
CEI EN 60598-2-4	apparecchi di illuminazione mobili per uso generale / mobile lighting equipments for general use
CEI EN 60598-2-6	apparecchi di illuminazione con trasformatore incorporato per lampade ad incandescenza / lighting equipments with built-in transformer for incandescent lamps

IP20 Indica la resistenza offerta dall'apparecchio alla penetrazione di solidi e liquidi, denominata con il codice IP (International Protection) e seguita da due cifre, 2 che indica il grado di protezione contro l'ingresso di corpi solidi (protetto per corpi di dimensioni superiori a 12mm) e 0, che indica il grado di protezione contro l'ingresso di corpi liquidi (non protetto).

Indicates the resistance given by the lighting fitting to the penetration of solids and liquids, stated by the code IP (International Protection) and followed by two digits, 2 which means the rate of protection against the entry of solid parts (protected against entry of solid parts with dimensions more than 12mm), and 0, which indicates the rate of protection against the entry of liquid parts (not protected).

CLASSE I Apparecchi con parti metalliche costantemente collegate al circuito terra  
Equipments with metal parts constantly connected to the earth circuit.

CLASSE II Apparecchi provvisti di doppio isolamento o isolamento rinforzato e senza dispositivi di messa a terra  
Equipments provided with double insulation or reinforced insulation without earthing devices

CLASSE III Apparecchi alimentati con tensione di sicurezza inferiore ai 50V  
Equipments powered with safety voltage lower than 50V.

Apparecchi idonei a essere montati su superfici normalmente incombustibili  
Equipments suitable to be fitted on normally inflammable surfaces.

Prodotti assoggettati alla normativa RAEE/WEEE (2002/96/CE)  
Products according to the rules RAEE/WEEE (2002/96/CE)

Tutti i modelli sono depositati / All designs registered

CONDIZIONI GENERALI DI VENDITA DI AZIENDA S.P.A.  
valide ed applicabili dal 01/01/2017

**1. Premessa**

Le presenti Condizioni Generali di Vendita di IDL EXPORT SRL, con sede legale in Via San Marco n.2, 31050 Fanzolo di Vedelago (TV) Italia, C.F. e P. IVA 03247000262 (di seguito "AZIENDA") regolano tutte le vendite dei prodotti realizzati e/o commercializzati da AZIENDA stessa (di seguito "Prodotti") ai propri clienti (di seguito gli "Acquirenti"), se non espressamente derogate per iscritto. Le presenti Condizioni Generali di Vendita sostituiscono ogni altro impegno, contratto o intesa, scritta o verbale, intervenuta/a in precedenza fra AZIENDA e l'Acquirente. In nessun caso si intenderanno applicabili altre condizioni di qualsiasi natura apposte su ordini e/o altri documenti inviati dall'Acquirente o da terzi, salvo espressa accettazione scritta di AZIENDA.

**2. Conclusione del Contratto**

L'ordine trasmesso dall'Acquirente diverrà impegnativo solo se effettuato per iscritto, anche via fax o mezzo mail. Il contratto si intende perfezionato esclusivamente quando l'Acquirente abbia ricevuto la conferma d'ordine scritta di AZIENDA, ovvero nel momento in cui AZIENDA inizi a dare esecuzione all'ordine trasmesso dall'Acquirente. Qualora la conferma d'ordine trasmessa da AZIENDA all'Acquirente contenga modifiche rispetto all'ordine, le modifiche si considereranno tacitamente accettate trascorsi 5 (cinque) giorni lavorativi dal ricevimento della conferma d'ordine senza che l'Acquirente abbia manifestato il proprio dissenso per iscritto.

**3. Consegna e spedizione**

Ove non diversamente pattuito nel Contratto, i Prodotti sono consegnati EXW (Incoterms® 2010) presso la sede legale di AZIENDA sita in 31050 Fanzolo di Vedelago (TV) via San Marco n. 2 – ITALIA - (in seguito denominata "Consegna"). Salvo diverso accordo scritto, l'Acquirente dovrà ritirare i Prodotti entro e non oltre 8 (otto) giorni. In caso di ritardo nel ritiro dei Prodotti, i termini di pagamento concordati non subiranno alcuna proroga e l'Acquirente si farà carico di tutte le spese relative all'occupazione dei magazzini di AZIENDA ammontanti ad un importo fisso giornaliero pari allo 0,5% del prezzo netto dei Prodotti. Resta inteso che il rischio di danneggiamento, deperimento, perdita e/o furto degli stessi graverà sull'Acquirente a partire dalla data di Consegna inizialmente convenuta. L'azienda provvederà ad imballare i prodotti con un imballaggio standard per normali trasporti e movimentazioni. Qualora si rendessero necessari imballaggi particolari, questi ultimi verranno fatturati al costo secondo gli accordi intervenuti di volta in volta con l'Acquirente. In nessun caso i termini di consegna convenuti nel Contratto (di seguito "Termini di Consegna") assumono carattere di termine essenziale. Qualora sia previsto un anticipo all'ordine, l'apertura di una lettera di credito o il rilascio di una garanzia bancaria, i termini di consegna inizieranno a decorrere dal ricevimento dell'anticipo o dei documenti comprovanti l'operatività della lettera di credito o della garanzia. I termini di cui sopra restano, inoltre, sospesi fino alla comunicazione da parte dell'Acquirente di tutti i dati tecnici ed amministrativi necessari per la corretta evasione dell'ordine. I termini di consegna si intendono automaticamente prorogati in caso di modifiche alla fornitura richieste dall'Acquirente successivamente alla conclusione del contratto e si intendono automaticamente sospesi in caso di mancato pagamento da parte dell'Acquirente di qualsiasi importo dovuto a AZIENDA, anche se non relativo alla fornitura in oggetto. Eventuali ritardi nella Consegna inferiori o uguali a 30 (trenta) giorni rispetto al Termine di Consegna convenuto o prorogato non possono in alcun caso dar luogo a pretese di risarcimento danni o di riduzione del prezzo, né ad annullamento e/o risoluzione e/o modifica del Contratto. In caso di ritardo nella Consegna superiore di 60 (sessanta) giorni, l'Acquirente avrà diritto a una penale giornaliera pari a EUR 50,00 (cinquanta/00), a decorrere dal sessantesimo giorno e fino alla data di consegna effettiva; l'Acquirente rinuncia espressamente a richiedere il maggior danno, a pretese di riduzione del prezzo, a richiedere l'annullamento e/o la risoluzione e/o la modifica del Contratto. In caso di ritardi nella Consegna dei Prodotti determinati da caso fortuito, forza maggiore, ritardi o mancate consegne dei propri fornitori e/o altre cause non imputabili a dolo e/o colpa grave o comunque qualsiasi altra causa al di fuori del ragionevole controllo di AZIENDA, l'Acquirente non avrà titolo per richiedere alcun indennizzo e/o risarcimento del danno, né per richiedere la risoluzione e/o la modificazione e/o l'annullamento del Contratto o la riduzione del prezzo dei Prodotti forniti.

**4. Prezzi e termini di pagamento**

Salvo diversa indicazione contenuta nella conferma d'ordine, i prezzi dei Prodotti sono quelli risultanti dal listino prezzi di AZIENDA in vigore al momento della conferma ed espressi in Euro. Il pagamento dovrà essere effettuato secondo le modalità di pagamento indicate da AZIENDA nella conferma d'ordine. In ogni caso, il Venditore si riserva il diritto di aumentare il prezzo pattuito prima della consegna, al fine di coprire i maggiori costi dei Beni dovuti a cause estranee alla volontà del Venditore. I Prodotti rimangono di proprietà di AZIENDA sino ad integrale pagamento del prezzo o ad integrale incasso di eventuali assegni, cambiali, o mezzi di pagamento negoziabili, anche se i documenti di trasporto sono stati già consegnati. In caso di mancato pagamento, anche parziale, del prezzo, AZIENDA avrà facoltà di sospendere l'esecuzione del Contratto sino all'integrale pagamento delle somme dovute, o alla prestazione di idonee garanzie. In caso di ritardo nel pagamento, anche parziale, AZIENDA avrà diritto al pagamento degli interessi di mora previsti dalla legge applicabile (D.Lgs. n. 231/2002 e successive modifiche), che in ogni caso cominceranno a decorrere automaticamente dal di della debenza senza alcuna necessità di formale costituzione in mora. In nessun caso, eventuali vizi dei Prodotti, quand'anche espressamente

racconosciuti da AZIENDA, nonché eventuali ritardi rispetto ai Termini di Consegna, conferiranno all'Acquirente la facoltà di sospendere i relativi pagamenti, e/o qualsiasi altro pagamento dovuto a AZIENDA in forza del presente Contratto o di altri rapporti contrattuali.

**5. Garanzie e reclami – Resi – Listino/I**

AZIENDA garantisce l'assenza di vizi nei Prodotti ai sensi di legge. Qualora gli eventuali reclami dell'Acquirente in ordine alla presenza di vizi nei Prodotti risultino fondati e accettati da AZIENDA nel periodo di garanzia, AZIENDA provvederà gratuitamente alla sostituzione dei Prodotti viziati e/o, a propria insindacabile discrezione, alla riparazione degli stessi con consegna effettuata EXW (Incoterms® 2010) presso la sede legale di AZIENDA. Resta inteso che l'obbligo di garanzia assunto da AZIENDA si intende limitato ai soli vizi dei Prodotti espressamente riconosciuti ed accettati da AZIENDA. Al momento del ricevimento l'Acquirente dovrà esaminare immediatamente i singoli Prodotti. A pena di decadenza dalla garanzia, l'Acquirente dovrà denunciare i vizi riscontrati nei Prodotti per iscritto. La presente garanzia all'Acquirente copre unicamente i difetti di materiale o lavorazione dei Prodotti ed in normali condizioni di utilizzo, trasporto, stoccaggio, conservazione, esposizione e vendita. Inoltre la presente garanzia sarà operativa soltanto a condizione che: 1) l'Acquirente non sia in ritardo con alcun pagamento, neppure per forniture diverse da quella relativa ai Prodotti difettosi; 2) i Prodotti siano utilizzati nell'ambito di un uso consentito per le loro caratteristiche tecniche e nel rispetto ed entro i limiti indicati nelle istruzioni per l'installazione; 3) i Prodotti siano installati da tecnici qualificati nel rispetto delle istruzioni per l'installazione fornite e delle normative tecniche; 4) i Prodotti siano alimentati con dispositivi di alimentazione forniti da AZIENDA e, ove previsto, installati nelle cassette fornite dall'installatore in conformità alle norme vigenti; 6) i prodotti siano stati modificati, manomessi o riparati da parte di terzi che non hanno ricevuto l'autorizzazione preventiva da AZIENDA; 7) i vizi del prodotto siano dovuti a eventi imprevedibili o non ragionevolmente probabili, comprese scariche elettriche, fulmini o correnti elettrostatiche; 8) l'impianto elettrico operi in un ambiente le cui caratteristiche non sono conformi a quelle necessarie per un corretto funzionamento in base alla tipologia e destinazione del Prodotto, tra cui, a titolo di esempio, disturbi di linea impulsivi, sbalzi di tensione, eccessiva temperatura o aereazione insufficiente. In particolare e senza limitazione per la generalità di quanto precede, la garanzia non si estende ai Prodotti usati o di seconda mano, ai difetti dei Prodotti causati da inadeguate modalità di stoccaggio, trasporto, conservazione, manutenzione, esposizione o vendita adottate dall'Acquirente (o da terzi) ovvero ai difetti del Prodotto imputabili a colpa dell'Acquirente (o di terzi) o al mancato rispetto delle istruzioni ed indicazioni d'uso fornite da AZIENDA.

L'Acquirente dichiara e riconosce che le informazioni e/o i dati e/o le immagini e/o le diciture dei Prodotti, indicati negli elenchi di AZIENDA e/o nel sito web [www.AZIENDA.it](http://www.AZIENDA.it) e/o in altro materiale di natura tecnica e/o commerciale e/o promozionale, hanno natura meramente indicativa. AZIENDA si riserva espressamente il diritto di modificare, in qualsiasi tempo e senza preavviso, le specifiche, i modelli, i materiali, i colori, gli accessori, le finiture e in generale qualsivoglia caratteristica dei Prodotti indicati negli elenchi e/o nei suddetti siti Internet e/o in altro materiale di natura tecnica e/o commerciale e/o promozionale. Eventuali restituzioni dei Prodotti dovranno essere sempre preventivamente autorizzate per iscritto da AZIENDA. L'Acquirente sarà quindi tenuto a dare preavviso scritto a AZIENDA della spedizione dei Prodotti in restituzione, che dovrà essere tassativamente effettuata DDP (Incoterms 2010) sede di AZIENDA.

**6. Oneri**  
Eventuali tasse, imposte, dazi, tributi, licenze, autorizzazioni, permessi e/o altri oneri di natura fiscale e/o doganale e/o amministrativa comunque denominati, previsti dalla normativa dello Stato di importazione dei Prodotti oggetto del Contratto (d'ora in poi, "Oneri"), sono interamente ed esclusivamente a cura e a carico dell'Acquirente. In nessun caso, eventuali ritardi nell'assolvimento degli Oneri conferiranno all'Acquirente titolo per risolvere il Contratto e/o per richiedere il risarcimento danni. L'Acquirente rinuncia espressamente a sollevare qualsiasi contestazione, pretesa, eccezione e/o domanda riconvenzionale a tal proposito.

**7. Lingua**

Le presenti condizioni generali di vendita sono redatte in lingua italiana, da intendersi come unico testo fidede. Ogni traduzione delle Condizioni Generali di Vendita o ogni altro documento contrattuale formulato in lingua diversa da quella italiana è da intendersi per i soli motivi di cortesia.

**8. Foro esclusivamente competente – Rimborso delle spese legali**

Per qualsiasi controversia che dovesse insorgere relativamente alla conclusione, applicazione, interpretazione, validità, efficacia, esecuzione e/o risoluzione del Contratto sarà competente in via esclusiva il Tribunale di Treviso (Italia). E' comunque fatta salva la facoltà di AZIENDA di agire in giudizio, anche in via cautelare o provvisoria, avanti al foro del domicilio dell'Acquirente. Per qualsiasi controversia che dovesse insorgere relativamente alla conclusione, applicazione, interpretazione, validità, efficacia, esecuzione e/o risoluzione del Contratto, la parte vittoriosa avrà il diritto di ottenere dalla controparte il rimborso di qualsivoglia costo, spesa e compenso professionale tecnico e/o forense, di misura ragionevole, sostenuto in relazione alla controversia.

**9. Legge applicabile**

La legge applicabile al Contratto è quella italiana, intendendosi in ogni caso espressamente esclusa l'applicazione al Contratto della Convenzione di Vienna del 11 aprile 1980 sui contratti di vendita internazionale di merci (ad eccezione di quanto previsto all'articolo 11 della Convenzione in merito alla libertà di forma dei contratti, che trova applicazione).

GENERAL CONDITIONS OF SALE OF AZIENDA S.P.A.  
Valid and enforceable starting from 01/01/2017

**1. Premise**

The following General Conditions of Sale of IDL EXPORT SRL, with registered office in Via San Marco n.2 31050 Fanzolo di Vedelago (TV) in Italy, CF – P IVA 03247000262, (hereinafter called "AZIENDA ") shall govern all sales of products made by AZIENDA (hereinafter "Products") to its clients (hereinafter the "Purchaser"), if not expressly derogated in writing. The General Conditions of Sales supersedes any written or verbal commitment, agreement or covenant previously established between AZIENDA and Purchaser. In no event other conditions of any kind affixed to orders and/or other documents sent by the Purchaser or third parties shall apply without the express written approval of AZIENDA.

**2. Entering into the Agreement**

Any order placed by the Purchaser will be binding only if made in writing, also by fax or mail. The sale contract shall, therefore, become final and binding only upon receipt by the Purchaser of AZIENDA's written order confirmation, or when AZIENDA commences execution of the order submitted by the Purchaser. Should the order confirmation sent by AZIENDA to the Purchaser contain any modifications with respect to the order, such modifications shall be deemed to have been tacitly accepted by the Purchaser after a 5 (five) working day term of receipt by the latter of such order confirmation, unless the Purchaser gives written notice of disagreement to AZIENDA.

**3. Delivery Terms**

Unless otherwise agreed in the Agreement, the Products are delivered EXW (Incoterms 2010) to the registered office of AZIENDA in 31050 Fanzolo di Vedelago (TV) Via San Marco n. 2 in Italy (hereinafter referred to as "Delivery"). Unless otherwise agreed in writing, the Purchaser shall collect the products no later than 8 (eight) days. In case of delay in the withdrawal of the Products, the agreed payment terms shall not be extended and the Purchaser shall pay all charges relating to the occupation of the warehouses to AZIENDA amounting to a daily fixed sum of 0,5% of the Products' net price. It is understood that the risk of damage, deterioration, loss and/or theft of the same will be borne by the Purchaser from the initially agreed date of delivery. The Company shall provide the Products with standard packaging suitable for ordinary transportation and handling. Should a special packaging be required, the latter shall be invoiced at cost according to the agreements entered into on a time to time basis with the Purchaser. In no event the delivery terms agreed in the Agreement (hereinafter "Terms of Delivery") shall be considered final terms. Should an advance payment on the order, the opening of a letter of credit or the issuance of a bank guarantee be agreed, delivery terms will start running as of receipt of such advance payment or of the documents confirming the effectiveness of the letter of credit or the bank guarantee. The abovementioned terms shall be suspended until notification by the Purchaser of all technical and administrative data and information necessary for the proper fulfillment of the order. Terms of delivery shall be automatically extended in case the Purchaser request any modification to the order after the sale contract being finalised and shall be automatically suspended in case the Purchaser fail to pay any amount due to AZIENDA even if such failure is not related to the pending order. Any delays in delivery of 30 (thirty) days or less from the agreed or extended delivery term cannot under any circumstances give rise to claims for damages or price reductions, or entitle to cancelling and/or terminating and/or amending the Agreement. In case of late delivery exceeding sixty (60) days, the Purchaser shall be entitled to a daily penalty of EUR 50.00 (fifty/00), effective from the sixty-first day until the actual delivery date; the Purchaser gives up expressly claims for the maximum damage, to claims of reduced prices, to request cancellation and/or termination and/or amendment of the Agreement. In case of delays in delivery of certain products caused by unforeseeable circumstances, force majeure, to delay or lack in deliveries by its suppliers and/or other causes not attributable to willful misconduct and/or gross negligence or any other cause beyond the reasonable control of AZIENDA, the Purchaser shall not be entitled to claim any compensation and/or damages, nor to require the termination and/or amendment and/or cancellation of the agreement or the price reduction for the furnished products.

**4. Price and payment terms**  
Unless otherwise indicated in the order confirmation, prices of the Products expressed in Euro shall be those set forth in AZIENDA's price list in force at the date of the order confirmation. Payment shall be performed according to the terms indicated by AZIENDA in the order confirmation. However, the Seller shall have the right to increase the price of the Goods at any time before the delivery, in order to cover increases in the cost of the Goods due to any factor beyond the control of the Seller. Products shall remain the sole property of AZIENDA until full payment of the price or full cash of any possible checks, promissory notes, or any other negotiable means of payment have occurred, even if the transport documents have already been delivered. In case of failure to pay even partially the price, AZIENDA shall be entitled to suspend the execution of the Agreement until full payment of the due amounts, or the enforcement of appropriate guarantees. In case of late payment, even partial, AZIENDA will be entitled to the payment of default interests permitted by applicable law (Legislative Decree no. 231/2002, as amended), which in any case will begin to accrue automatically from the due day without need of any default notice.

**5. Exclusive jurisdiction - Reimbursement of legal fees**  
For any dispute that may arise related to the conclusion, application, interpretation, validity, effectiveness, execution and/or termination of this Agreement will be referred exclusively to the Court of Treviso (Italy). Still AZIENDA has the right to act in justice, as an interim or provisional measure, before the competent court of law of the Purchaser's address.

For any dispute that may arise related to the conclusion, application, interpretation, validity, effectiveness, execution and/or termination of this Agreement, the winning party shall be entitled to obtain from the other party the reimbursement of any professional technical and/or forensic costs, expenses and compensation, to a reasonable extent, incurred in relation to the dispute.

**6. Applicable Law**  
The law applicable to the Agreement is Italian, being expressly excluded the application to the Agreement of the Vienna Convention of April 11, 1980 on the International Sale of Goods being hereby expressly excluded (with the exception of art. 11 thereof regarding the agreements' freedom of forms, which shall apply).

Under no circumstances, any defects of the products, even if expressly recognized by AZIENDA, as well as any delays in meeting the delivery terms, will give the Purchaser the right to suspend the payments, and/or any other payment due to AZIENDA under this Agreement or other contractual relationships (estoppel clause pursuant to art. 1462 cc).  
**5. Guarantees and claims – returned goods – list-i**  
AZIENDA guarantees the absence of defects in products pursuant to the law. In the event that any complaint of the Purchaser with regard to defects in products proves to be justified and accepted by AZIENDA during the warranty period, AZIENDA will provide free replacement of faulty products and/or, at its sole discretion, their repair with delivery made EXW (Incoterms 2010) at the registered office of AZIENDA. It is understood that the guarantee obligation assumed by AZIENDA is limited to Product defects expressly recognized and accepted by AZIENDA. The Purchaser shall examine each single Product immediately upon receipt. Under penalty of cancellation of the guarantee, the Purchaser must report the defects found in the products in writing. This warranty for the Purchaser only covers defects in material or workmanship of the Products, and applies under normal conditions of usage, transport, storage, maintenance, display and sale. Furthermore, this warranty shall apply only on condition that: 1) the Purchaser is not late in any payment either or not related to the defective Products; 2) the use of the Products is consistent with their technical characteristics and is in compliance and within the limits set forth under the installation instructions; 3) the Products are installed by qualified technicians in compliance with the installation instructions and the technical regulations; 4) the Products are powered with power devices supplied by AZIENDA and, if necessary, installed in the AZIENDA's shuttering; 5) the installation of the Product is certified by the installer in accordance with applicable regulations; 6) the Products have been modified, altered or repaired by third parties not previously authorised by AZIENDA; 7) the defects of the Product are due to unexpected or not reasonably probable events, including electric shocks, lightning or electrostatic discharges; 8) the electrical system is operating in an environment whose characteristics are not compliant with those required for a proper functioning according to the type and destination of the Products, including, by way of example, impulsive line noise, sudden power surges, excessive temperature or insufficient ventilation. In particular, and without prejudice of the generality of the foregoing, the warranty shall not apply to used or second-hand Products, in case of defects of Products caused by inappropriate conditions of storage, transport, custody, maintenance, display or sale by the Purchaser (and/or by third parties) or defects of the Products due to fault of the Purchaser (or of third parties), or failure to comply with the instructions and indications for use provided for by AZIENDA. Purchaser understands and agrees that the information and/or data and/or images and/or terms of products, indicated in the lists of AZIENDA and/or on the website [www.AZIENDA.it](http://www.AZIENDA.it) and/or other materials for technical and/or commercial and/or promotional, are purely indicative. AZIENDA expressly reserves the right to change, at any time and without notice, specifications, models, materials, colors, accessories, finishes and in general any characteristic of the products reported in the list / s and/or these websites and/or other materials for technical and/or commercial and/or promotional.

**7. Language**

The present general conditions of sale are written in Italian and shall be understood as the only authentic text. Any translation of these General Conditions of Sale as well as any other contractual documents in any language other than Italian shall be deemed for courtesy purposes only.

The law applicable to the Agreement is Italian, being expressly excluded the application to the Agreement of the Vienna Convention of April 11, 1980 on the International Sale of Goods being hereby expressly excluded (with the exception of art. 11 thereof regarding the agreements' freedom of forms, which shall apply).

Nella tutela del cliente, IDL EXPORT SRL si riserva il diritto di apportare modifiche e/o migliorie ai prodotti illustrati nel presente catalogo senza alcun obbligo di preavviso. Ogni nostro prodotto viene etichettato secondo le normative vigenti e in esso viene applicato il tagliando di autenticità Made in Italy. Qualsiasi lieve variazione di tonalità imperfezione nei vetri non costituiscono un difetto, ma contribuiscono ad esaltarne la complessa lavorazione artigianale. For our customer protection, IDL EXPORT SRL reserves the right to modify and / or improve to the products shown in this catalogue without notice. Each product is labeled according to the regulations and it is applied authenticity coupon Made in Italy. Any slight variation in color and imperfections in the glasses is not a defect but a contribution to enhance the complex craftsmanship.

TUTELA SUI DIRITTI D'AUTORE, LEGGE 22/4/1941 N°633, LEGGE 14/12/1942 N°1485 PROIBITA OGNI RIPRODUZIONE ANCHE PARZIALE  
SAFEGUARDED BY THE LAW ON COPYRIGHT

**IDL EXPORT** s.r.l.  
via S. Marco, 14  
31050 Fanzolo di Vedelago (TV) Italy  
T 0039 0423 487141  
F 0039 0423 476206  
info@idlexport.it  
www.idl1987.it

IDL si riserva il diritto di apportare modifiche e/o migliorare i prodotti illustrati nel presente catalogo senza alcun obbligo di preavviso. IDL reserves the right to make changes and/or improvements to the products described in this catalog without prior notice. Tutela sui diritti d'autore, legge 22/4/1941 n°633, legge 14/12/1942 n°1485. Proibita ogni riproduzione anche parziale. Safeguarded by the law on copyright.



**IDL EXPORT** S.r.l.  
Concept and direction: **IDL EXPORT**  
Bank image: [iStockphoto.com](#), [unplash.com](#), [pexels.com](#)  
Photo: **EMANUELE SURIAN** Photographer / **FISHEYE** Massino Pesce / Quasar - [quasarfoto.com](#) - Studio Visus /  
Finished printing: February 2022

E' vietata la riproduzione anche parziale di questo catalogo.  
It is forbidden to reproduce any part of this catalogue.



