

LEE BROOM

2023



2023

BIOGRAPHY
2

LIGHTING
4

FURNITURE
100

ACCESSORIES
132

PRODUCT DETAILS
148



Lee Broom is one of the UK's leading product designers and a premium global design brand. With his highly original brand of luxury furniture and lighting designs, his work is recognised and retailed across the globe. Since founding the company in 2007, he has created over 100 furniture, accessory and lighting pieces, all of which are designed, manufactured and retailed under the Lee Broom brand. He has also collaborated with many other leading global brands including Christian Louboutin, Mulberry, Bergdorf Goodman and Wedgwood.

Lee Broom's designs can be seen in hotels, restaurants and homes across the world as well as on magazine covers and in newspapers internationally. His designs are both unique yet familiar as he takes classic styles and reinterprets them in new and contemporary ways with an unexpected edge.

Taking inspiration from his background in fashion design, he strives to embrace and explore new themes while keeping an overarching house style. Using the highest quality materials, combined with the latest technology, Lee Broom constantly evolves and innovates, resulting in his signature mix of classicism and modernity.

Having started out in theatre school, a beginning which has greatly influenced the sense of drama and narrative that his collections create, his career took a change of direction after he won a fashion design competition at the age of 17. This led him to meet and then go on to work for the legendary designer Vivienne Westwood, after which he studied for a degree in fashion design at Central St Martins. Fashion is still a great source of inspiration and The Guardian commented, "Lee Broom is to furniture what Marc Jacobs or Tom Ford are to fashion."

Lee Broom has won over 30 awards to date including the prestigious British Designer of the Year Award and The Queen's Award for Enterprise presented by Her Majesty The Queen at Buckingham Palace.

Presenting his collections each year in Milan, New York and London Design Weeks, he has gained a reputation for creating conceptual dynamic installations which are surreal, experiential and always unexpected.

Making design a successful global business Lee Broom's products are retailed in over 250 stores in 50 countries around the world alongside his own flagship showrooms in London and New York.



LIGHTING

VESPER

Vesper is inspired by the simple geometric lines of Brutalist sculpture and modernist cathedral lighting. Formed with extruded aluminium and available in anodized gold or silver, Vesper explores the delicate balance and interconnection of its rectangular cubes that are seamlessly connected by illuminated spheres. The light sculpture, which is suspended by cables, is available in both Duo and Quattro versions.







HAIL

Hail is inspired by the shards of light and shadow often experienced from lancet windows in vast church arches. Available in three standard sizes in a gold or silver brushed finish, Hail has an elongated fluted form fabricated in aluminium with asymmetrically positioned reeded glass lightbulbs placed along its structure. The lights can also be connected to create unique customisable configurations.



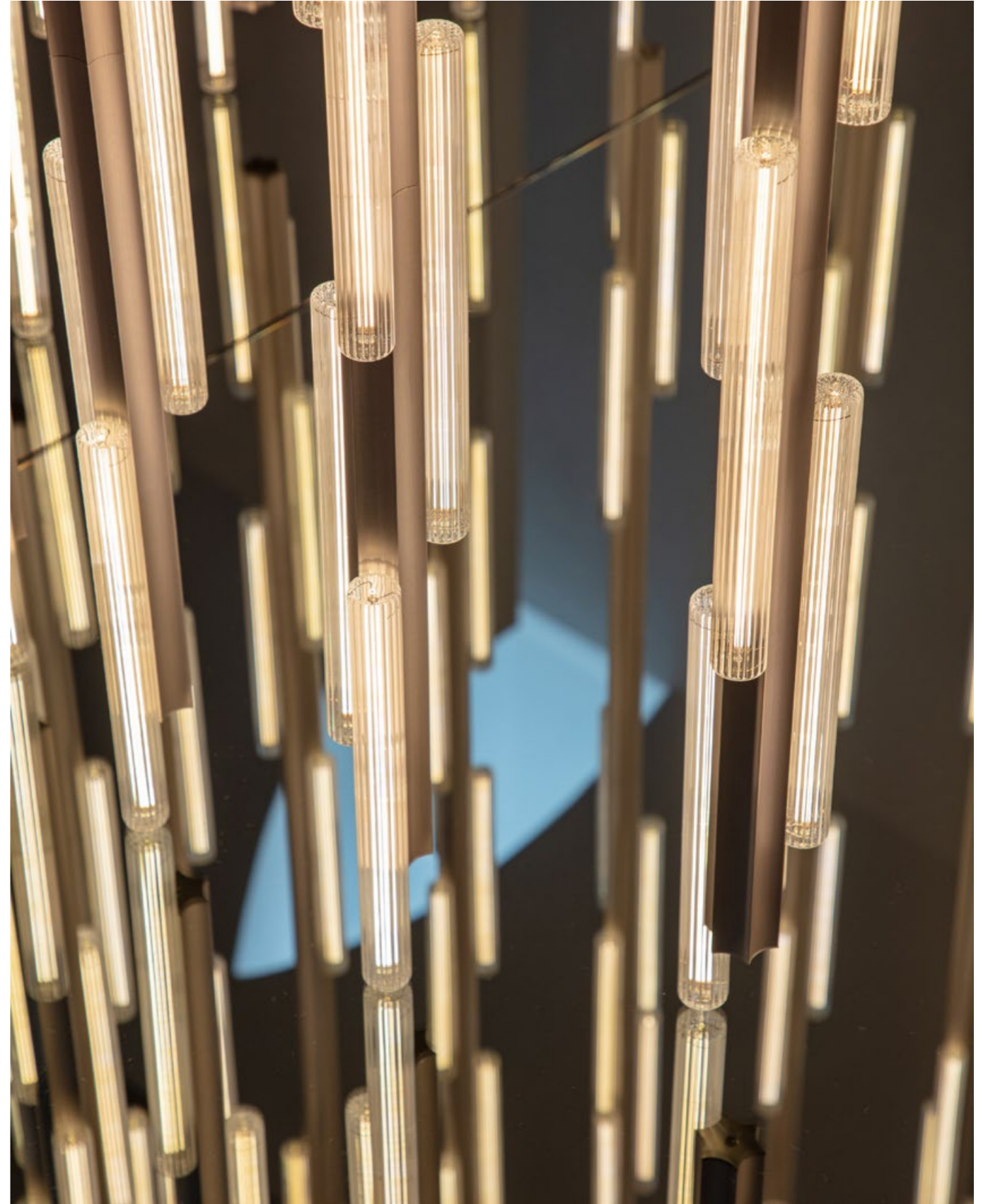

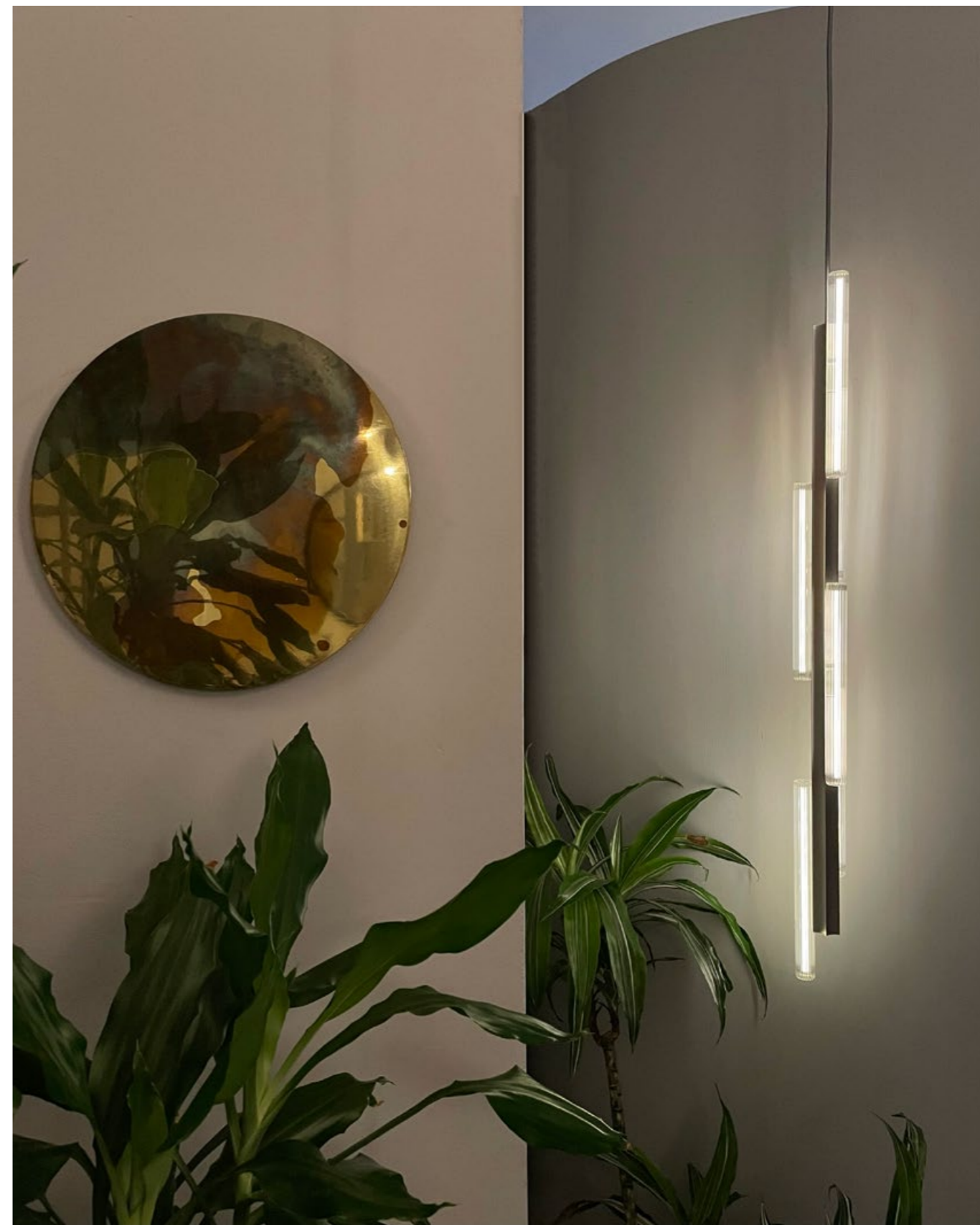

ALTAR

Altar is an exploration into the angular forms of Midcentury churches and altars, which often looked to warmer natural materials for fonts and pews. Altar's elegant, fluted form is carved from solid oak and completed with an illuminated tube seamlessly nestled in its architectural grooves. The light available in two sizes, can be suspended from a cable or surface mounted to the ceiling.



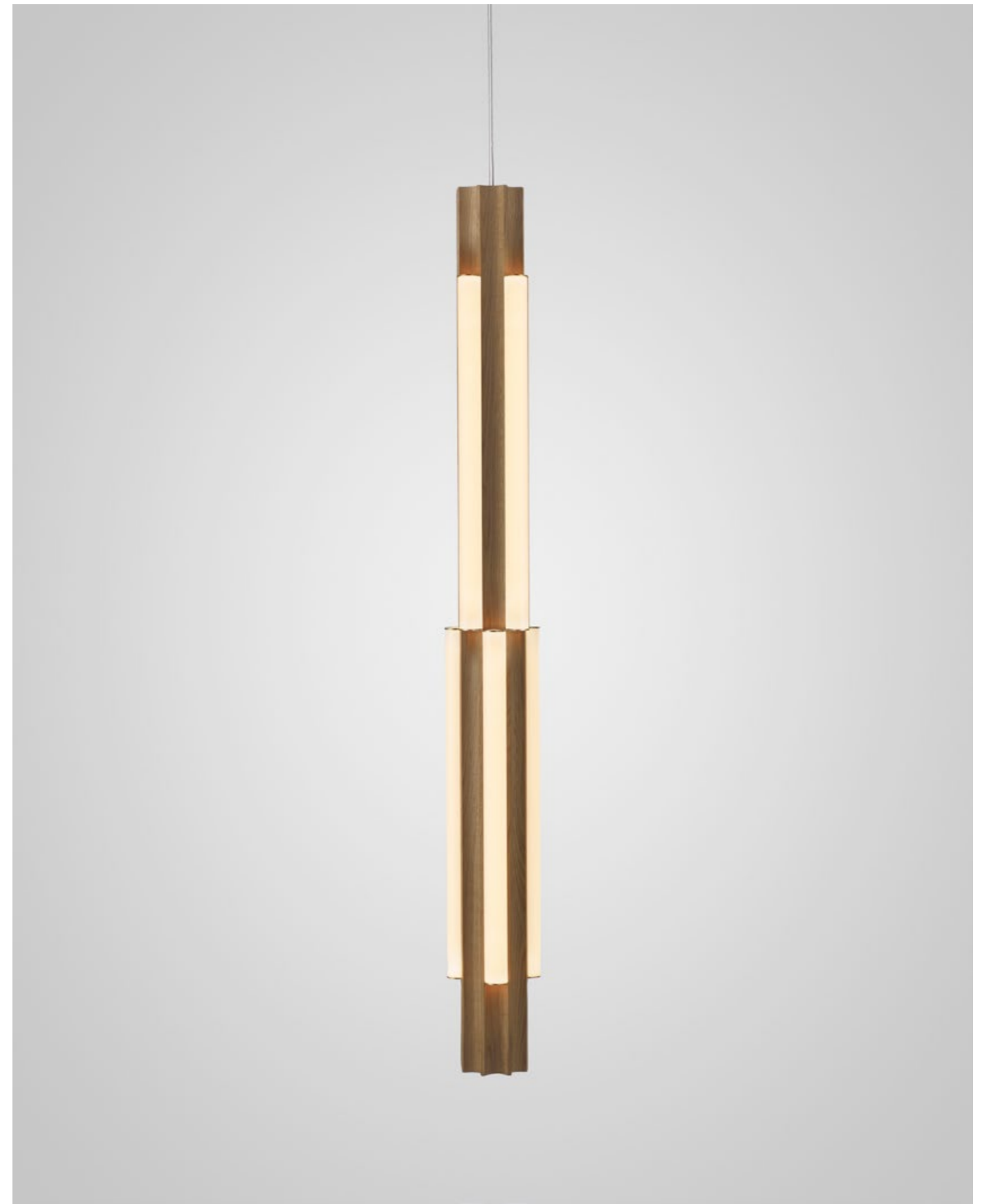

PANTHEUM

Pantheum is inspired by the distinctive concrete ceiling of Rome's ancient temple, The Pantheon, as well as the clean lines and geometry of Brutalist architecture. Cast by hand in Jesmonite, its silhouette is a stepped tile-like square that is then sand blasted to give its rough sandstone hewn surface. Pantheum is a surface light, each can be hung on its own or composed in symmetrical clusters to create a ceiling or wall constellation.





REQUIEM

Requiem is an ethereal series of limited-edition pieces. Each sculpted by hand, by Lee Broom in our London factory. The collection takes inspiration from the marble drapery on ancient statues and sepulchral sculptures. Each piece appears weightless and fluid but is solid in form, made by hand-draping fabrics in plaster through and around illuminated glass. These ghostly forms are then sculpted with more plaster into their final shape and set until solid. The effect is one of fragile drapery that appears to capture a floating light source. To celebrate the 15-year anniversary of Lee Broom, each of the four limited edition Requiem designs is limited to 15 pieces.





CHANT

Inspired by the pressed glass bricks often used as an alternative to stained glass in places of worship during the 1970s, Chant is formed of blown glass cubes with a pronounced circular detail in either clear or frosted glass. Constructed in square configurations, the glass cubes connect to form glowing brick-like chandeliers in single or two tiers.



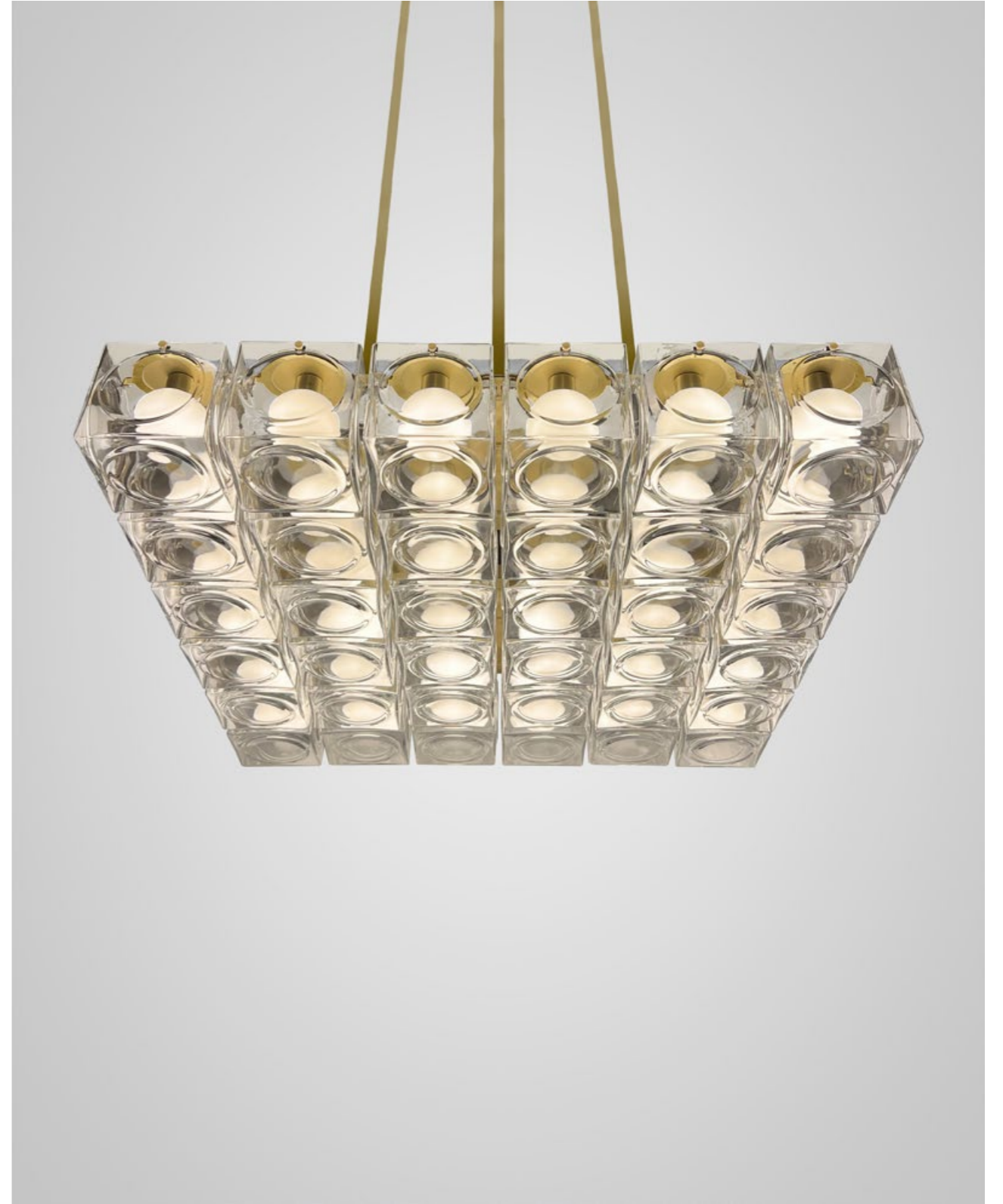

AURORA

A chandelier of multiple adaptations which projects layers of ethereal rings of light created from linear LED light bulbs. Created and produced by Lee Broom, the hand blown glass bulbs contain a perpendicular LED filament which refracts against the vertical lines of the reeded glass. En masse and reflecting in the mirror-polished stainless steel rings, the overall effect ensues a glowing aura.

Aurora is a scalable chandelier in which rings ranging from a 32cm to a 109cm diameter can be installed individually or connected together to create a tailored chandelier.



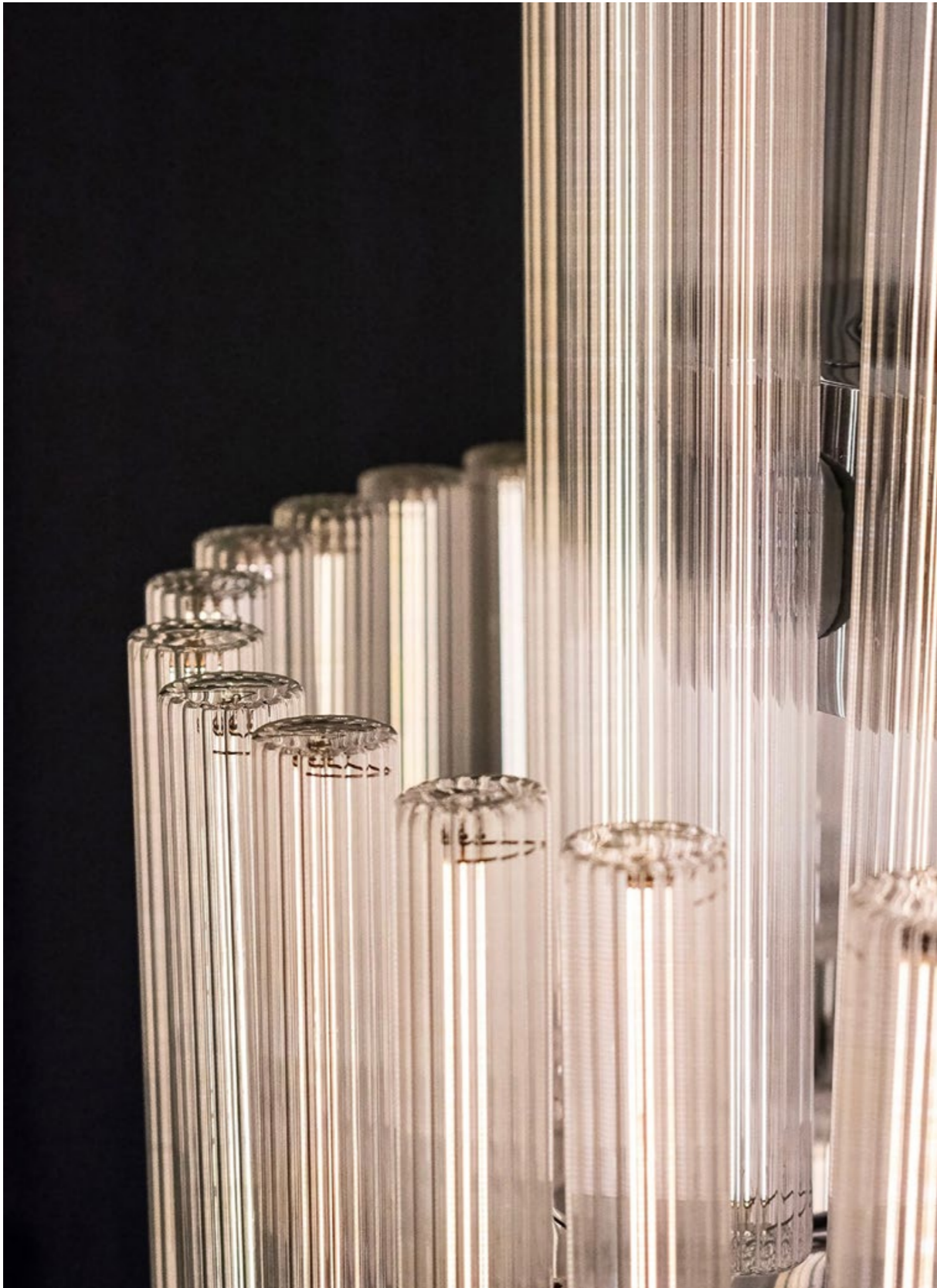





ECLIPSE

Eclipse is a lighting collection in both its name and inspiration. Mirror-polished stainless steel and acrylic discs interact, dissect and obscure, which both eclipses and reveals its illumination to the viewer at the same time. Available as a single pendant light, chandelier and table lamp, Eclipse has a sculptural silhouette with a mobile-like quality that changes at every angle. Finished in polished chrome or polished gold, Eclipse acts as a mirror, reflecting and refracting light and featuring LED lighting systems custom-designed and developed by Lee Broom. Using the refractive properties of an etched 10mm solid acrylic core and concealed LED technology to create a diffused halo, the design highlights Lee Broom's technical craftsmanship and innovation.





ORION

Orion comprises modular lights with opposing opaque and solid polished gold or gunmetal spheres along with opaque and solid polished gold or gunmetal tubes. Individually, these can be hung horizontally or vertically and when used in multiples create bespoke constellations of light with infinite adaptations. The lights are technically innovative with concealed LEDs that create a warm glow reflecting against the polished globes and tubes. The celestial-inspired collection has been designed around sculptural and spherical forms, which are both conceptual yet elegant.







LENS FLAIR

Inspired by telescopic lenses and the technique of horizontal and vertical refractions, Lens Flair is a product comprising two halves, seamlessly combining the solid and the transparent. A detailed cross-cut lens emits a soft deflected light, which is juxtaposed by a contemporary solid casing in brushed brass or matte black finishes. This striking new piece is available as a Pendant Light and Table Lamp. Lens Flair makes a bold statement by itself, or multiple pendants can be hung to create a more impactful installation.



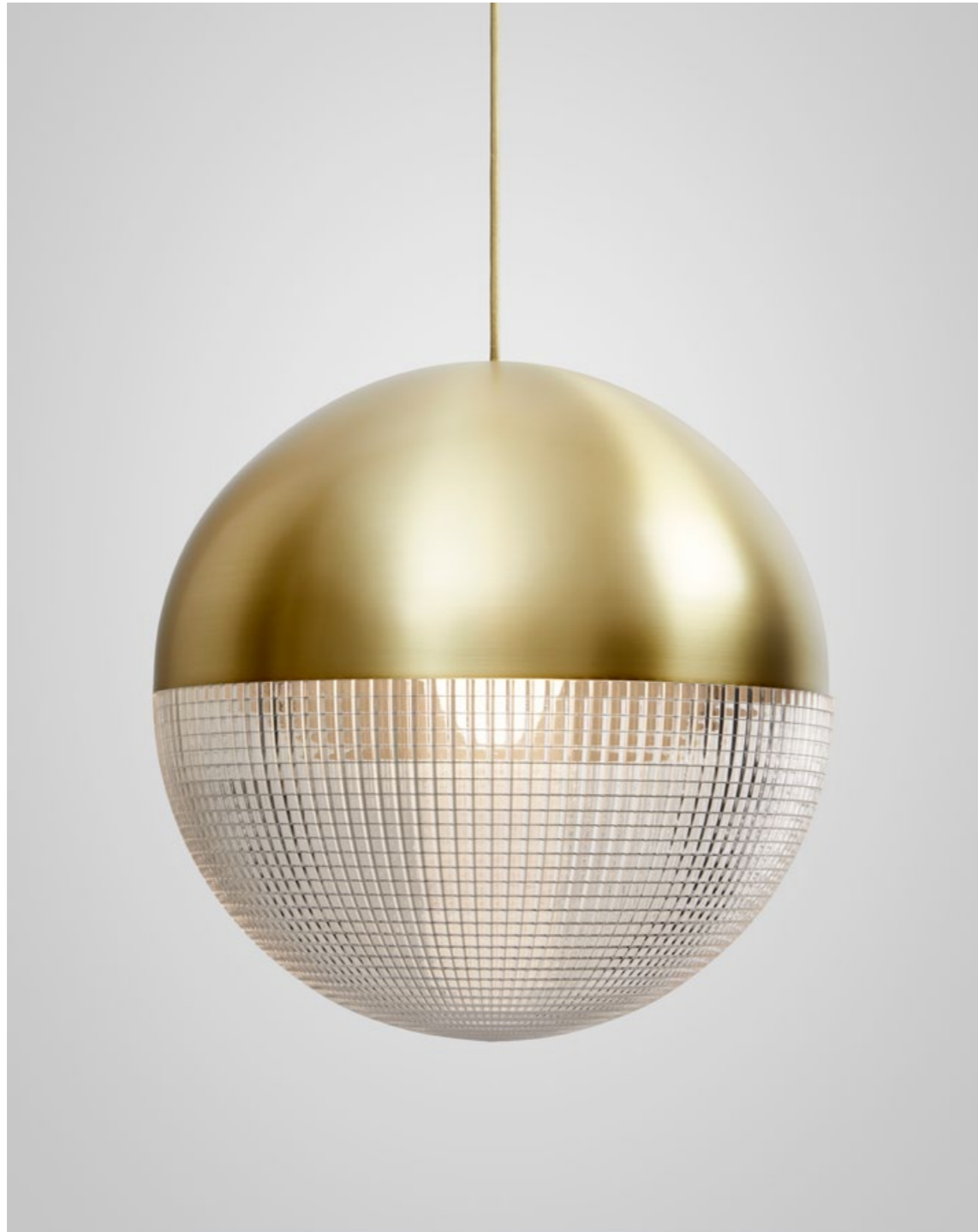

LITTLE LENS FLAIR

At 20cm (7 7/8 in), Little Lens Flair is a scaled-down new adaptation of the popular Lens Flair collection. Inspired by telescopic lenses and the art of horizontal and vertical refractions, Little Lens Flair is a piece of two halves, seamlessly combining the solid and the transparent. A detailed cross-cut lens emits a soft deflected light, which is juxtaposed by contemporary solid casing in brushed brass or matte black finishes. The beautiful adaptable piece is available as a Pendant Light, Table Lamp and Chandelier.





CRESCENT

A new twist on the classic globe light, Crescent Light is an illuminated sphere sliced asymmetrically in half to reveal a crescent-shaped brushed brass fascia. At 40cm / 15 ¾ inch diameter and containing a high power LED bulb, Crescent Light has presence and luminosity, seamlessly combining the solid and the opaque. Also available is the Crescent Table Lamp, nestling the sliced sphere on a ring of brushed brass.





MINI CRESCENT

A miniature version of the Crescent Light, Mini Crescent is a 20cm / 7 7/8" in sphere sliced asymmetrically in half to reveal a crescent-shaped brushed brass fascia. Further options available include Mini Crescent Chandeliers, composed of three or five pendants hung from a brushed brass canopy and the Mini Crescent Ceiling Light, which allows the shade to be mounted directly on the ceiling. Completing the family is the Mini Crescent Table Lamp.





FULCRUM LIGHT

Designed from the exploration of pivots and supports, Fulcrum Light is a slimline and elegant pendant of polished gold, polished chrome or matte black cylinders suspended around a central sphere. The exposed light bulb symmetrically mimics the silhouette of the sphere. The Fulcrum is also available as a three piece chandelier and five piece chandelier with matching finish canopy.





CAROUSEL

Inspired by the merry-go-round ride of a traditional fairground, Carousel is a pendant light with a heavyweight presence that floats gently in space. Cylinders of polished gunmetal, polished gold, polished chrome or matte black, each house an inset LED lighting element resulting in a spectacular yet playful ring of light. Carousel is 60cm / 23 5/8 inches featuring 30 LED light bulbs. Carousel XL is 120cm / 47 1/4 inches and features 60 LED light bulbs. Both are suspended from a matching circular canopy by steel tensile wires.







CHAMBER

Housing a sculptural Carrara marble diffuser within a crystalline glass vessel, Chamber expresses the unexpected translucent qualities of marble in a compelling decorative pendant. With its gentle luminosity and directional downlight, Chamber is available in two sizes and lends itself to being hung in clusters as well as individually. Also available as a three piece chandelier and five piece chandelier with satin white canopy.





TUBE

Skillfully milled from a single piece of Carrara marble and finished at each end with bands of brushed brass or polished chrome, Tube contains a strip of LED light source resulting in what appears to be a solid length of warm glowing stone. The unique veins of each piece of marble means no two lights are exactly the same. A handcrafted twist on the traditional fluorescent tube light. Also available as a wall mounted light.



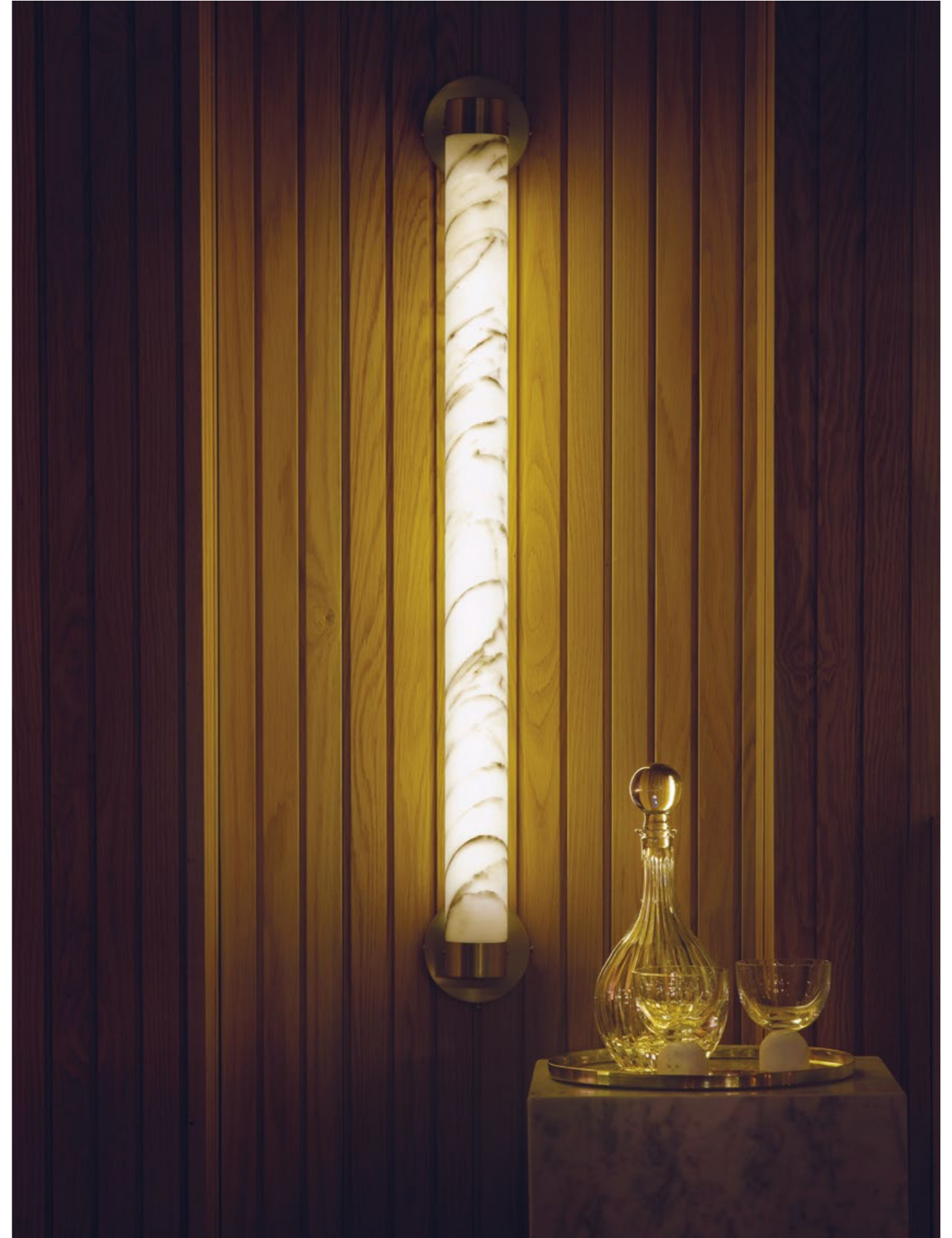

CRYSTAL TUBE

Composed of a decoratively patterned length of hand-cut glass capped at each end with brushed brass or polished chrome, Crystal Tube contains a slender LED light source resulting in a sparkling beam of light. A luxurious reimagining of the standard fluorescent tube light, Crystal Tube is suspended from both ends by a thin steel tensile wire allowing it to be hung horizontally. Also available as a wall mounted light.

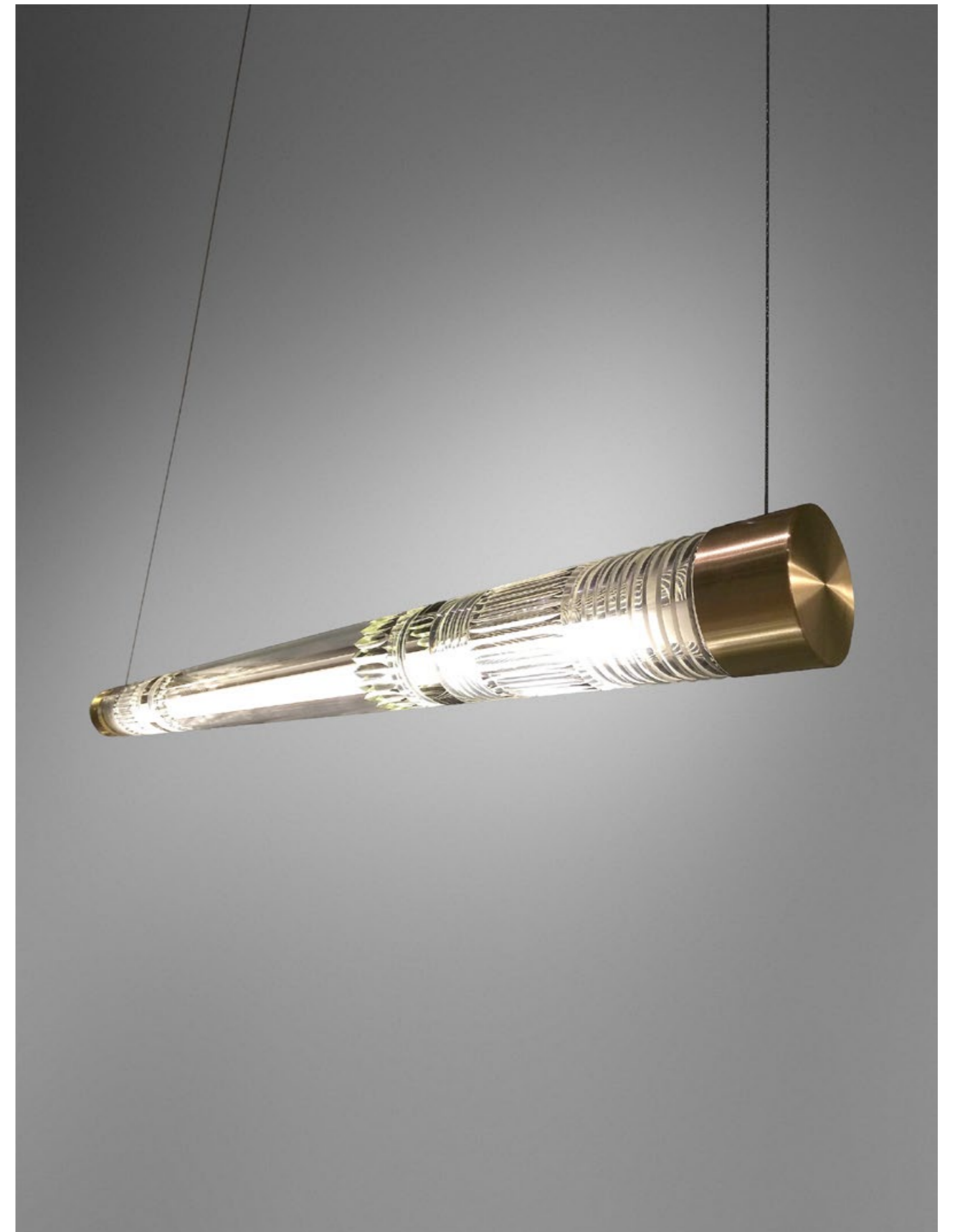

CRYSTAL BULB

Taking inspiration from the delicate craftsmanship of crystal cutting, Crystal Bulb combines industrial influences with decorative qualities, transforming the everyday light bulb into a beautiful ornamental light fitting. Each Crystal Bulb is handcrafted using traditional techniques and hand cut with a classic crystal pattern inspired by traditional whiskey glasses and decanters. Crystal Bulb is available in a Clear or Frosted finish and the collection includes a brushed brass or polished chrome pendant, polished gold table lamp, three piece chandelier and five piece chandelier. Crystal Bulb is also available as a brushed brass wall light and ceiling light. The Crystal Bulb features a warm white LED, which is replaceable.







DECANTERLIGHT

Crafted from hand cut crystal, Decanterlights are inspired by the vintage drinks decanters found in a traditional British drawing room. Referencing three classic decanter shapes, the Square, Bell and Tulip pendants produce a warm, welcoming glow and refracted light casts intricate shadows on surrounding surfaces. A five piece and three piece chandelier suspends a selected mix of shades at different heights to create a stunning lighting centerpiece.





ACID MARBLE

A layer of white Carrara marble and acid yellow tinted optical acrylic are sandwiched together to form an illuminated circular diffuser for the sculptural Acid Marble Table Lamp. Set into a solid Nero Marquina marble base, the veins of the Carrara marble are visible through the optical disc allowing the marble to appear yellow, giving this very classic material a playful twist.





FURNITURE

HANGING HOOP CHAIR

Suspended by a chain, two circular steel hoops join to create Hanging Hoop Chair, a modern swing chair with an iconic outline. The angled inner hoop supports a padded backrest that is perfectly aligned with the hemispherical seat, both of which are upholstered in Kvadrat wool. The frame is available in matte black and brushed brass plated finishes.



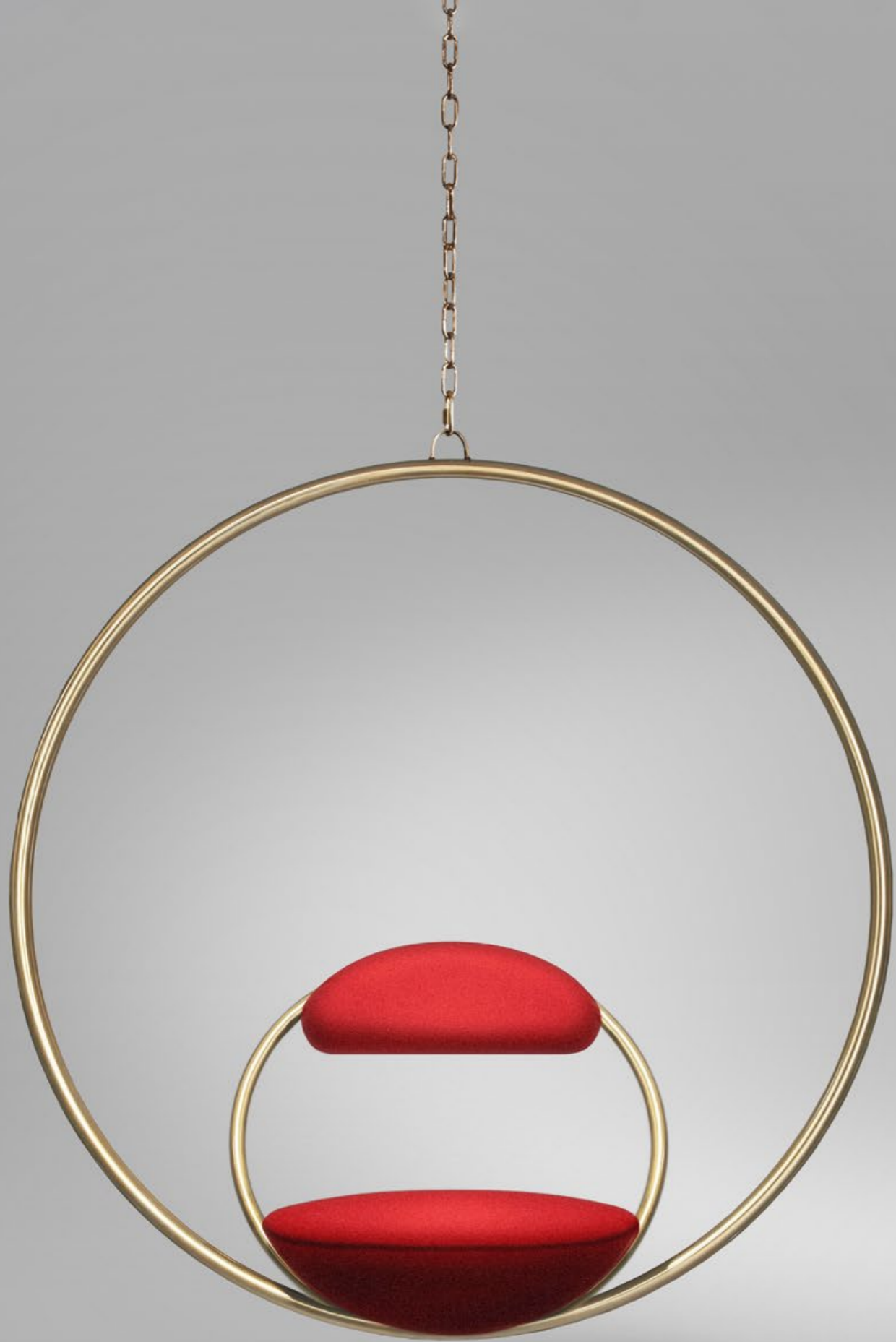

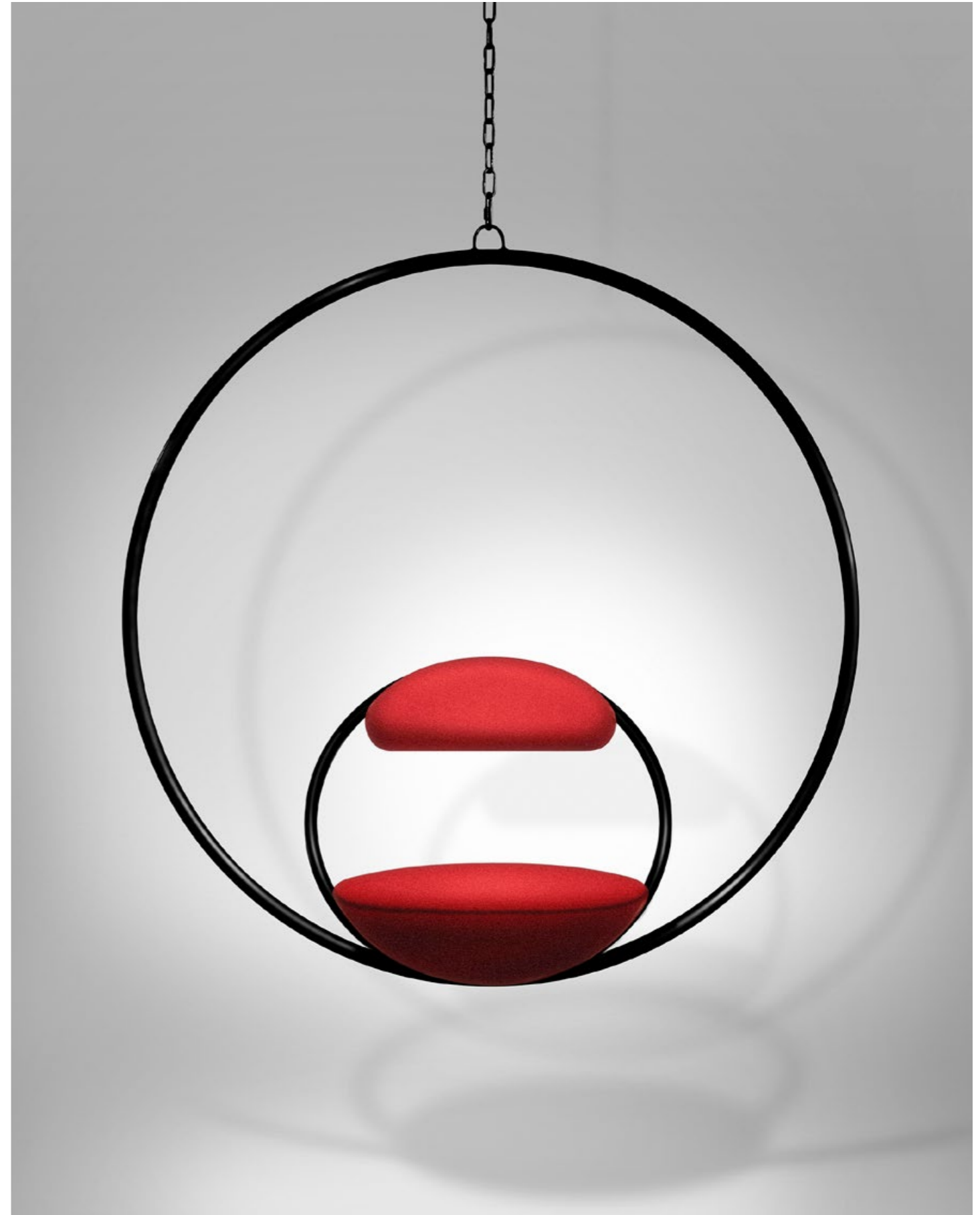

MUSICO CHAIR AND TABLE

The Musico Chair features an original silhouette inspired by Lee Broom's long-held passion for mid-century design and, perhaps more significantly, his great love of classical music, which plays an integral part in his design process. Reminiscent of the coils and wraps of musical instruments, its contours have been created by three continuous hand-bent, hand-polished and plated tubes, which form a seamless circular-like embrace around the chair's upholstered seat and back.

The Chair comes in three finishes including satin brass, polished chrome and matte black. A wide selection of fabrics are also available for upholstery including wool produced in the UK, leather and velvet. Customers own material can also be requested.

The Musico table, which takes its cues from the chair's design with a base formed from the same linear tubes. The Musico table features hand-bent, intricately twisted stainless steel tubes and a glass tabletop. It is available in polished chrome and a matte black finish with either a clear or tinted glass top.





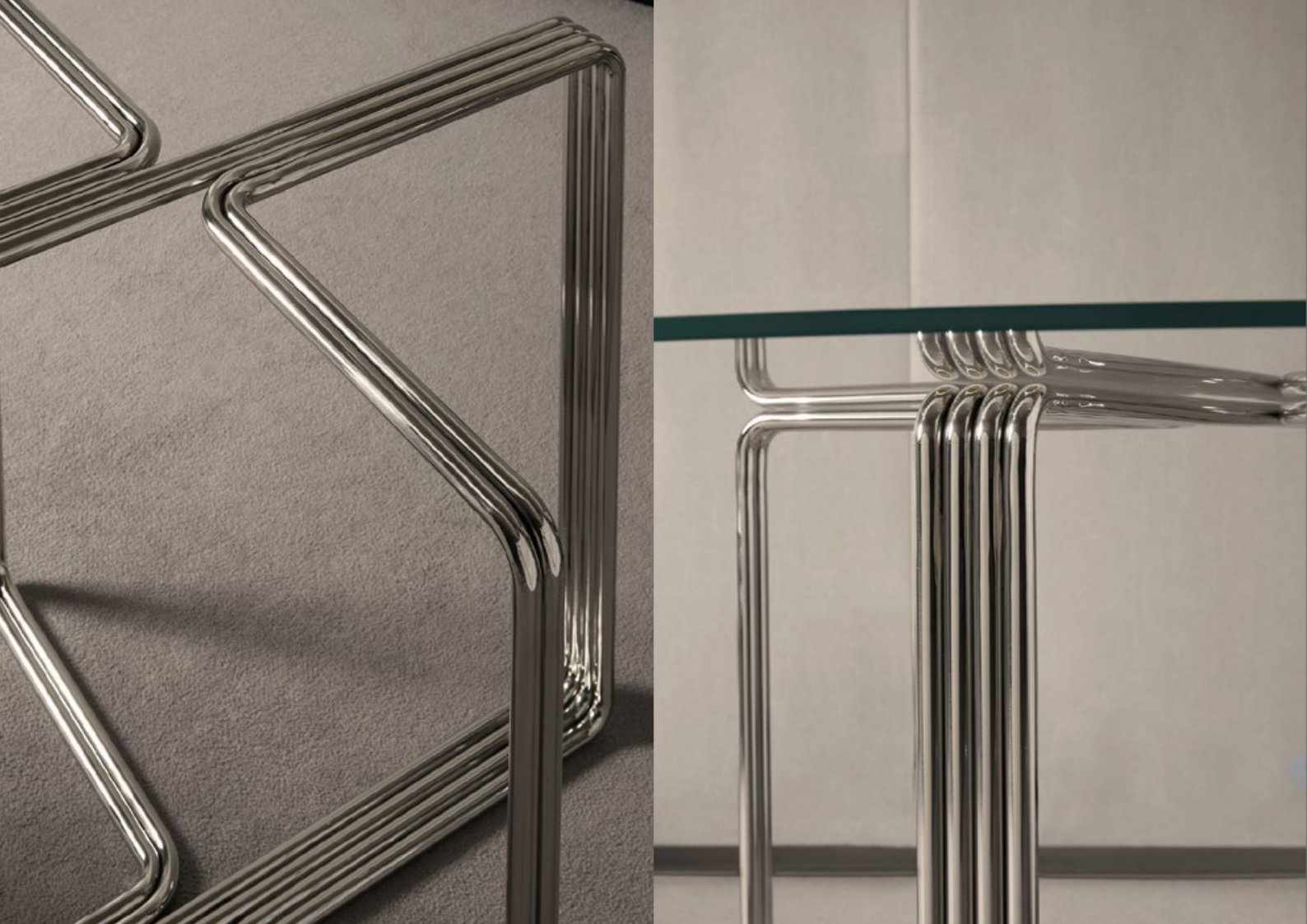

TRIBECA TABLES

The Tribeca Tables are a series of sculptural side and coffee tables, which appear to defy gravity. Crafted in black silk marble and travertine with a stepped detail that reflects the soaring local architecture, the smooth round table top cantilevers over a monolithic square base, balancing perfectly.





WHITE STREET SOFA

The White Street Sofa highlights Lee Broom's long-held fascination with symmetry and seamlessness. This architectural, streamlined, modular piece can be arranged in multiple configurations and is effortlessly connected by sculpted armrests, corner or side tables, each produced in black or white ash. Shown in a sumptuous ivory bouclé by Dedar, but available in multiple colours, the sofa, with its expansive and curved back, appears to float, anchored only by its connectors. The White Street sofa is available as a two seat, three seat and corner configuration sofa.







SHADOW CABINET

The Shadow Cabinet is a handmade contemporary piece playing with the concept of optical illusion with traditional crafted materials. A series of triangular facets run vertically down the front of the cabinet with one side in American walnut and the other in brushed brass. From one angle the Shadow pieces appear to be all wood and from the other all brass. Sitting under a solid piece of brushed brass, the cupboards of the Shadow Cabinet are cleverly disguised within the vertical geometry.



TIME MACHINE

Time Machine is an exclusive statuesque marble grandfather clock measuring 168.5cm / 66 3/4 inches high. Hand-crafted from Carrara marble, the monolithic and commanding structure features a traditional engineered clock mechanism with solid brass pendulum, weight and hands. Limited to an edition of 10.



SPLIT MIRROR

A precision cut mirror slice, shifted from its original position, reveals an oak trimmed section of the black frame on Split Mirror. This modern wall mirror has a distinct personality. Both the round and long variations of Split Mirror have been lacquered in a matte black finish to complement the oak trim.



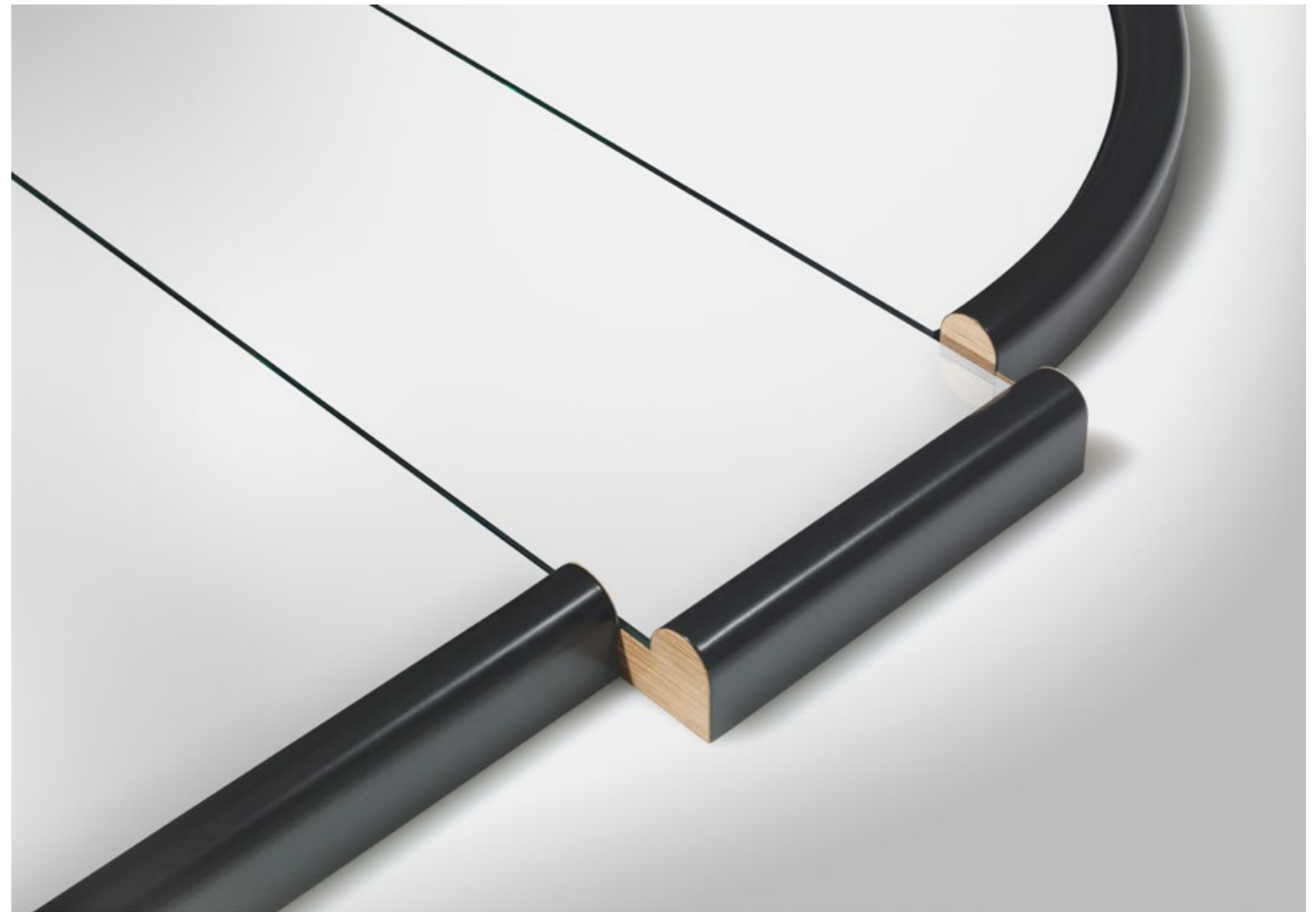
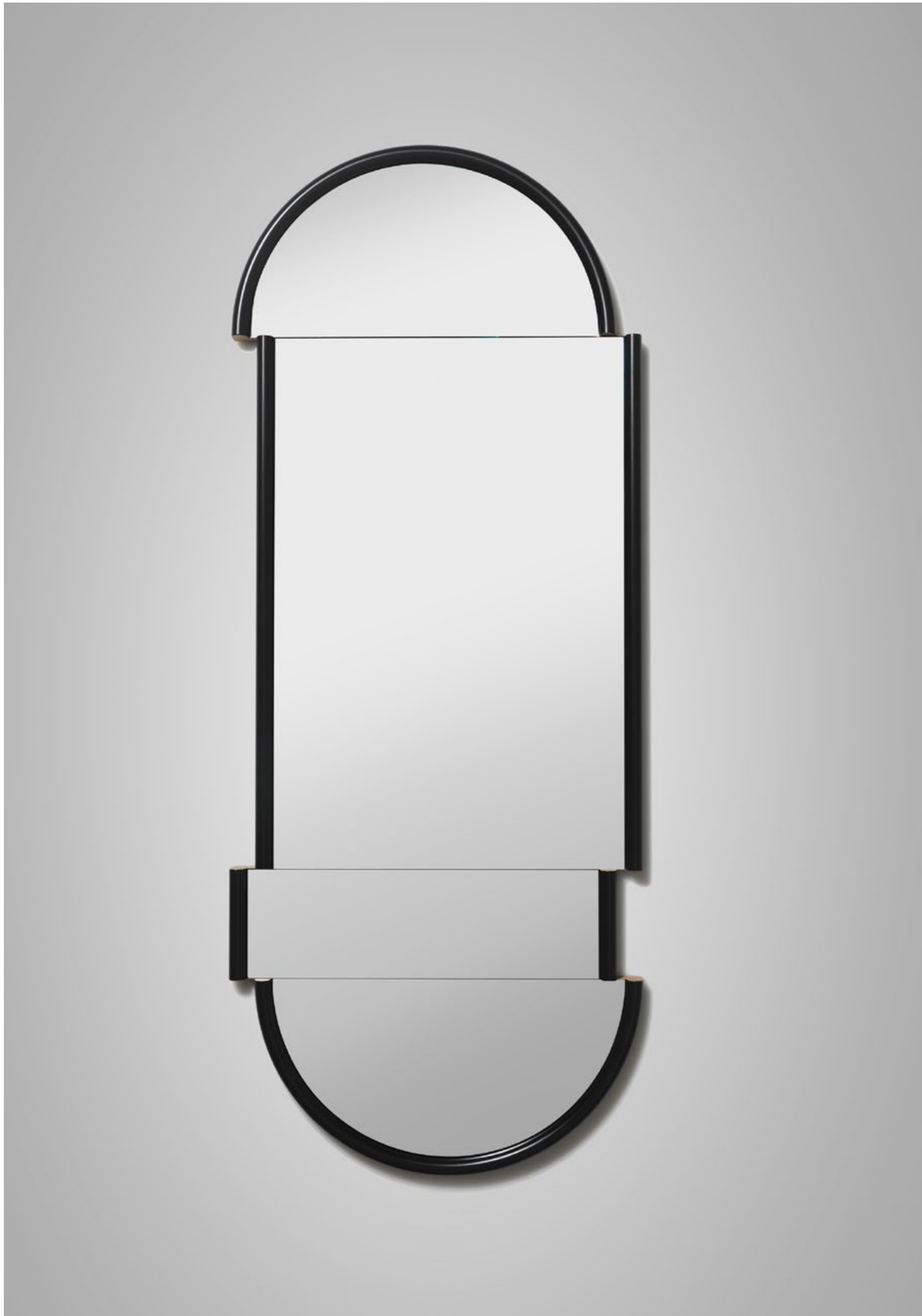



ACCESSORIES

LEE BROOM SCENTED CANDLE

The Lee Broom scented candle comprises of two separate elements that fit seamlessly together. An elegant cubist candle holder, hand-crafted in solid optical crystal and the metal vessel, finished in either polished gunmetal or gold which contains the candle itself. The candle glides smoothly into the crystal's interior to sit suspended perfectly within. Once the candle is finished, it can then be replaced with a new candle from the range.

Each candle is created using the highest-quality, biodegradable, 100% natural soy and an unbleached natural cotton wick, which has been hand-poured in the UK. The natural scents, which have been blended and developed with a French fragrance house, feature notes and scents that are personal to the designer.





ON REFLECTION

On Reflection, presented in the gold vessel, is an uplifting scent that offers a complex woody, citrus fragrance, layered with comforting iris, lavender, heart notes of precious woods and topped with mandarin and lime.





SELF PORTRAIT

Self Portrait, presented in the gunmetal vessel, is a rounded scent that brings a sense of calm and well-being with its diverse floral and musky notes of fresh linen, bergamot, melded with the familiar fruitiness of pear and violet and a warming base of amber.



WEDGWOOD BY LEE BROOM

A prestige capsule collection of limited edition hand-crafted Jasperware vases and bowls, the Wedgwood by Lee Broom collection is a true showcase of craftsmanship and design. With silhouettes and archetypal designs taken from Wedgwood's 250-year old archive, ornate detailing has been stripped back and the traditional Jasperware finish juxtaposed with postmodern elements to produce thoroughly cutting-edge versions of timeless classics limited to 15 editions of each of the four designs.



FULCRUM CANDLESTICK

Fulcrum is a sculptural and monolithic candlestick whose cylindrical stem appears to balance on a central sphere. Containing a large tea light, Fulcrum Candlestick is available in solid optical crystal, white Carrara marble or black Nero Marquina marble. The small Fulcrum candlestick is 31cm / 12 ¼ inches tall and the large size is 40cm / 15 ¾ inches.









PRODUCT DETAILS

PRODUCT DETAILS

VESPER

1. Vesper Duo, brushed gold / 2. Vesper Quattro, brushed silver

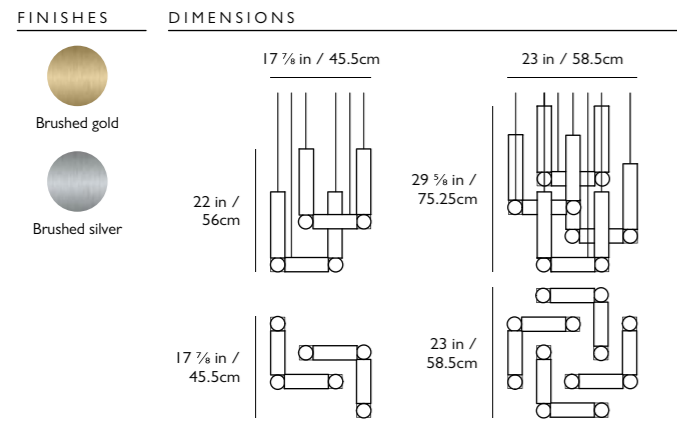

HAIL

1. Hail 3-piece Chandelier, brushed silver / 2. Hail 3-light Short, brushed gold / 3. Hail 6-light Tall, brushed silver / Hail 3-light Tall, brushed gold

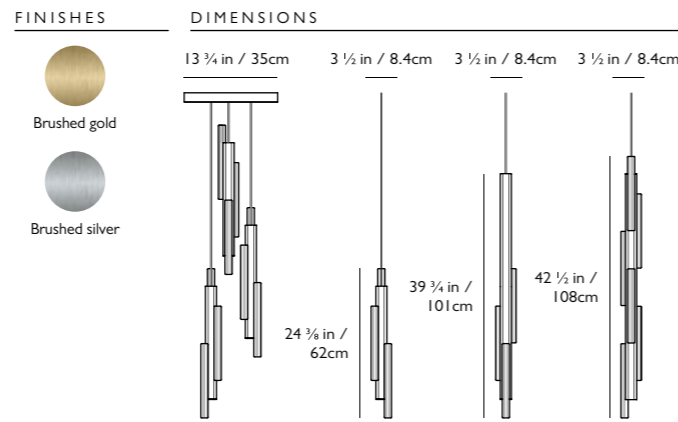

ALTAR

1. Altar 4-light Short / 2. Altar 4-light Tall / 3. Altar 8-light Tall

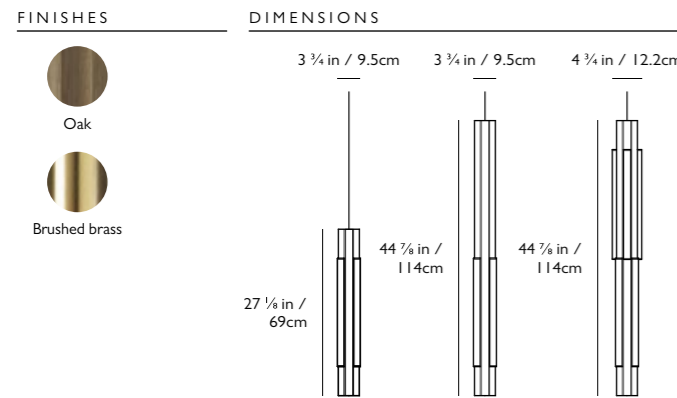

PANTHEUM

Pantheum Surface Light

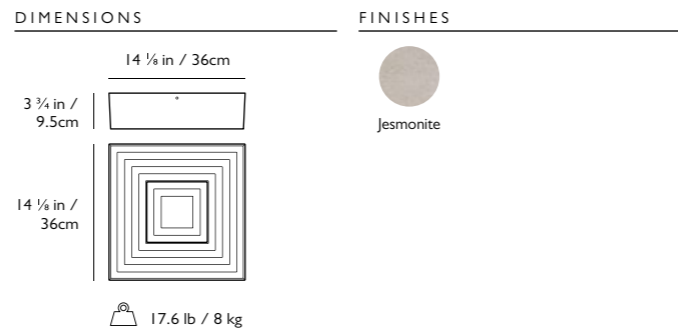

PRODUCT DETAILS

REQUIEM

1. Requiem Ring Light / 2. Requiem Globe Light



MATERIALS

Fabric, plaster and opal glass

INFORMATION

Sizes are approximate.

Limited edition.

Products made to order on application.

DIMENSIONS

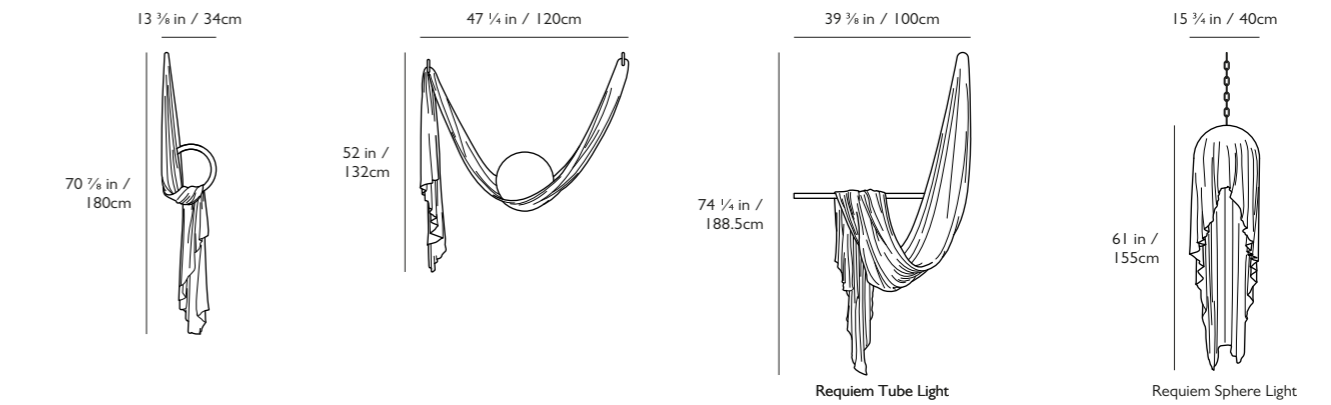

CHANT

1. Chant 4x4 Chandelier Frosted, brushed silver / 2. Chant 6x6 Chandelier Clear, brushed gold / 3. Chant 6x6 2-tier Chandelier Frosted, brushed silver



DIMENSIONS

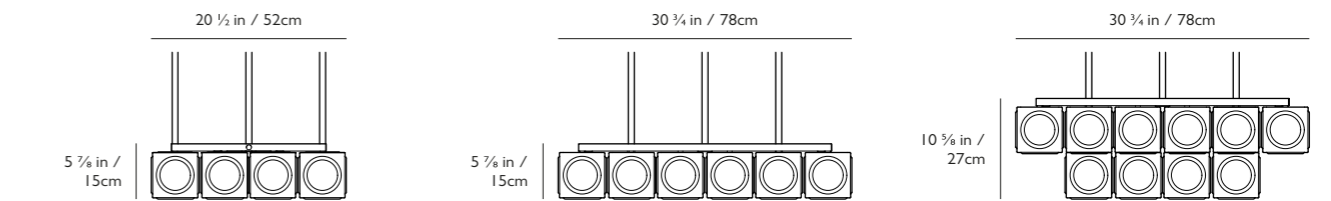

FINISHES



PRODUCT DETAILS

MINI CRESCENT

1. Mini Crescent Pendant Light / 2. Mini Crescent Ceiling Light / 3. Mini Crescent Table Lamp / 4. Mini Crescent Chandelier 5 Piece / 5. Mini Crescent Chandelier 3 Piece

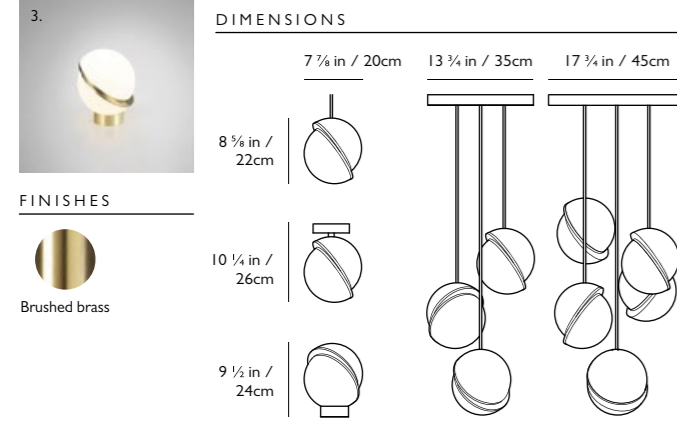

CRESCENT

1. Crescent Pendant Light / 2. Crescent Table Lamp

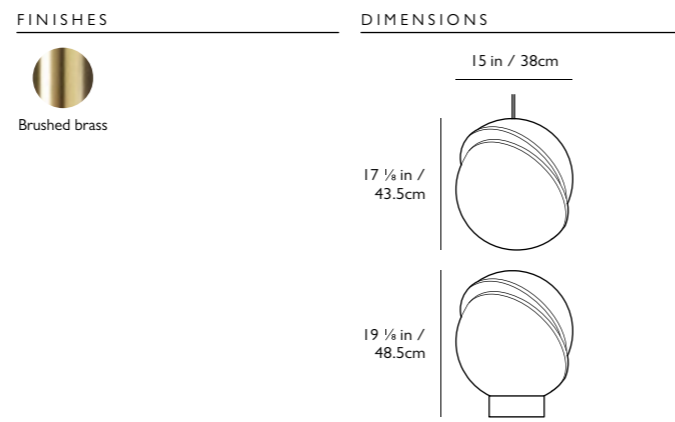

LENS FLAIR & LITTLE LENS FLAIR

1. Lens Flair Pendant Light, brushed brass / 2. Little Lens Flair Pendant Light, matte black / 3. Little Lens Flair Pendant Light, brushed brass / 4. Little Lens Flair Chandelier 3 Piece, matte black

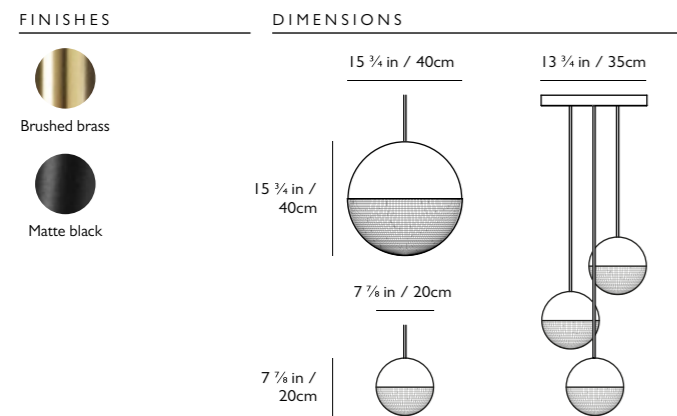

HANGING HOOP CHAIR

1. Hanging Hoop Chair, brushed brass / 2. Hanging Hoop Chair, matte black

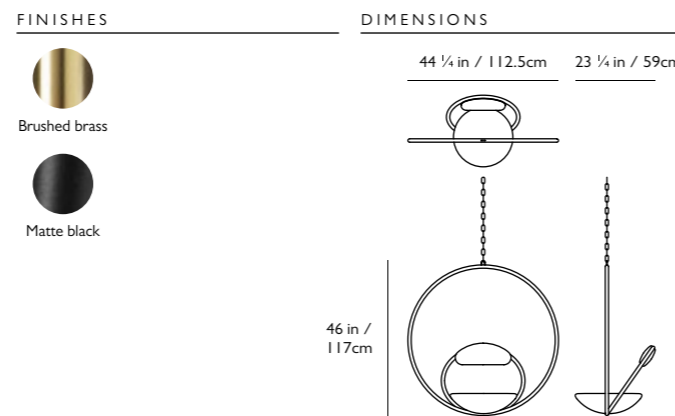
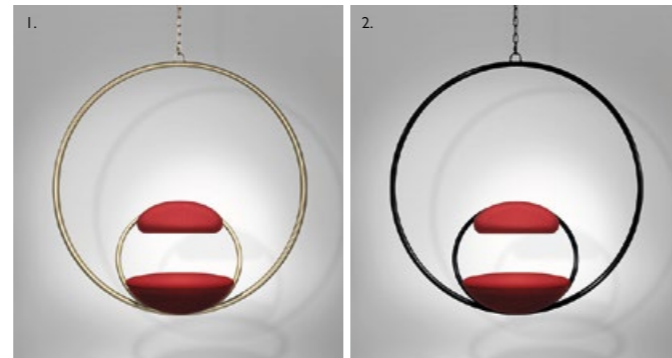

PRODUCT DETAILS

ORION

1. Orion Tube Light, polished gunmetal / 2. Orion Globe Light, polished gunmetal / 3. Orion Tube Light and Orion Globe Light cluster, polished gold

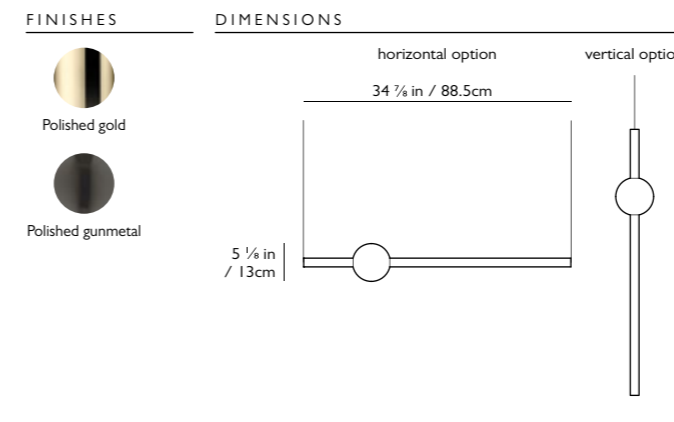
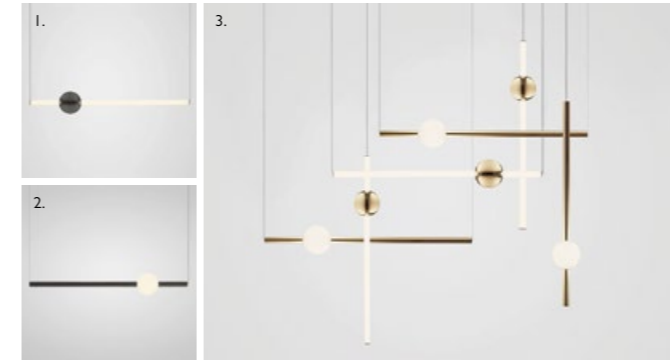

ECLIPSE

1. Eclipse Pendant Light, polished gold / 2. Eclipse Table Lamp, polished chrome / 3. Eclipse Chandelier, polished chrome / 4. Eclipse Chandelier, polished gold

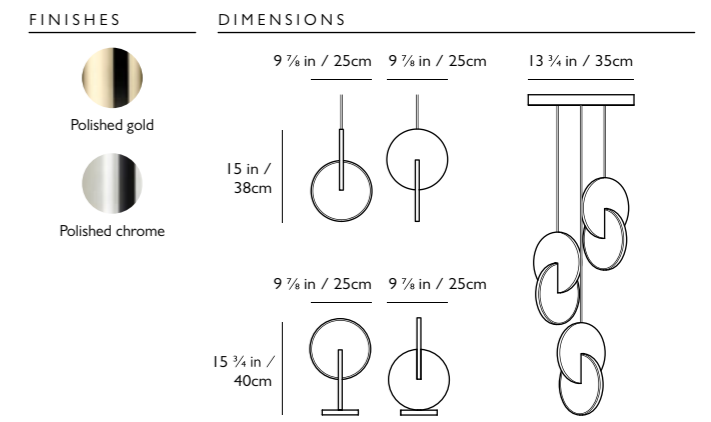

RING

Ring Light

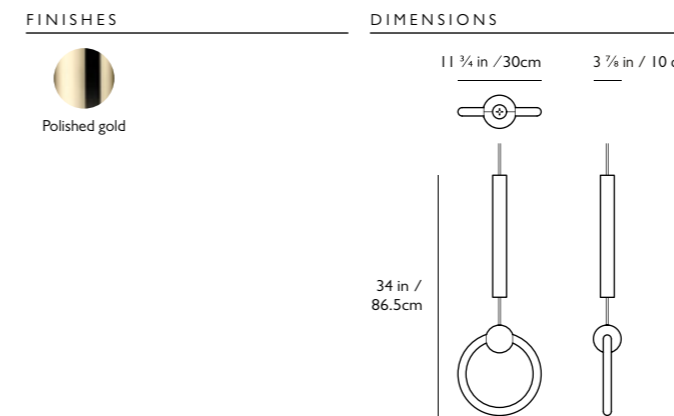

SHADOW

Shadow Cabinet

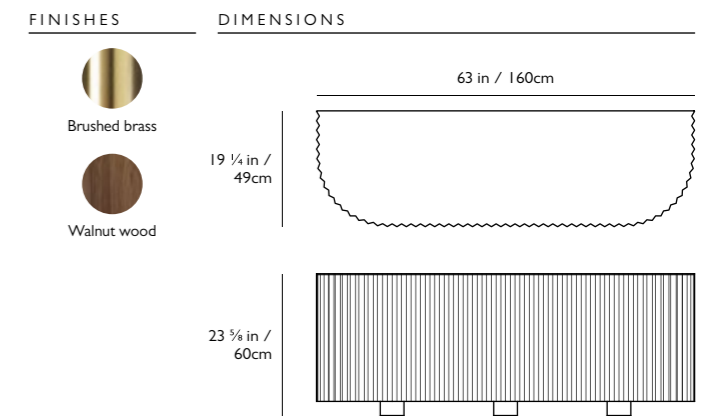

Product details may change. For latest information please visit www.leebrook.com

UK & Global Inquiries +44 207 820 0742 info@leebrook.com USA enquiries + 1 212 804 8477 sales@leebrook.com

Product details may change. For latest information please visit www.leebrook.com

UK & Global Inquiries +44 207 820 0742 info@leebrook.com USA enquiries + 1 212 804 8477 sales@leebrook.com

PRODUCT DETAILS

FULCRUM LIGHT

1. Fulcrum Light, polished gold / 2. Fulcrum Light, polished chrome / 3. Fulcrum Light, matte black / 4. Fulcrum Chandelier 3 Piece, matte black / 5. Fulcrum Chandelier 5 Piece, polished gold

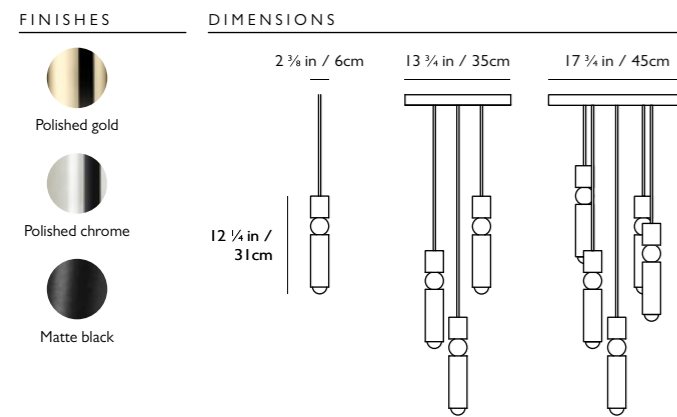

CAROUSEL & CAROUSEL XL

1. Carousel, polished gunmetal / 2. Carousel XL, polished chrome

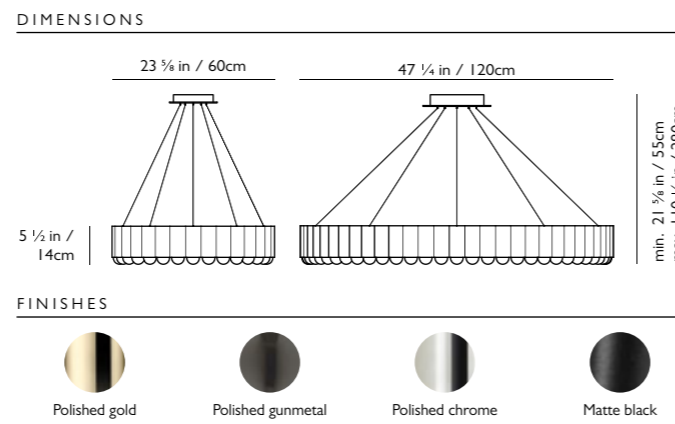
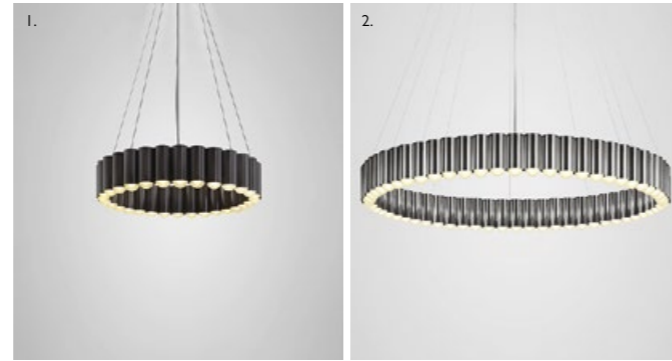

SPLIT MIRROR

1. Split Mirror Long / 2. Split Mirror Round

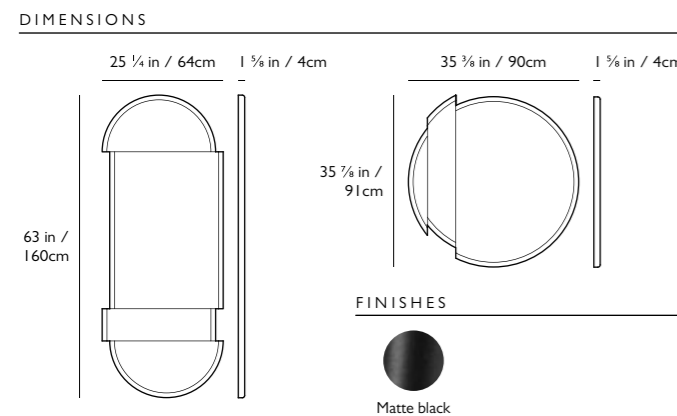
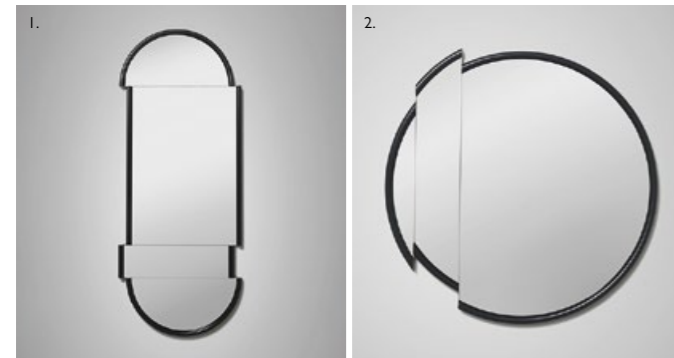

FULCRUM CANDLESTICK

1. Fulcrum Candlestick Small, clear / 2. Fulcrum Candlestick Large, black marble / 3. Fulcrum Candlestick Small & Large, white marble / 4. Fulcrum Candlestick Small & Large, travertine

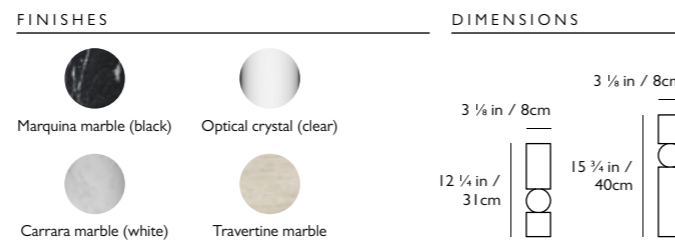

PRODUCT DETAILS

CRYSTAL BULB

1. Frosted Crystal Bulb Pendant, polished chrome / 2. Frosted Crystal Bulb Ceiling Light / 3. Clear Crystal Bulb Ceiling Light / 4. Frosted Crystal Bulb Chandelier 3 Piece, brushed brass / 5. Clear Crystal Bulb Chandelier 5 Piece, polished chrome

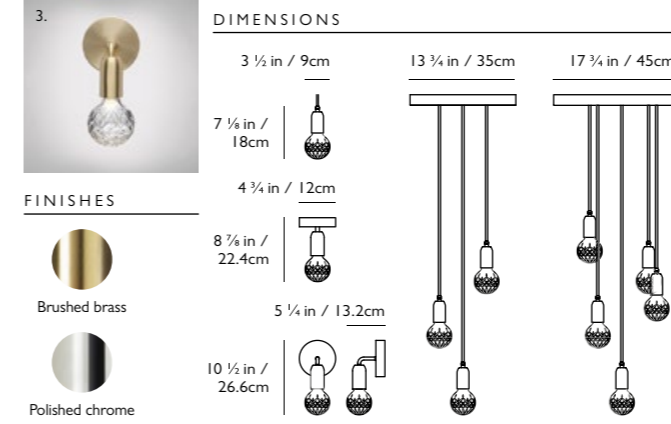

DECANTERLIGHT

1. Decanterlight Tulip / 2. Decanterlight Square / 3. Decanterlight Bell / 4. Decanterlight Chandelier 3 Piece / 5. Decanterlight Chandelier 5 Piece

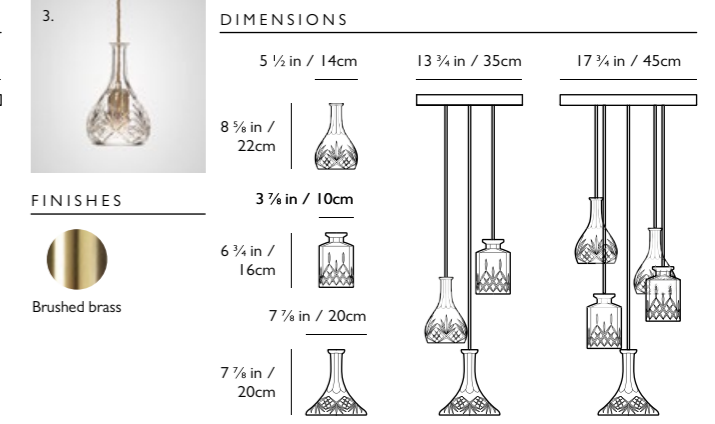

SCENTED CANDLE

1. On Reflection Scented Candle, polished gold / 2. Self Portrait Scented Candle, polished gunmetal

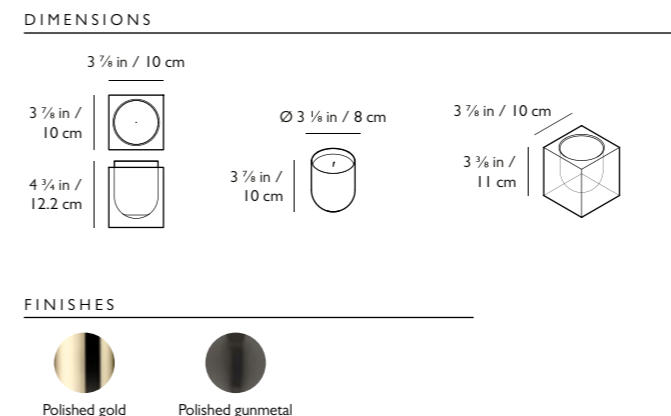

WEDGEWOOD

1. Wedgwood Bowl On Red Sphere / 2. Wedgwood Vase On Blue Rectangle / 3. Wedgwood Ornamental Vase On Yellow Sphere / 4. Wedgwood Vase On Orange Sphere

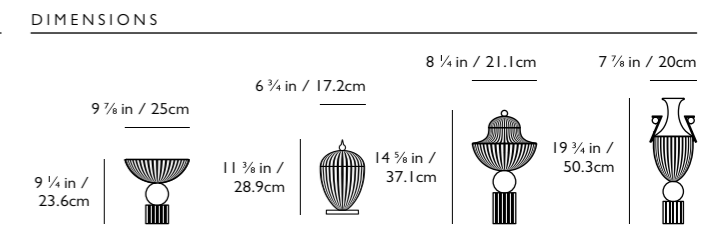

Product details may change. For latest information please visit www.leebrook.com

UK & Global Inquiries +44 207 820 0742 info@leebrook.com USA enquiries + 1 212 804 8477 sales@leebrook.com

Product details may change. For latest information please visit www.leebrook.com

UK & Global Inquiries +44 207 820 0742 info@leebrook.com USA enquiries + 1 212 804 8477 sales@leebrook.com

PRODUCT DETAILS

CHAMBER

1. Chamber Light Small / 2. Chamber Light Large / 3. Chamber Chandelier 3 Piece / 4. Chamber Chandelier 5 Piece



DIMENSIONS

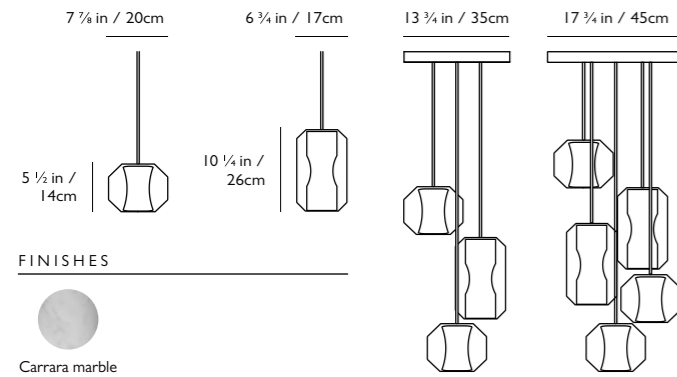

FINISHES



AURORA

1. Aurora Ring 1 / 2. Aurora Ring 2 / 3. Aurora 3 Tier Chandelier, 1x Ring 4 & 2x Ring 3 / 4. Aurora 2 Tier Chandelier, 1x Ring 5 & 1x Ring 4



DIMENSIONS

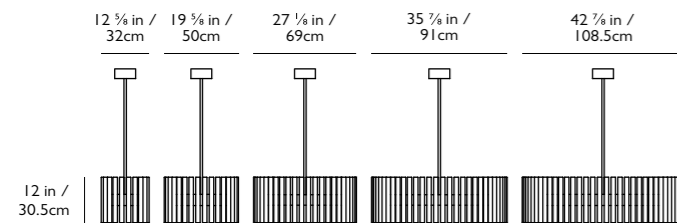

FINISHES



TUBE & CRYSTAL TUBE

1. Tube Wall Light, polished chrome / 2. Crystal Tube Light, brushed brass

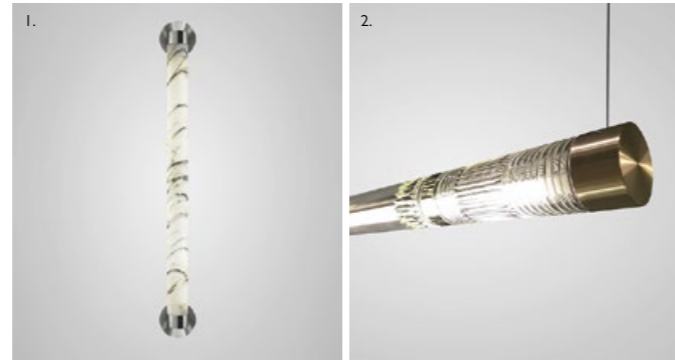

FINISHES

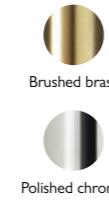

DIMENSIONS

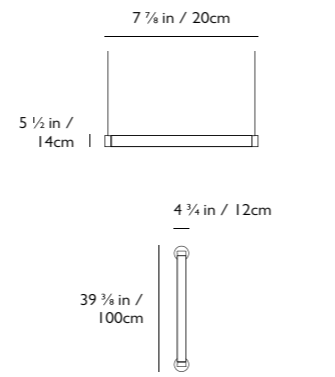

ACID MARBLE

Acid Marble Table Lamp



DIMENSIONS

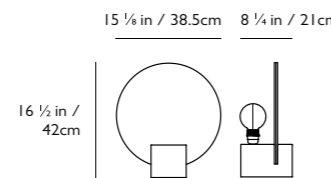

FINISHES



TIME MACHINE

Time Machine Grandfather Clock



DIMENSIONS

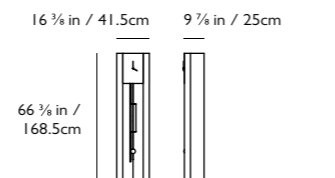

FINISHES



PRODUCT DETAILS

MUSICO CHAIR

1. Musico Chair, satin brass / 2. Musico Chair, matte black / 3. Musico Chair, polished chrome



FINISHES

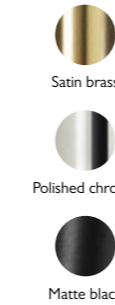

DIMENSIONS

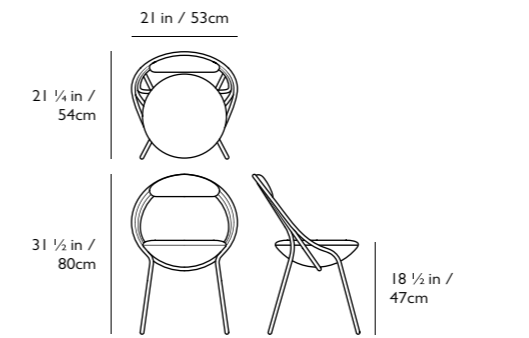

MUSICO TABLE

Musico Table, polished chrome with clear glass top



FINISHES

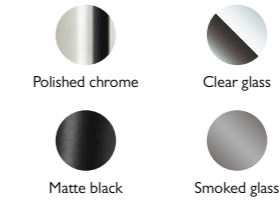

DIMENSIONS

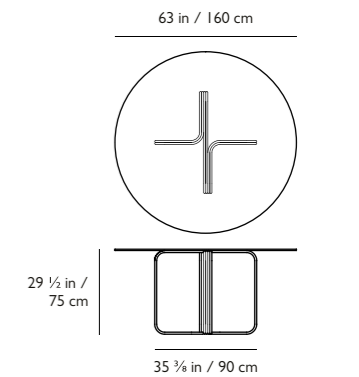

WHITE STREET SOFA

White Street corner configuration sofa (2x 3 Seater Sofa in Ivory Boucdé + 1x Corner Table in White Ash + 1x Cantilever Side Table in White Ash + 1x Side Table in White Ash).



DIMENSIONS

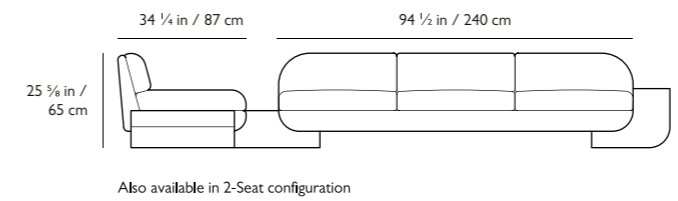

FINISHES



TRIBECA TABLES

1. Tribeca Table Wide / 2. Tribeca Table Tall



FINISHES



DIMENSIONS

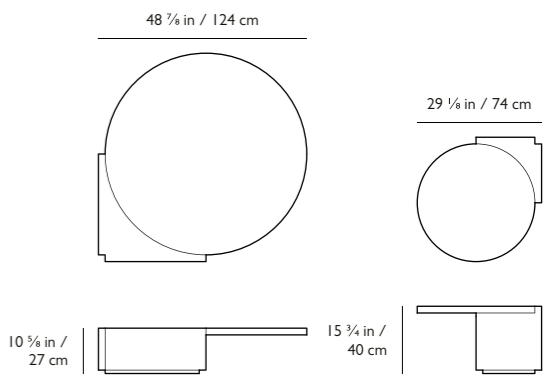



LONDON SHOWROOM

95 Rivington Street, London, EC2A 3AY

Tel: +44 (0)207 820 0742

info@leebroom.com

NEW YORK SHOWROOM

New Showroom Opening Soon

Tel: +1 212 804 8477

sales@leebroom.com

[@leebroom](#)

www.leebroom.com